



Mech-Eye DEEP

DATASHEET



Mech-Eye DEEP



With a **working distance of 1,200 mm - 3,500 mm** and a **VDI/VDE accuracy of 3.0 mm**, the DEEP camera is especially suitable in scenarios that require a large field of view.

Specifications

Combining fast acquisition time, large field of view and high working distance, the DEEP is ideally suited for logistics applications such as palletizing & depalletizing.

Scope of delivery

DEEP Camera

Power - M12, 4-pin, A-coded to EU 230 (6 m) *

Data - M12, 8-pin, A-coded to RJ45 (10 m) *

*further cable lengths are available

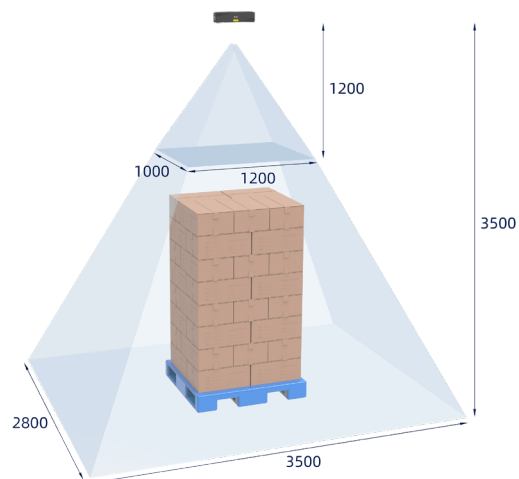

Technical drawing

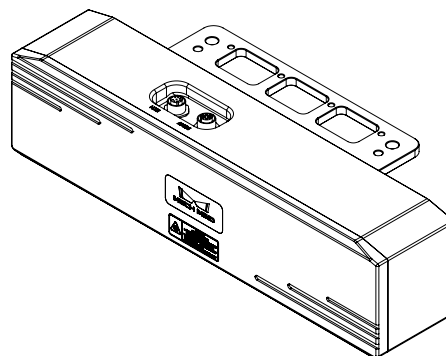
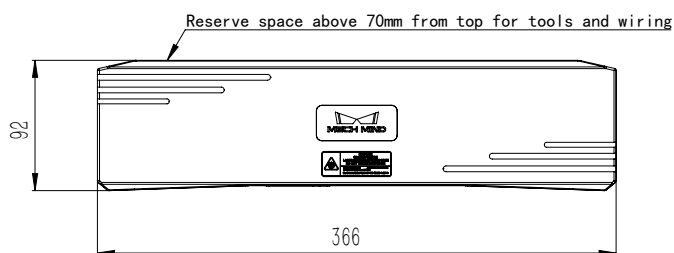

Technical data

Optimal scanning range	1,200 - 3,500 mm
Min. FOV	1,200 x 1,000 mm @ 1.2 m
Max. FOV	3,500 x 2,800 mm @ 3.5 m
Resolution	Depth 2,048 x 1,536 px (3.0 MP) RGB 2,000 x 1,500 px (3.0 MP)
Sensor type	CMOS (RGB)
Projector	Structured laser light (Class 2)
Z Repeatability	1 mm @ 3 m
VDI/VDE* accuracy	3 mm @ 3 m
Typical capture time	0.5 - 0.9 s
Baseline	300 mm
Dimension	366 x 77 x 92 mm
Weight	2.4 kg
Working temperature	-10 - 45 °C (max. gradient 10°/hour)
Interface	GigE, C++, C#, Python, ROS
Connectors	M12, 8-pin, A-coded (F) - Data M12, 4-pin, A-coded (F) - Power
Power supply	24V DC / 3.75 A
Certification	CE/FCC/VCCI/KC/UKCA
Protection class	IP65
Cooling	Passive

* Referring to VDI/VDE 2643 Part II



 www.mech-mind.de

 info@mech-mind.de