



CS625 | 6-axis Collaborative Robot

CS SERIES

 **25kg**
Payload

 **1500mm**
Radius

 **±0.08mm**
Repeatability

 **3.3m/s**
Max TCP Speed



CS625

CS SERIES



Robotic Arm

Payload	25kg
Radius	1500mm
Repeatability	±0.08mm
Axis	6
Joints rotation	J1-J6 ±360°
Joints speed	J1-J2 125°/s
	J3 150°/s
	J4-J6 210°/s
Max TCP Speed	3.3m/s
IP rating	IP68
Temperature range	0-50 °C
Relative humidity	<90% (non-condensing)
Typical power usage	625w
Mounting	Any angle
Tool I/O connector	T1: M8, 8pin; T2: Ø 12.8mm, 4pin
Tool I/O ports	4 config. DI, 4 config. DO; 1 AI, 1 AO
Tool I/O power supply	T1: 12V / 24V, 3A, 2A, 1A; T2: 24 V, 5A
Tool I/O communication	RS485, CAN
Footprint	Ø240mm
Weight	58kg
Material	Aluminum, Steel
Cable length	5.5m
Certifications	CE-EMC, CE-MD, ISO-13849, NRTL

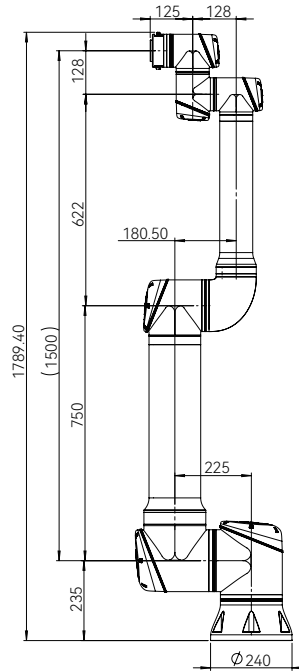

CS625 external dimensional drawing

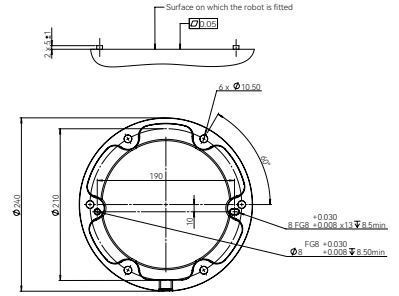

CS625 base top view

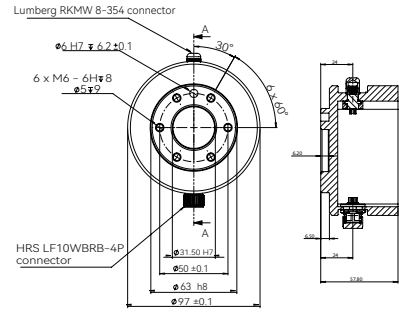

CS625 end flange

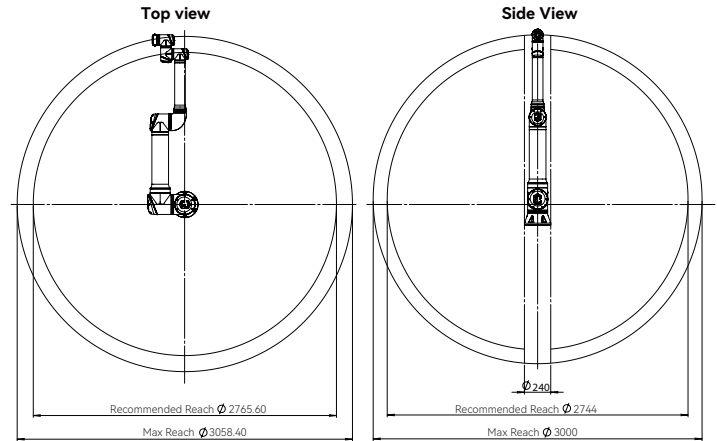

CS625 working range diagram

Teach-Pendant



Size	301mm x 232mm x 54mm
Material	Aluminum, Plastic
IP rating	IP54
Resolution	1280 x 800 pixels
Weight	1.7 kg
Cable length	5.5 m
Temperature range	0-50 °C
Input method	Capacitive touch-screen

Controller

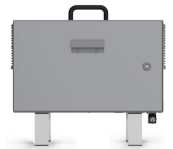

Size	505mm x 432mm x 257mm
Material	Aluminum, Steel
IP rating	IP44
I/O ports	24 x DI (8 config.), 24 DO (8 config.); 2 x AI, 2 x AO, 4 x High Speed DI
I/O power supply	24V; 3A (internal), 6A (external)
Communication	3 Ethernet, 1 RS485, TCP/IP, MODBUS TCP/RTU, EtherNet/IP slave, Profinet slave
Temperature range	0-50 °C
Power source	100-240 VAC, 50-60 Hz / 19-72VDC

The controller is also available in an OEM version.