

EN GARLINE 30

Laser seam tracking welding sensor (laser profilometer)

QUICKSTART



Components identification

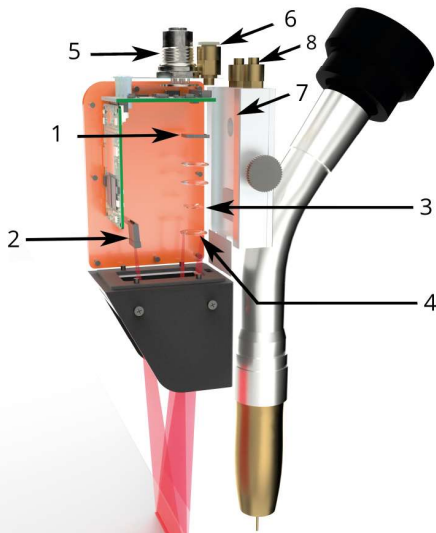

- 1. Camera sensor
- 2. Laser line generator
- 3. Optics filter
- 4. Custom designed optics
- 5. Power & Data connector
- 6. Air connector
- 7. Mounting plate
- 8. Water cooling connector

LED indicators



- 9. Ethernet | 10. Status | 11. Laser

Measuring field (mm)

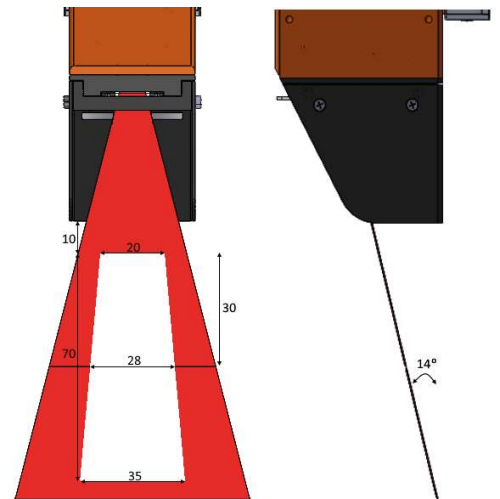

Connection diagram

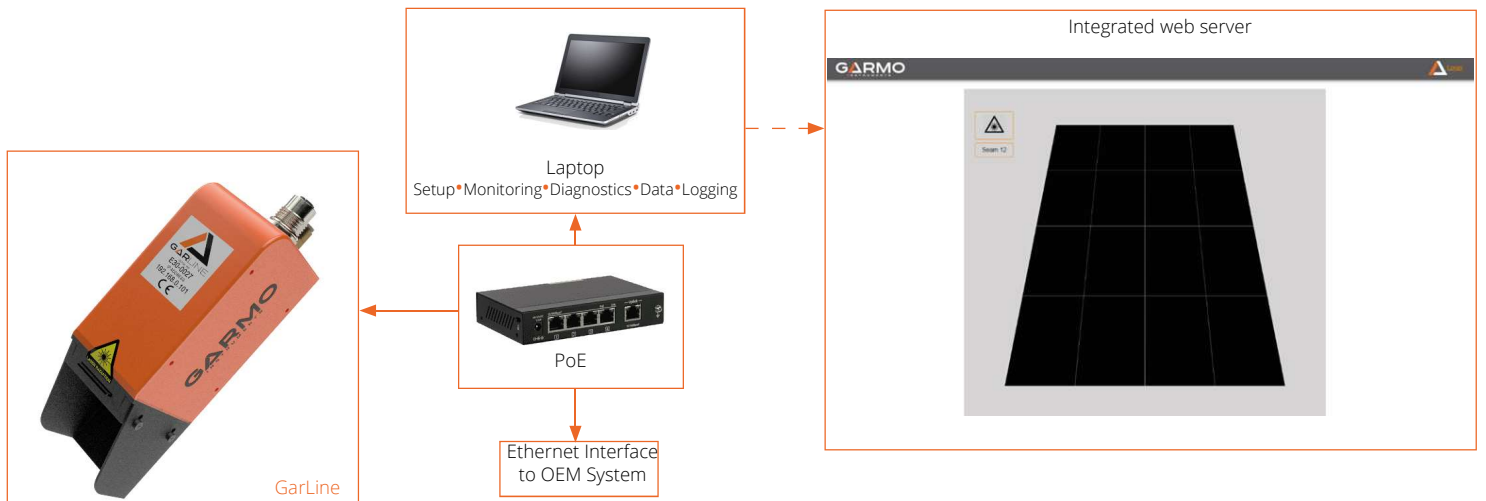

Measurements (in mm)

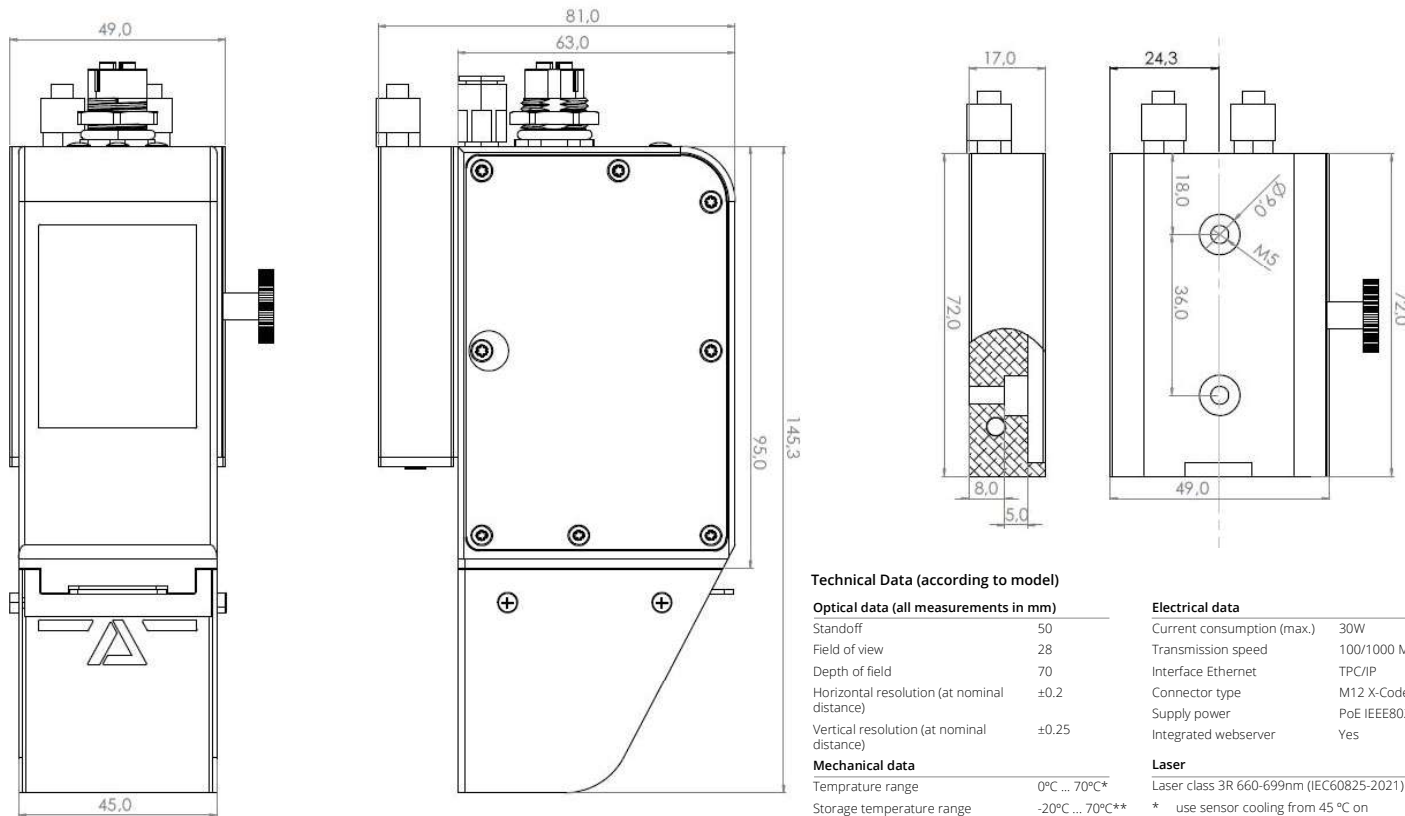

Technical Data (according to model)

Optical data (all measurements in mm)

Standoff	50
Field of view	28
Depth of field	70
Horizontal resolution (at nominal distance)	±0.2
Vertical resolution (at nominal distance)	±0.25

Mechanical data

Temperature range	0°C ... 70°C*
Storage temperature range	-20°C ... 70°C**
Measuring rate	42Fps
Protection	IP67***
Housing material	Aluminium
Disposable protective windows	Polycarbonate
Weight	450 g

Electrical data

Current consumption (max.)	30W
Transmission speed	100/1000 Mbit/s
Interface Ethernet	TPC/IP
Connector type	M12 X-Code
Supply power	PoE IEEE802.3at
Integrated webserver	Yes

Laser

Laser class 3R 660-699nm (IEC60825-2021)

* use sensor cooling from 45 °C on
 ** non-condensing
 *** only when the cable is connected



Information Concerning these Instructions

- These instructions apply to the product with ID code GarLine 30.
- In the event of possible changes, the respectively current version can be requested by sending an email to info@garmo-instruments.com.
- Instructions make it possible to use the product safely and efficiently.
- These instructions, along with the user manual, are an integral part of the product and must be kept on hand for the entire duration of its serviceable life.
- Read the operating instructions carefully before using the product.
- Local accident prevention regulations and national work safety regulations must be complied with as well.

Use for Intended Purpose

GarLine is a laser profilometer sensor for seam tracking and it is intended to be used in specialized welding machines or welding robots only.

The sensor is considered part of an equipment — it is intended to complement a robot or a specialized machine, so it would not be contemplated as one single component. Hence, there is no option for the sensor to perform on its own.

GarLine sensor is based on triangulation principle: it uses a structured light source (generated by a laser diode) in conjunction with an imaging device to produce a series of 2D slices through the weld joint and combine these slices to generate them into a 3D information.

The sensor projects a laser stripe across the weld joint. The stripe is then deformed by the shape of the joint. An optical filter, incorporated within the sensor, perceives only the light, which is at the same wavelength as the laser, projecting it into the 2D camera (the filter cleanses any light except for the one projected by the laser). Once the sensor perceives the seam shape, the internal electric circuit processes the image and spots the welding key points.

GarLine's electronics enables the adaptation of the parameters of laser power and camera gain, to adapt to the color variations of the materials. Since these electronics are incorporated within the sensor, the adaptation between frames is made at 42 images per second speed.

GarLine's connection system supports most of TCP/IP protocols and features a web interface, eliminating the need for a specific software. Wide seams selection performable by the sensor

is available on the sensor's web interface. GarLine's single PoE port on the rear part of the sensor head ensures an easy setup and integration. Only a PoE switch and a standard Cat6e cable are required.

Alternatively, Garmo Instruments could offer sample codes for general application.

General Safety Precautions

- The use of laser sensor, in conditions NON FORESEENED and/or PROHIBITED by these instructions, can lead to serious dangers for the worker, people and things around the equipment, and for the equipment itself.
- Maintain the safety regulations during the operation of the sensor: use the sensor correctly according to the established in terms of safety. Maintain the required safety and hygiene levels.
- Since the sensor includes 3R class laser within, it is not potentially dangerous for user's eyesight. Although, all safety measurements and instructions must be properly followed.

Laser Warning

Laser class 3R 660-699nm (IEC60825-2021): Applicable standards and safety regulations must be observed. The accompanying laser warnings must be attached in a clearly legible manner.

Before Installation

- Observe electrical and mechanical regulations, standards, and safety rules.
- Make sure that the sensor is mounted in a mechanically secure position and properly knobbed and fixed on the mounting plate.
- Make sure the protective polycarbonate window is properly fitted in before starting to weld.
- It is advisable that the sensor has an air supply during welding by providing a continuous air flow (5-10 liters/minute). Ensure that clean, dry and oil free air is supplied.
- Where less cooling is required, supply cold water through the water-cooled mounting plate.

Installation

1. GarLine should be installed such that the laser line is exactly perpendicular to the surface to be measured in order to obtain accurate measurement results.
2. Place the sensor head on the mounting plate.
3. Tighten the locking nut finger tight (to ensure that the retaining bolt does not come loose and to avoid any tracking errors, especially when sensor is mounted on robot).

4. Connect the sensor cable (and the air flow cable if necessary).
5. The sensor head can be powered on by connecting the cable to PoE injector. However, a calibration may be required. The mount provides a very repeatable mounting position for the sensor head, to minimize any setup required if the sensor is replaced.
6. Configure the target system.
7. Place the sensor towards the joint (having it in the field of view) to configure the seam via web interface.

Disassembling

1. Turn the power off by disconnecting the cable from PoE injector.
2. Remove the single connector from the sensor head (in case air flow cable is connected, remove it too).
3. Loosen the locking nut at the top of the mounting plate and then unscrew the knurled bolt until the sensor is free.
4. Lift the sensor off.

Electrical Connection

There is one PoE connector on the sensor, serving both power and data. The sensor is supplied with 30W operating power. Use a standard Cat6e cable to connect the sensor to the PoE switch.

The control unit and all signal cables are screened, what ensures protection from RF noise produced in an industrial environment (the grounding of the cable is necessary). The sensor cables should not be wrapped around high voltage cables and should wherever possible be separately routed.

In the unlikely event that the system is affected by electrical noise, ensure that the sensor head is electrically isolated from the machinery (e.g.: by using the insulation mounting plate).

Webserver Functions Description

GarLine's IP address can be found on the sensor head. All the seams and welding settings can be configured via web interface.

Complete operating instructions with a full description of sensor's configuration are available in the user manual.

Maintenance Instructions

GarLine is designed to keep the maintenance required to a minimum. However, to ensure good performance and a longer lifespan, periodic preventive maintenance checks are required

(for more details, check the maintenance section in the user manual).

GarLine sensor contains no user serviceable parts. In case any support or repairation is required, get in touch with Garmo Instruments' staff.

- GarLine sensor is maintenance-free.
- Cleaning lens covers at regular intervals is recommended in order to assure uniform good quality of the measured values (e.g.: a soft cloth for cleaning eyeglasses can be used for this purpose).
- Do not clean the sensor with solvents or cleansers which could damage it.
- If the disposable protective window is damaged or dirty, replace it with a new one.
- For advanced maintenance:
 - Clean any excess of dust or splatter from the outside of the sensor with an alcohol moistened cloth or compressed air.
 - In case of cooling the sensor through air flow connector, you may use a vortex tube.
 - Check all the cables' status (if they're kinked or twisted, replace them).

Liability Disclaimer

The manufacturer, Garmo Instruments, S.L., does not take responsibility for equipment failure or damage caused by it, in cases where its handling or maintenance does not correspond to the indications in this technical datasheet or user's manual, as well as in cases where the sensor has been used for different purposes of those for which it has been designed.

The user is not allowed to carry out unauthorized technical research on any aspects of the equipment. Any attempt by the user or unauthorized personnel to disassemble or modify the equipment without previous authorization from Garmo Instruments, S.L. will exempt the manufacturer from all responsibility for eventual damage to people, things or other affected goods.

CONTACT

Garmo Instruments, S.L.
 Pol. Industrial Malpica, Calle E, 32-39, Nave 43
 50016 • Zaragoza • SPAIN
 Phone: (+34) 876 063 254
 E-mail: info@garmo-instruments.com
 www.garmo-instruments.com