

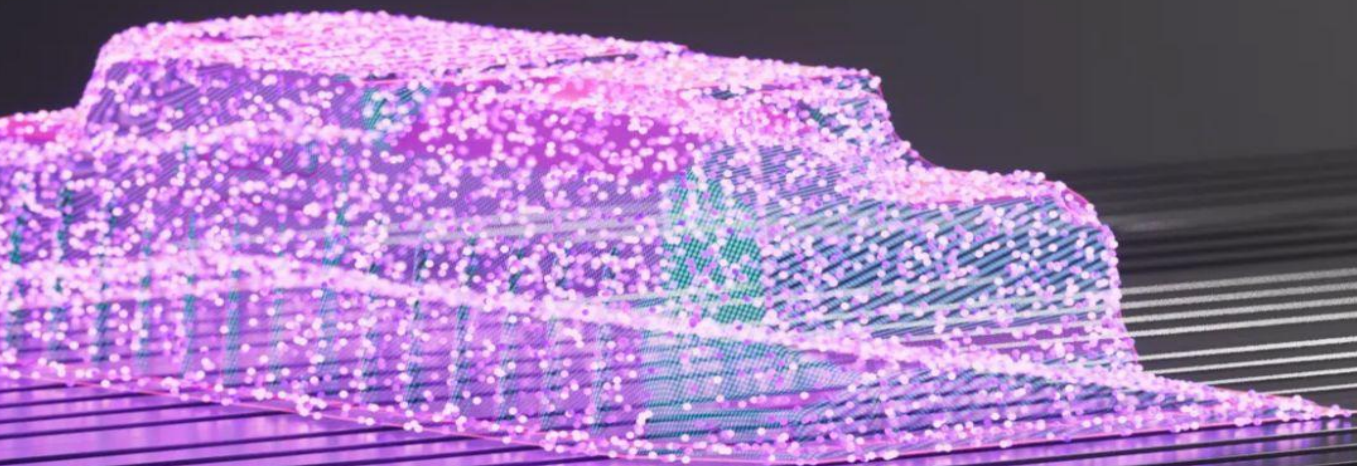

inbolt



GuideNOW
Technical Specifications
June 2023



Revision history	3
I. Introduction	4
A. GuideNOW	4
B. Components	4
C. Communication and interface	4
II. Features, benefits and uses cases	5
A. Features	5
B. Benefits	6
C. Use cases	7
III. Configuration	7
A. Robot compatibility	7
B. Basic runtime communication diagram	8
C. Hardware Setup	8
D. GuideNOW Studio - Web application	8
IV. Specifications	9
A. Inbrain performance	9
B. Inbrain detailed performance	9
1. Time performance	10
2. Catch up time (for moving parts only)	10
3. Dynamic precision (for moving parts only)	11
4. Detection performance	12
C. Warnings	12

Revision history

Revision number	Description	Révision date
001	Pre-release	November 2022
002	Release	February 2023
003	Update industrial version	May 2023

I. Introduction

A. GuideNOW

GuideNOW is a real-time robot guidance solution based on 3D vision.

It comprises a 3D camera mounted on the robot, Inbrain, our real-time workpiece localization AI: Inbrain, and GuideNOW Studio, a web-app for Inbrain training.

Inbrain is the most efficient 3D matching vision technology currently available. Its AI-powered system can quickly process large amounts of 3D data and determine the position and orientation of a workpiece. The technology adapts the robot's trajectory in real-time and our proprietary software is 100 times faster than leading algorithms, and can work with any hardware

The solution reduces automation costs and improves automation flexibility by enabling it in all types of environments: structured, semi-structured and unstructured. Real-time robot guidance makes it possible to react dynamically to unplanned events.

B. Components

GuideNOW is composed of the following components:

	GuideNOW
Camera	Intel realsense d435 with industrial casing
Controller	HP ProDesk 405 G8
Cables	1 USB3.1 cable 5m 1 Ethernet cable 3m
Software	1x GuideNOW Studio license for Inbrain programming 1x Robot Execution Software License for robot servo control
Other	1x mount for all UR e-Series & UR20 (design in appendix) Calibration board

C. Communication and interface

The 3D camera is connected to the Controller via USB 3.1 and the robot is connected to the Controller via ethernet cable.

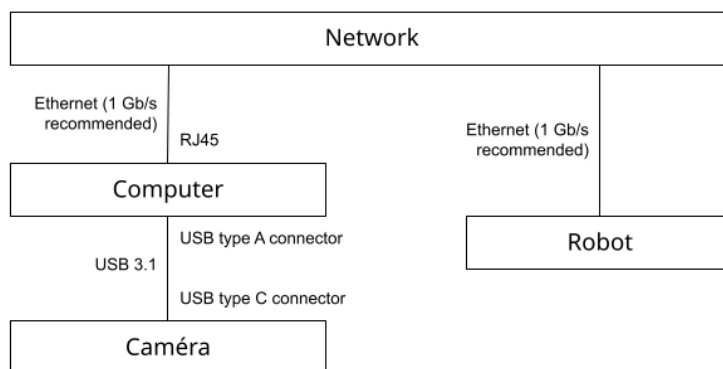

D. How it works

Set-up

After mounting the camera on the robot, Inbrain is set-up and trained offline using GuideNOW studio, where the CAD model of the workpiece and any necessary infrastructure from the environment (jigs, table, cell) can be imported. The whole process lasts no more than 15 min.

Runtime

GuideNOW uses a 3D camera to accurately detect the position of the part as soon as it appears in camera FoV. Depending on the process there are two functions available.

- Dynamic Process:

If the part is moving during the process, GuideNOW will continuously apply trajectory offset using the part position estimation from Inbrain

- Fixed Process:

If the part is not moving during the process. GuideNOW will use multiple part position estimation to accurately update the part reference frame at the beginning of the process.

II. Features, benefits and uses cases

A. Features

- Camera

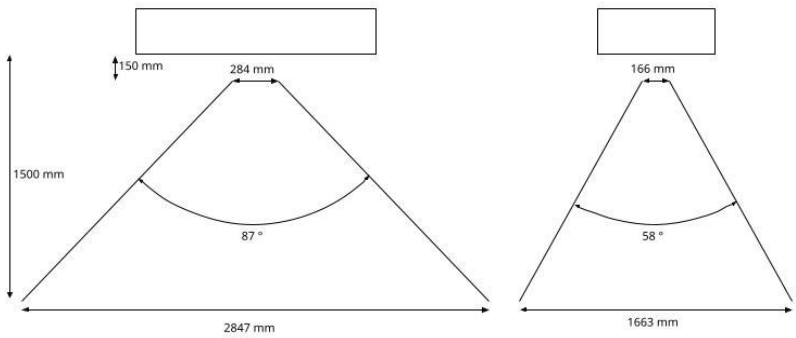
Camera	Intel realsense d435 with industrial casing
Technology	Active depth stereo (IR based)
Resolution	640x480
Power consumption	max. 700mA @5V
Connection	USB A plug
Norme	IP 65
Mounting system	Robot mounted
Working range	
Size	110*60*60

- Inbrain
 - Model based part detection & tracking
- GuideNOW studio
 - Scene definition (position and orient the part and the robot)
 - Inbrain training
 - Inbrain performance testing
 - Web browser support (Chrome, Firefox)

B. Benefits

The Inbolt real-time guidance system provides many benefits to the end user:

- Reduces automation complexity: the vision system is easy to program by the end-user, and does not require additional lighting systems. Also, thanks to trajectory realignment there is no need anymore for correcting the trajectories inline after OLP.
- Improves flexibility: no jigs, custom tooling are needed anymore. Therefore it is now possible to work on many different products on a same line and to rapidly recondition cells to launch new references. For customers with a large diversity of parts, automation is now possible.
- Improves efficiency: real-time time trajectory realignment makes it possible to reduce the cycle time. And finally, because the Inbolt system is able to refresh the position of a part at a very high frequency, it is now possible to easily automate moving lines.

The different components of GuideNOW offer real advantages in production:

3D Camera

- Off-the-shelf sensor
- Agnostic to lighting conditions

Inbrain

- Robust & reactive robot guidance
- 80ms latency from point cloud generation to new robot coordinates
- Hardware agnostic - any 3D camera can be used

GuideNOW studio

- Off-line set-up for reduced commissioning time
- Handles all formats of CAD data

C. Use cases

Most use cases can be addressed with the inbolt system as it remains very horizontal, providing solely offset to an already programmed robot trajectory. The limits of the systems are listed at the end of the spec sheet.

- Fixed stations/continuous moving lines: the system functions in both environments as the core technology of inbolt is to provide high-frequency coordinates
- Processes:
 - Assembly: tightening, screwdriving, mastic/glue application, etc.
 - Finishing operations: deburring, sanding, painting, etc.
 - Handling:
 - parts singled out on a moving conveyor
 - organized parts in bins/pallets with no overlap/clutter

III. Configuration

A. Robot compatibility

This chart shows the performance for the supported robot brand (current):

Robot manufacturer	Universal robot	ABB	FANUC
Status	Available	Coming November 2023	Coming Q1 2024
Compatible robot or controller	E-series & UR20		
Frequency of control	500 Hz		
Communication protocol	RTDE input_double_register [24 to 29] input_int_register[24 to 27] output_int_register[24 to 25]		
Max speed of the part that the robot can follow	300 mm/s		
Application	URcap		
Certification	UR+		
Additional information	Link to GuideNOW on UR+ website		

B. Basic runtime communication diagram

Note: regarding UR, the communication between the GuideNOW Controller and UR will be through an URcap.

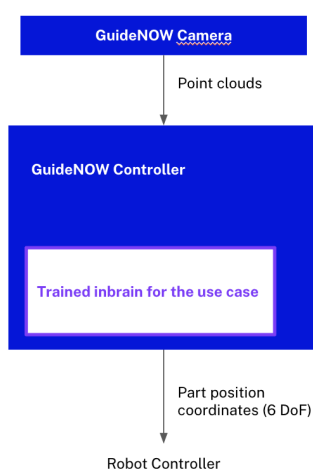

C. Hardware Setup

Inbolt provides a mount to fix the camera to the flange of the robot, you can fix the camera where you want, however the optimal position is to be located at 20 cm from the part at the time of action. Keep in mind that the FOV of the camera is $87^{\circ} \times 58^{\circ}$, the more the tracked part will be part of the FOV of the camera, the better the accuracy will be, but the camera does not have to be aimed at the action.

If you are using your own mount, please make sure that the camera is well fixed and will not move with time, this could lead to accuracy and tracking errors and a recalibration process would be necessary

D. GuideNOW Studio - Web application

Inbolt provides a web application (GuideNOW Studio) in order to set up and program the solution. The process is as follow:

- Create a new project
- Upload and visualize the part CAD model (stl format supported)
- Set the current (at the time of setup) part position/rotation relative to the robot base
- Tracking algorithm (Inbrain) training
- Verify the part current position/rotation relative to the robot base using the 3d sensor
- Automatic recording of 3d data and evaluation of the trained algorithm against real world data

IV. Specifications

A. Inbrain performance

Camera distance from the part while performing a process	Between 1.5m and 10cm Optimal distance: 30 cm
Optimal localization environment	- One part in the field of view of the camera (no multi-part tracking) - No overlapping parts
Part types & sizes	From 10x10cm up to 3x3m / no transparent parts
Total computing latency	80 ms
Output value	Coordinates of the part
Accuracy	1mm in dynamic environments 0.5mm on fixed parts

B. GuideNOW detailed performance with current certified camera

The performance of GuideNOW with the current certified camera is defined by the following information:

Acquisition time	40ms	Image acquisition time by the Inbolt camera.
Detection time	200ms	Time it takes for the algorithm to detect the part.
Refresh time	40ms	Time it takes for the algorithm to return the position of the part once the part is already recognized.
Total robot position refresh time	80ms	Our algorithm refresh time (40ms) + latency to communicate the new coordinates to the robot (40ms).
Static precision	0.5mm	The accuracy with which the robot will go to a given point after catching the part, at constant speed on moving line or fixed station.
Dynamic precision	Depends on the speed of the part	Overrun distance after an instantaneous stop of the part.
Speed variation		The speed variations the part can undergo without disturbing the robot.

1. Time performance

The time performance can be divided into three distinct stages:

- The first is the acquisition time of the camera which remains constant: 40 milliseconds.
- Then comes the detection time, this depends on the complexity of the geometry of the part (explained below in [performance detection](#)) and is between 150 and 250 ms. This detection time is only taken into account once when the part enters the camera's field of view.
- Once the part is detected, the refresh rate of our algorithms to return the precise position of the room is 40 ms on average.

During the tracking, the total time is 80 ms, this time is then compensated by our algorithms to control the robot at its maximum frequency.

2. Catch up time (for moving parts only)

The catch time represents the time it takes the robot to catch up with the part once detected by our algorithms. It depends on the robot model and the speed at which the part is moving.

Below is the graph representing the catch time for a URe series.

Catch up time

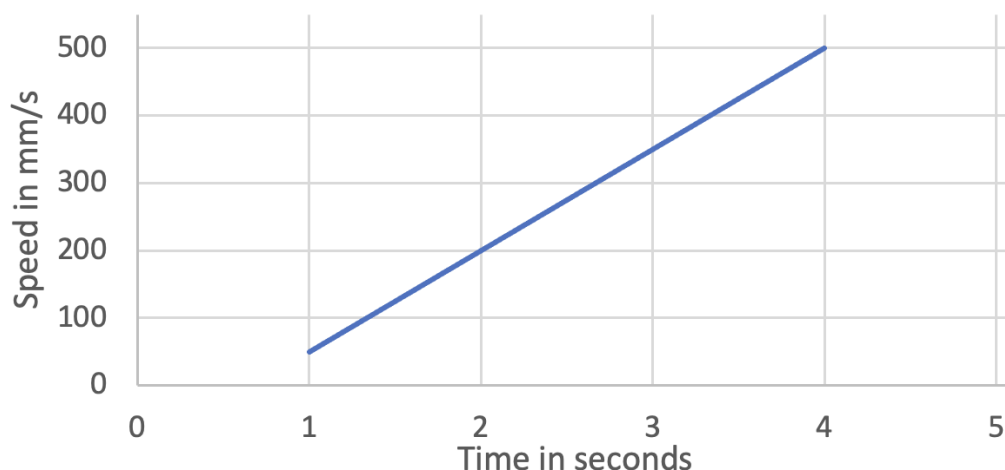

The equation behind this graph is $catch\ up\ time = (speed + 100) / 150$.

Note : this graph is for information purposes only, these values may vary depending on the distance of the robot from the part at the time of detection

3. Dynamic precision (for moving parts only)

If the speed of the tracked part varies too abruptly, it may prevent the system from working properly. The part will still be tracked but the robot will not be able to perform its action (e.g. screwing a bolt, applying glue at the desired place ...). It is defined by the overrun in millimeters of the robot after an instantaneous stop of the line.

Dynamic precision

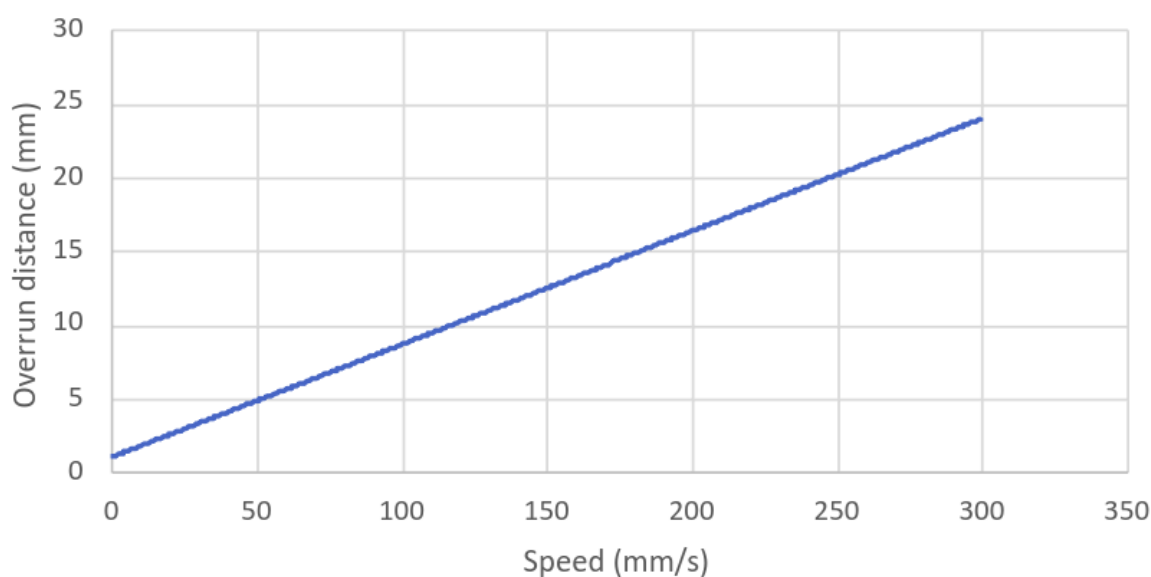

Note : Once the speed variation is finished, the robot catches up with the part and the process can continue without any problem.

While the part is continuously moving, accuracy is 1mm.

If the line stops with a deceleration lower than 100 mm/s², the overrun distance can be considered null.

4. Detection performance

The detection performance depends on the geometry of the part, as well as on the quality of the CAD model.

- The geometry: the geometry of the part should have as few symmetries as possible. Moreover, the part must have a minimum dimension of 10x10cm. The more the part has geometric features, the better the performance will be but the current sensor doesn't see small features (holes smaller than 3 cm in diameter for instance).
- Occlusion and CAD non conformity: the algorithm can tackle occlusion and small variation between the CAD model and the reality. In the testing scenarios the algorithm has a decreased performance (detection time and static precision) if more than 20% of the data is corrupted.
Tooling that attaches to the part can be included in the CAD model to improve performance.
- The quality of the CAD model: the CAD model must be in STL format and must not have any geometric error. Other formats will be supported in the future.

C. Warnings

Inbolt software doesn't currently integrate the robot physical limits. Thus if the part movement exceeds what the robot is capable of, the robot will most likely raise an error.

Inbolt software doesn't currently integrate collision detection. Thus, make sure when programming the process that any potential movement of the part/robot will not cause a collision.

Inbolt software doesn't currently integrate the singularity detection. Thus, make sure when programming the process that any potential movement of the part/robot will not cause a robot singularity.

Inbolt software doesn't allow camera recalibration while activated during the process. Make sure the camera mount and its mountings points (screws) are not likely to be modified after set-up calibration. It is recommended to use rigid material for the camera mount.