

Cobra 450, 500, and 650 Robots

User's Guide



Copyright Notice

The information contained herein is the property of Omron Adept Technologies, Inc., and shall not be reproduced in whole or in part without prior written approval of Omron Adept Technologies, Inc. The information herein is subject to change without notice and should not be construed as a commitment by Omron Adept Technologies, Inc. The documentation is periodically reviewed and revised.

Omron Adept Technologies, Inc., assumes no responsibility for any errors or omissions in the documentation. Critical evaluation of the documentation by the user is welcomed. Your comments assist us in preparation of future documentation. Please submit your comments to: techpubs@adept.com.

Copyright © 2018 - 2019 by Omron Adept Technologies, Inc. All rights reserved.

Any trademarks from other companies used in this publication
are the property of those respective companies.

Created in the United States of America

Table of Contents

Chapter 1: Introduction	9
1.1 Product Description	9
Cobra 450, 500, and 650 Robots	9
eMotionBlox-40M	10
SmartController EX (Option)	11
1.2 How Can I Get Help?	12
Related Manuals	12
Chapter 2: Safety	13
2.1 Dangers, Warnings, and Cautions	13
Alert Levels	13
Alert Icons	13
Falling Hazards	13
Special Information	14
2.2 Safety Precautions	14
User's Responsibilities	14
General Hazards	15
Qualification of Personnel	15
2.3 What to Do in an Emergency or Abnormal Situation	16
Releasing the Brakes	16
Releasing an E-Stop	16
2.4 Customer Responsibilities	17
2.5 Robot Behavior	17
Hardstops	17
Limiting Devices	17
Singularities	18
2.6 Intended and Non-intended Use	18
Intended Use of the Robot	18
Non-Intended Use	18
2.7 Additional Safety Information	19
Manufacturer's Declaration of Incorporation	19
Robot Safety Guide	19
T20 Manual Control Pendant (Option)	19
Disposal	19
Chapter 3: Robot Installation	21
3.1 Transport and Storage	21
3.2 Inspecting the Equipment	21

Before Unpacking	21
Upon Unpacking	21
3.3 Repacking for Relocation	21
3.4 Environmental and Facility Requirements	22
3.5 Mounting the Robot	22
Mounting Surface	22
Mounting Holes	23
Mounting Procedure	24
3.6 Decommissioning the Robot	26
Chapter 4: eMotionBlox-40M	27
4.1 Introduction	27
4.2 Connectors on eMB-40M Interface Panel	28
4.3 eMB-40M Operation	29
Status LED	29
Status Panel	29
Brake Release Connector	36
4.4 Connecting Digital I/O to the System	38
4.5 Using Digital I/O on eMB-40M XIO Connector	39
Optional I/O Products	41
XIO Input Signals	41
XIO Output Signals	43
XIO Breakout Cable	46
4.6 Mounting the eMB-40M	48
Dimensions and Mounting Holes	48
Mounting Clearances	49
Chapter 5: Cable Installation, Standard	51
5.1 System Cables (without SmartController EX option)	51
List of Cables and Parts	52
Cable Installation Overview	53
Optional Cables	55
5.2 Installing the ACE Software	55
5.3 Cable Connections to Robot	56
Chapter 6: Conveyor Option Installation	57
6.1 System Cables, with Two Conveyor Encoders	57
Cable Installation Overview	59
6.2 System Cables, with Six Conveyor Encoders (SmartController EX)	61
6.3 Optional Cables	63
XIO Breakout Cable	63

DB9 Splitter Cable	63
eAIB/eMB - Force/EXPIO, Belt, RS232 Cable	63
SmartController EX Belt Encoder Y-Adapter Cable	64
Chapter 7: Cable Installation, SmartController	67
7.1 System Cables, with SmartController	67
List of Cables and Parts	68
Cable Installation Overview	69
Optional Cables	70
7.2 Installing the SmartController EX	71
7.3 Installing the ACE Software	71
7.4 Connecting the PC to the SmartController	72
7.5 Cable Connections to Robot	72
7.6 Cable Connections from eMB-40M to SmartController	73
Chapter 8: AC/DC Power and Grounds	75
8.1 Cable List	75
8.2 Connecting 24 VDC Power to eMB-40M	75
Specifications for 24 VDC Power	75
Details for 24 VDC Mating Connector	76
Procedure for Creating 24 VDC Cable	76
Installing the 24 VDC Cable	77
8.3 Connecting 200-240 VAC Power	78
Specifications for AC Power	78
Details for AC Mating Connector	80
Procedure for Creating 200 to 240 VAC Cable	81
Installing AC Power Cable to eMB-40M	82
8.4 Grounding the Robot System	82
Ground Point on eMB-40M	83
User Ground Holes on Robot Interface Panel	84
Robot-Mounted Equipment Grounding	84
Chapter 9: User Connections	85
9.1 User Connections on Robot	85
User Air Lines	85
User Electrical Lines	85
Tool Flange	87
Mounting Options for User Connections	88
9.2 Installing User-Supplied Safety Equipment	88
Emergency Stop Circuits	94
Remote Manual Mode	96
User Manual/Auto Indication	96
User High Power On Indication	96

Remote High Power On/Off Control	97
High Power On/Off Lamp	97
Remote Front Panel or User-Supplied Control Panel Usage	97
Remote Pendant Usage	98
Chapter 10: System Operation	99
10.1 Status Panel Codes	99
10.2 Front Panel Option	99
10.3 Initial Power-up of the System	101
Verifying Installation	101
System Start-up Procedure	102
Running the ACE Software	102
Enabling High Power	103
Verifying E-Stop Functions	104
Verify Robot Motions	104
10.4 Learning to Program the Cobra 450, 500, and 650 Robots	104
Chapter 11: Optional Equipment	105
11.1 Installing End-Effectors	105
11.2 Add-on Equipment	105
SmartController EX	105
SmartVision MX	105
T20 Pendant	105
Front Panel	105
Power Cable Kit - P/N 04972-000	107
XIO Breakout Cable	107
Y Cable	107
eAIB XBELT IO Adapter Cable	107
Belt Encoder to M12 Y-Adapter Cable	107
Brake Release Box	107
Installing and Using the Brake Release Box	108
Chapter 12: Maintenance	111
12.1 Periodic Maintenance Schedule	111
Warning Labels	111
Checking Safety Systems	115
Checking Robot Mounting Bolts	116
Lubricate Ball Screw (Joint 3)	116
Replacing Encoder Battery Pack	118
Inspecting Timing Belts	121
12.2 Non-Periodic Maintenance	121
Replacing the eMB-40M Amplifier	121
Commissioning a System with an eMB-40M	122
E-Stop Configuration Utility	124

E-Stop Verification Utility	125
Teach Restrict feature Configuration Utility	125
Teach Restrict feature Verification Utility	126
Changing the Lamp in the Front Panel Option High-Power Indicator	127
Chapter 13: Technical Specifications	131
13.1 Dimension Drawings	131
Robot Dimensions	131
Mounting Dimensions	134
13.2 Robot Specifications	138
Physical	138
Performance	139
Stopping Distances and Times	140

Revision History

Revision code	Date	Revised Content
01	February, 2018	Original release
02	June, 2018	<ul style="list-style-type: none"> • Added SmartController EX as an option. • Added or modified system cable drawings accordingly.
03	July, 2018	<ul style="list-style-type: none"> • Added Cobra 500 and Cobra 650 robots. • Modified graphics for translation. • Added Status Code chapter and enhanced status code content. Removed unused status codes. • Changed some alerts from Warning to Danger. • Corrected eMB-40M Ethernet ports description. • Added checks for existence and legibility of warning labels on eMB-40M. • Corrected some incorrect part numbers, added others. • Minor text fixes.
04	March, 2019	<ul style="list-style-type: none"> • Added WEEE Disposal information. • Replaced www.ia.omron.com/global_network with www.ia.omron.com. • Updated copyright for 2019. • Updated Chapter 2: Safety with new format and information. • Removed references to obsolete sDIO unit. • Added complete status code table to chapter 4. • Improvements to figures and tables. • Corrected cable part number in section System Cables, with Six Conveyor Encoders (SmartController EX) • Added new and improved optional cable details in Chapter 6: System Cables, with Six Conveyor Encoders (SmartController EX) • Added cable clearance dimensions from robot back plate in Chapter 13: Technical Specifications. • Added detail to Power Cable Kit in Chapter 5: Cable Installation, Standard. • Added Motor Power and Encoder Cable minimum bending radius details to Chapter 5: Cable Installation, Standard. • Adjusted text in Emergency Stop Circuits and Line E-Stop Input in Chapter 9: User Connections. • Added a note about typical IO Blox configurations in Chapter 4: eMotionBlox-40M. • Dual-Robot Configuration Guide renamed to Single and Multiple Robot Configuration Guide

Chapter 1: Introduction

1.1 Product Description

Cobra 450, 500, and 650 Robots

The Cobra 450, 500, and 650 are high-performance, four-joint SCARA robots (Selective Compliance Assembly Robot Arm). Joints 1, 2, and 4 are rotational; Joint 3 is translational. See Figure 1-2. for a drawing of the robot joint locations and motions.

NOTE: The robot motors are powered by an eMB-40M servo-controller/amplifier. The robot can be controlled by the eMB-40M, running eV+, or an optional SmartController EX motion controller, which also runs eV+.

Mechanical specifications for the Cobra 450, 500, and 650 robots are provided in Technical Specifications on page 131.



Figure 1-1. Cobra 450 Robot

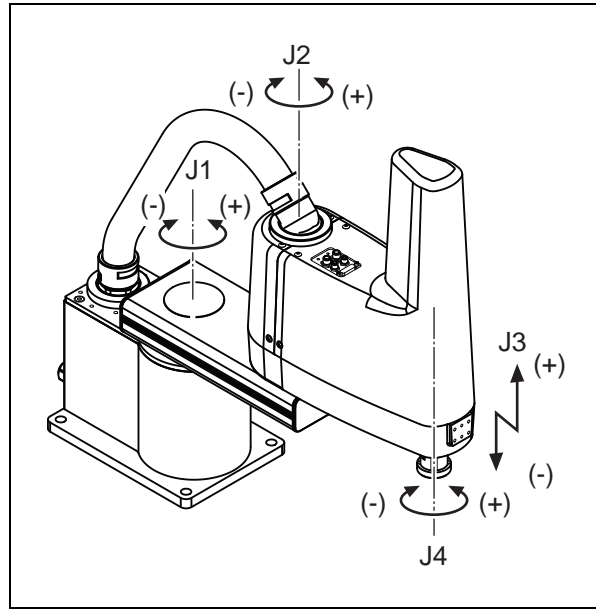

Figure 1-2. Robot Joint Motions

Key	Meaning	Key	Meaning
J1	1st Joint	J3	3rd Joint
J2	2nd Joint	J4	4th Joint

eMotionBlox-40M

The eMotionBlox-40M (eMB-40M) Distributed Servo Controller contains the amplifiers to power the high-power motors of the Cobra 450, 500, and 650 robots, and runs the eV+ operating system for motion control of the robot.

The eMB-40M features:

- Four AC servo motor amplifiers
- Emergency stop circuitry
- High servo rate, to deliver low positional errors and superior path-following
- Sine wave commutation delivers low cogging torque and improved path-following
- Digital feed-forward design maximizes efficiency, torque, and velocity
- Integral temperature sensors and status monitoring for maximum reliability
- Two-digit diagnostics display for easy troubleshooting

NOTE: The eMB-40M has connectors for the Motor Power and Robot Encoder cables that are connected to the robot interface panel at the factory. You will need to connect the free ends of these to the eMB-40M.

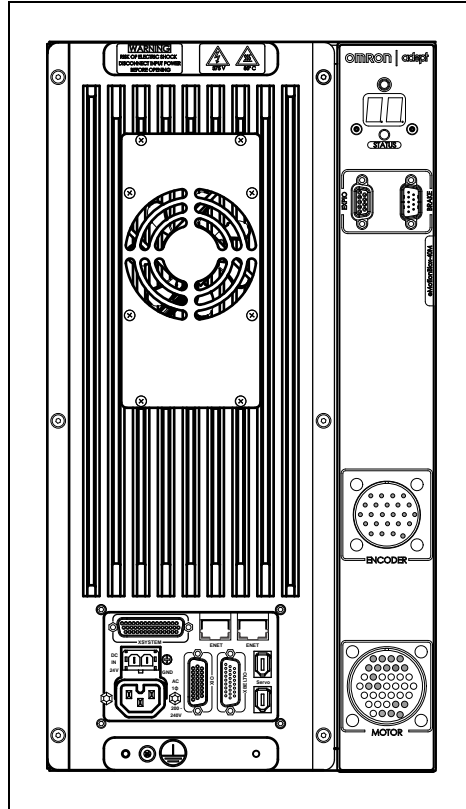

Figure 1-3. eMotionBlox-40M

SmartController EX (Option)

The SmartController EX can be added for applications requiring more processing power and connectivity in a motion controller. The SmartController is designed to work with the eMB-40M and the SmartVision MX vision controller.

The SmartController adds support for four additional conveyors, as well as other options. The SmartController EX uses the eV+ Operating System (as does the eMB-40M). It offers scalability and support for IEEE 1394-based digital I/O and general motion expansion modules. The IEEE 1394 interface is the backbone of SmartServo, the distributed controls architecture supporting our products. The SmartController also includes Fast Ethernet and DeviceNet.

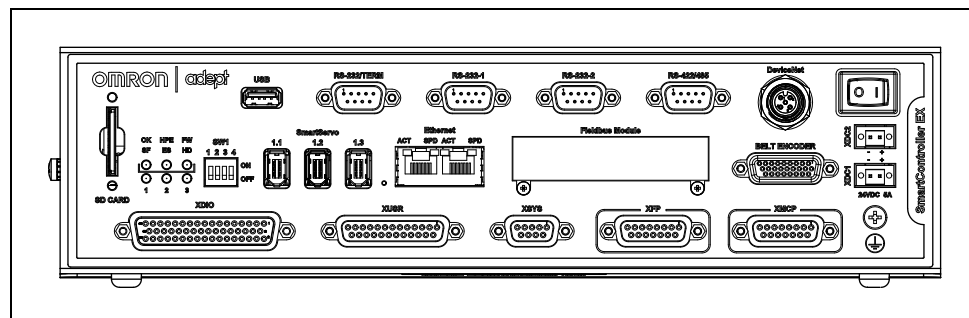

Figure 1-4. SmartController EX Motion Controller

1.2 How Can I Get Help?

You can access information sources on our corporate web site:

<https://www.ia.omron.com>

Related Manuals

This manual covers the installation, operation, and user maintenance of a Cobra 450, 500, and 650 robot system. There are additional manuals that cover programming the system, reconfiguring installed components, and adding other optional components. See the following table.

Table 1-1. Related Manuals

Manual Title	Description
<i>Robot Safety Guide</i>	Contains safety information for our robots.
<i>ACE User's Guide</i>	Instruction for the use of the ACE software. This is available from the Help tab within the ACE software.
<i>T20 Pendant User's Guide</i>	Describes the optional T20 pendant.
<i>SmartVision MX User's Guide</i>	Instructions for use of the optional SmartVision MX industrial PC.
<i>SmartController EX User's Guide</i>	Contains information on the installation and operation of the SmartController EX.
<i>IO Blox User's Guide</i>	Describes the IO Blox product.
<i>Single and Multiple Robot Configuration Guide</i>	Contains cable diagrams and configuration procedures for a single and multi-robot system. This requires a SmartController EX.

2.1 Dangers, Warnings, and Cautions

Alert Levels

There are three levels of alert notation used in our manuals. In descending order of importance, they are:



DANGER: Identifies an imminently hazardous situation which, if not avoided, is likely to result in serious injury, and might result in death or severe property damage.



WARNING: Identifies a potentially hazardous situation which, if not avoided, will result in minor or moderate injury, and might result in serious injury, death, or significant property damage.



CAUTION: Identifies a potentially hazardous situation which, if not avoided, might result in minor injury, moderate injury, or property damage.

Alert Icons

The icon that starts each alert can be used to indicate the type of hazard. These will be used with the appropriate signal word - Danger, Warning, or Caution - to indicate the severity of the hazard. The text following the signal word will specify what the risk is, and how to avoid it.

Icon	Meaning	Icon	Meaning
	This is a generic alert icon. Any specifics on the risk will be in the text following the signal word.		This identifies a hazardous electrical situation.

Falling Hazards



WARNING: PERSONAL INJURY OR PROPERTY DAMAGE RISK
If mounted incorrectly, the robot can fall over and cause serious injury to personnel or damage to itself or other equipment.

Safety Barriers

To protect personnel from coming in contact with robot unintentionally or objects entering robot's operation zone, install user-supplied safety barriers in the workcell.

Special Information

There are several types of notation used to call out special information.

IMPORTANT: Information to ensure safe use of the product.

NOTE: Information for more effective use of the product.

Additional Information: Offers helpful tips, recommendations, and best practices.

Version Information: Information on differences in specifications for different versions of hardware or software.

2.2 Safety Precautions



DANGER: PERSONAL INJURY OR PROPERTY DAMAGE RISK

A Cobra 450, 500, or 650 can cause serious injury or death, or damage to itself and other equipment, if the safety precautions in this manual are not observed.



WARNING: ELECTROCUTION RISK

During maintenance, disconnect AC power from the robot, and install a lock-out tag-out to prevent anyone from reconnecting power.

User's Responsibilities

Safe use of Cobra 450, 500, and 650 robots is your responsibility. To ensure compliance with safety rules and regulations:

- All personnel who install, operate, teach, program, or maintain the system must read this guide, read the *Robot Safety Guide*, and complete a training course for their responsibilities in regard to the robot.
- All personnel who design the robot system must read this guide, read the *Robot Safety Guide*, and must comply with all local and national safety regulations for the location in which the robot is installed.



Figure 2-1. Read Manual and Impact Warning Labels

- The robot system must not be used for purposes other than described in Intended Use of the Robot on page 18. Contact your local Omron support if you are not sure of the suitability for your application.
- The environment must be suitable for safe operation of the robot.
- The user is responsible for providing safety barriers around the robot to prevent anyone from accidentally coming into contact with the robot when it is in motion.
- Power to the robot and its power supply must be locked out and tagged out before any maintenance is performed.
- The Cobra 450, 500, and 650 must be well maintained, so that their control and safety functions continue to work properly.

General Hazards

IMPORTANT: The following situations could result in injury or damage to the equipment.

- Do not place objects on the robot.
- Do not exceed the maximum payload capacity.
- Do not exceed the maximum recommended limits given in the technical specifications. See Technical Specifications on page 131.
- Do not drop the robot, put weights on it or otherwise operate it irresponsibly.
- Do not use unauthorized parts.

Qualification of Personnel

It is the end-user's responsibility to ensure that all personnel who will work with or around robots have attended an appropriate Omron training course and have a working knowledge of the system. The user must provide the necessary additional training for all personnel who will be working with the system.

As noted in this and the Robot Safety Guide, certain procedures should be performed only by skilled or instructed persons. For a description of the level of qualification, we use the standard terms:

- **Skilled persons** have technical knowledge or sufficient experience to enable them to avoid the dangers, electrical and/or mechanical
- **Instructed persons** are adequately advised or supervised by skilled persons to enable them to avoid the dangers, electrical and/or mechanical

All personnel must observe industry-prescribed safety practices during the installation, operation, and testing of all electrically-powered equipment.

IMPORTANT: Before working with the robot, every entrusted person must confirm that they:

- Have the necessary qualifications
- Have received the guides (both this user's guide, and the Robot Safety Guide)
- Have read the guides
- Understand the guides
- Will work in the manner specified by the guides

2.3 What to Do in an Emergency or Abnormal Situation

Press any E-Stop button (a red push-button on a yellow background) and then follow the internal procedures of your company or organization for an emergency or abnormal situation. If a fire occurs, use CO₂ to extinguish the fire.

Releasing the Brakes

In case of an emergency or abnormal situation, the inner and outer robot arms can be manually moved without high power. However, only qualified personnel who have read and understood this User's Guide and *Robot Safety Guide* should manually move the robot into a safe state. Joint 3 is held by a brake, which can only be released with an optional brake box attached to the BRAKE connector. This requires 24 V power to the robot.



WARNING: PERSONAL INJURY RISK

Cobra 450, 500, and 650 robots are not collaborative robots. They require a dedicated work area that will prevent personnel from coming into contact with them during operation.

Releasing an E-Stop



CAUTION: PERSONAL INJURY OR PROPERTY DAMAGE RISK

If the robot's E-Stop is triggered, ensure that the cause of the E-Stop is resolved, and all surrounding areas are clear before releasing the E-Stop.

After the E-Stop button has been manually released, the robot will wait until the motors are manually enabled.

There are two ways to enable the motors:

- Enable power through ACE software installed on your PC
- Press the ROBOT POWER button on the Pendant

Once the motors are enabled, the robot will wait two seconds and then resume commanded motion, if there is adequate space to maneuver.

2.4 Customer Responsibilities

To achieve full compliance with ISO-10218, the customer will need to add their own:

- E-Stop button

The circuits for this are shown in Figure 9-5.

- High Power enable button

The circuit for this is shown in Figure 9-6.

- Automatic/Manual switch

The circuit for this is shown in Figure 9-6.

- Brake-release button

This needs to be within the robot workcell.

You can wire this to the eMB-40M BRAKE input for this function.

Refer to Brake Release Connector on page 36.

The customer will also need to add their own High Power lamp

- This is an amber or yellow lamp (5 V LED) that is on whenever high power is supplied to the robot.
- This must be either on the robot or within the workcell.
- The circuit for this is shown in Figure 9-5. and Figure 9-6.

2.5 Robot Behavior

Hardstops

If the Cobra 450, 500, or 650 runs into one of its hardstops, the robot's motion will stop completely, an envelope error will be generated, and power will be cut to the robot motors.

The robot cannot continue to move after hitting a hardstop until the error has been cleared.

The Cobra 450, 500, and 650's hardstops are capable of stopping the robot at any speed, load, and maximum or minimum extension.

Limiting Devices

There are no dynamic or electro-mechanical limiting devices provided by Omron Adept Technologies, Inc. The robot does not have safety-rated soft axis or space limiting.

However, the user can install their own safety rated (category 0 or 1) dynamic limiting devices if needed, that comply with ISO 10218-1, Clause 5.12.2.

Singularities

No singularities exist that cause a hazardous situation with a Cobra 450, 500, or 650 robot.

2.6 Intended and Non-intended Use

Intended Use of the Robot



DANGER: PERSONAL INJURY

Cobra 450, 500, and 650 robots are not collaborative robots. They require a dedicated work area that will prevent personnel from coming into contact with them during operation.

The normal and intended use of does not create hazards.

The Cobra 450, 500, and 650 robots have been designed and constructed in accordance with the relevant requirements of IEC 60204-1.

The Cobra 450, 500, and 650 robots are intended for use in parts assembly and material handling for payloads up to 5.0 kg. See Technical Specifications on page 131 for complete specifications. Refer to the *Robot Safety Guide* for details on the intended use of our robots.

Guidelines for safe use:

- Clean, dry mounting surfaces — surfaces that are routinely kept free of debris and liquids.
- Temperature — 5 to 40°C (41 to 104°F), with a recommended humidity range of 5% to 90%, non-condensing.

Non-Intended Use

The Cobra 450, 500, and 650 are not intended for use in any of the following situations:

- Use in the presence of ionizing or non-ionizing radiation
- Use in potentially explosive atmospheres
- Use in medical or life saving applications
- Use in a residential setting. They are for industrial use only
- Use before performing a risk assessment
- Where the equipment will be subject to extremes of heat or humidity

Non-intended use of robots can:

- Cause injury to personnel
- Damage itself or other equipment
- Reduce system reliability and performance

If there is any doubt concerning the application, ask your local Omron support to determine if it is an intended use or not.

2.7 Additional Safety Information

We provide other sources for more safety information:

Manufacturer's Declaration of Incorporation

This lists all standards with which the robot complies. The Manufacturer's Declarations for the Cobra 450, 500, and 650 robots and other products are in the *Manufacturer's Declarations Guide*.

Robot Safety Guide

The Robot Safety Guide, which ships with every robot system, provides detailed information on safety for Omron Adept Technologies, Inc. robots. It also gives resources for information on relevant standards.

T20 Manual Control Pendant (Option)

The protective stop category for the pendant enable switch is category 1, which complies with the requirements of ISO 10218-1. The pendant is designed in accordance with the requirements of IEC 60204-1 and ISO 13849. The E-Stop button is ISO 13850 compliant.

NOTE: Omron Adept Technologies, Inc. does not offer a cableless (wireless) pendant.

The manual control pendant can only move one robot at a time, even if multiple robots are connected to a SmartController EX, and the pendant is connected to the SmartController EX.

Disposal



Dispose of in accordance with applicable regulations.

Customers can contribute to resource conservation and protecting the environment by the proper disposal of WEEE (Waste Electronics and Electrical Equipment). All electrical and electronic products should be disposed of separately from the municipal waste system via designation collection facilities. For information about disposal of your old equipment, contact your local Omron support.

Chapter 3: Robot Installation

3.1 Transport and Storage



WARNING: PERSONAL INJURY OR EQUIPMENT DAMAGE.

The robot crate should be loaded or unloaded with a fork lift. Two people should work together when loading or unloading the robot.

This equipment must be shipped and stored in a temperature-controlled environment, within the range -25 to $+60^{\circ}\text{C}$ (-13 to 140°F). The recommended humidity range is 35 to 90 percent, non-condensing. It should be shipped and stored in the supplied packaging, which is designed to prevent damage from normal shock and vibration. You should protect the package from excessive shock and vibration.

The robot must always be stored and shipped in an upright position in a clean, dry area that is free from condensation. Do not lay the crate on its side or any other non-upright position: this could damage the robot.

3.2 Inspecting the Equipment

Before Unpacking

Carefully inspect all shipping crates for evidence of damage during transit. If any damage is indicated, request that the carrier's agent be present at the time the container is unpacked.

Upon Unpacking

Before signing the carrier's delivery sheet, please compare the actual items received (not just the packing slip) with your equipment purchase order and verify that all items are present and that the shipment is correct and free of visible damage.

If the items received do not match the packing slip, or are damaged, do **not** sign the receipt. Contact your local Omron support as soon as possible.

If the items received do not match your order, please contact your local Omron support immediately.

Inspect each item for external damage as it is removed from its container. If any damage is evident, contact your local Omron support (see How Can I Get Help? on page 12).

Retain all shipping containers and packaging materials. These items may be necessary to settle claims or, at a later date, to relocate equipment.

3.3 Repacking for Relocation

If the robot or other equipment needs to be relocated, reverse the steps in the installation procedures that follow. Reuse original packing containers and materials, if possible, and follow all safety notes used for installation. Improper packaging for shipment will void your warranty. Attach the red shipping brackets between the end of Joint 2, the tool flange, and the top of the

robot base to help centralize the center of gravity. The robot must always be shipped in an upright orientation. Specify this to the carrier if the robot is to be shipped.

3.4 Environmental and Facility Requirements

The robot system installation must meet the operating environment requirements shown in the following table.

Table 3-1. Robot System Operating Environment Requirements

Ambient temperature	5 to 40°C (41 to 104°F)
Humidity	35 to 90%, non-condensing
Pollution degree (Specified by IEC 60664-1)	2
Vibration	Less than 0.2 G during operation. Ideally, the environment should meet Vibration Condition VC-B.
Electrical Noise, Immunity	Complies with IEC EN 61000-6-2: Electromagnetic compatibility (EMC) - Part 6-2: Generic standards - Immunity for industrial environments
Electrical Noise, Emission	Complies with IEC EN 61000-6-4: Electromagnetic compatibility (EMC) - Part 6-4: Generic standards - Emission standard for industrial environments
Grounding class	Protective Earth grounding is Class C. (<10 Ω)
Robot protection class	IP20 (NEMA Type 1)

IMPORTANT: The robot is rated at IP20, which means that it is not designed or intended for operation in wet environments.

3.5 Mounting the Robot

Mounting Surface

The Cobra 450, 500, and 650 are designed to be mounted on a smooth, flat, level surface. The mounting surface must be rigid enough to prevent vibration and flexing during robot operation. We recommend a steel plate at least 15 mm thick mounted to a rigid tube frame. Excessive vibration or mounting flexure will degrade robot performance.

The flatness of the mounting surface should be 0.2 mm or less. The mounting surface should be machined and its surface roughness should be 25S or less.

The robot, operating at high speed, can generate up to 3500 N of reaction force in the X-axis, Y-axis, and Z-axis, which is transmitted to the mounting bolts and plate. Inadequate mounting can cause the robot to slip or vibrate.

Mounting Holes

The following figure shows the mounting hole pattern for the Cobra 450, 500, and 650.

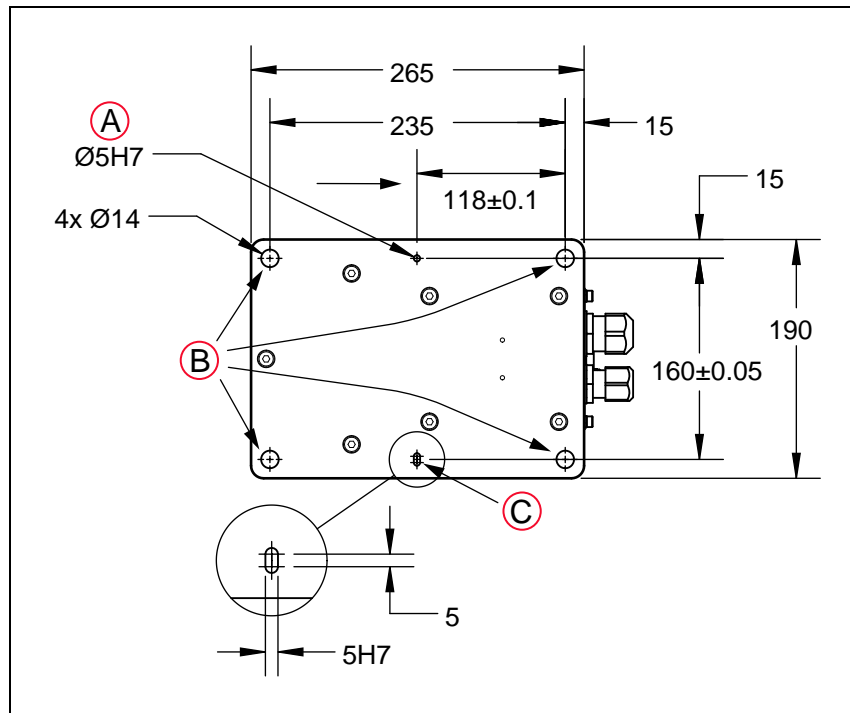

Figure 3-1. Mounting Hole Pattern for Robot, Bottom View (Units in mm)

Key	Meaning	Key	Meaning	Key	Meaning
A	Positioning Pin Hole	B	Base Mounting Holes	C	Positioning Pin Slot

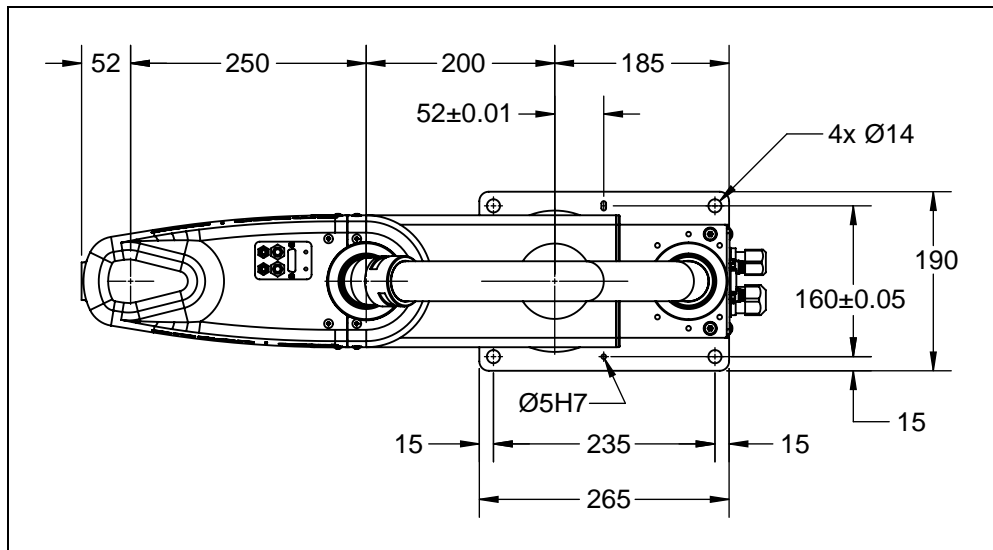

Figure 3-2. Cobra 450 Top View

NOTE: On the left side of the base (viewed from above, from the robot interface panel) is a round hole, and on the right side is a slot. These should be used with user-supplied 5 mm dia. positioning pins in the mounting surface. The hole and slot in the robot base are shown in the preceding two figures. Note that the first drawing is looking up from underneath the robot base. Using positioning pins improves the ability to remove and reinstall the robot in the same position.

See the preceding figure for the dimensions of the mounting and positioning holes in the robot base.

1. Drill four M12 bolt holes for machine bolts (user-supplied).
You can either tap these for the bolts, or you can drill thru-holes, and use nuts and washers on the other side of the mounting surface.
2. Drill two dowel pin holes, dia. 5 mm H7, for the positioning pins.
3. Install two user-supplied positioning pins into the two dia. 5 H7 holes in the mounting surface.

Mounting Procedure

NOTE: It is assumed that you have removed the upper shell of the crate, and now have just the robot and related items on the shipping pallet.



WARNING: PERSONAL INJURY/PROPERTY DAMAGE

Do not remove the red shipping brackets or move the robot arms until the robot has been secured to its mounting surface. Failure to comply could result in the robot falling and causing either personnel injury or property damage.

1. Remove all of the boxes from the shipping pallet, leaving just the robot bolted to the pallet.

These will include the box containing the eMB-40M and a box containing the SmartController EX, if you ordered one.

2. Remove the four bolts securing the robot base to the pallet.

One person should support the robot while another person removes the bolts.

3. With two people, lift the robot and position it directly over the mounting surface.

The robots weigh approximately 30 to 33 kg (66 to 73 lb), including the factory-installed cables, with no options installed.



WARNING: PERSONAL INJURY.

Two people should lift and mount the robot. See the following figure.

**CAUTION: PROPERTY DAMAGE**

Do not lift the robot by any part other than Joint 1 and the shipping bracket, as shown in the following figure.



Figure 3-3. Lifting the Robot

4. Slowly lower the robot while aligning the base with the mounting holes and positioning pins in the mounting surface.

**CAUTION: PROPERTY DAMAGE**

The base casting of the robot is aluminum and can easily be dented if bumped against a harder surface.

5. Verify that the robot does not rock on the mounting surface before tightening the mounting bolts. If it rocks, either there is something between the robot and the mounting surface, or the mounting surface is not flat.
6. Install the user-supplied mounting bolts and washers. Tighten the bolts to 110 N·m.

**WARNING: PERSONAL INJURY/PROPERTY DAMAGE**

The center of mass of the robot may cause it to fall over if the robot is not secured with the mounting bolts.

Table 3-2. Mounting Bolt Torque Specifications

Standard	Size	Specification	Torque
Metric	M12	ISO Property Class 10.9	110 N·m

NOTE: Check the tightness of the mounting bolts one week after initial installation, and then recheck every 6 months. See Checking Robot Mounting Bolts on page 116 for periodic maintenance.

- Remove the red shipping brackets that hold the tool flange and the end of Joint 2 to the robot base during shipment.

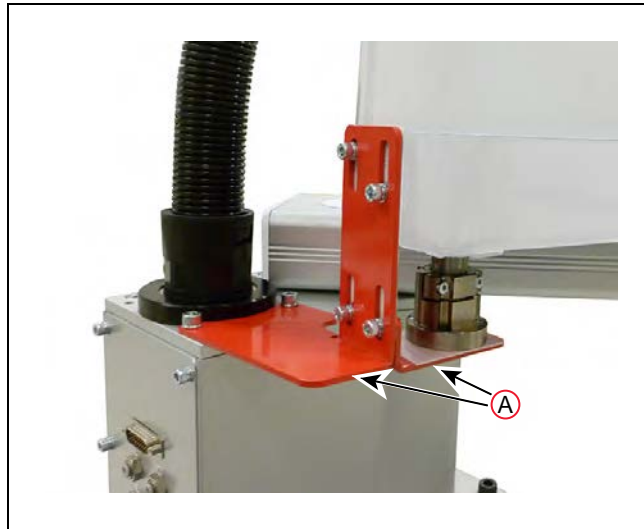

Figure 3-4. (A) Red Shipping Brackets

NOTE: Install the shipping brackets before loosening the mounting bolts any time the robot is to be moved from one mounting location to another.

3.6 Decommissioning the Robot

If the robot is being decommissioned, ensure that Joint 2 is secured with the shipping brackets, to stabilize the robot. Also make sure that it is lifted by two people.



WARNING: PERSONAL INJURY.
Use two people to lift the robot.

Chapter 4: eMotionBlox-40M

4.1 Introduction

The eMotionBlox-40M (eMB-40M) is a distributed servo controller and amplifier. It has a dedicated digital signal processor to communicate, coordinate, and execute servo commands.

The eMB-40M consists of:

- a distributed servo amplifier
- a RISC processor for servo loop control
- a node on the IEEE 1394 network
- a power controller that uses single-phase AC power, 200-240 Volts
- a 2-digit alpha-numeric status panel display, showing operating status and fault codes

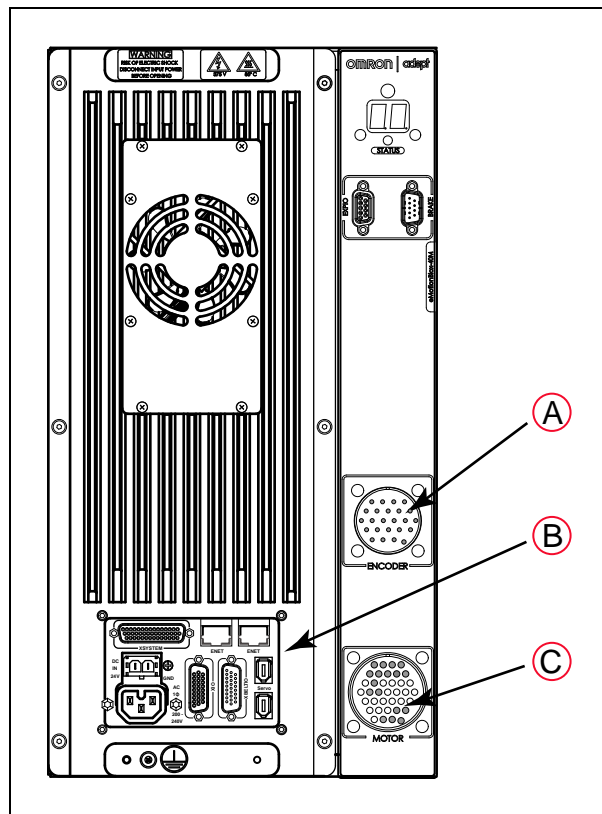

Figure 4-1. eMB-40M Front View

Key	Meaning	Key	Meaning	Key	Meaning
A	Robot Encoder Connector	B	eMB-40M Interface Panel	C	Motor Power Connector

4.2 Connectors on eMB-40M Interface Panel

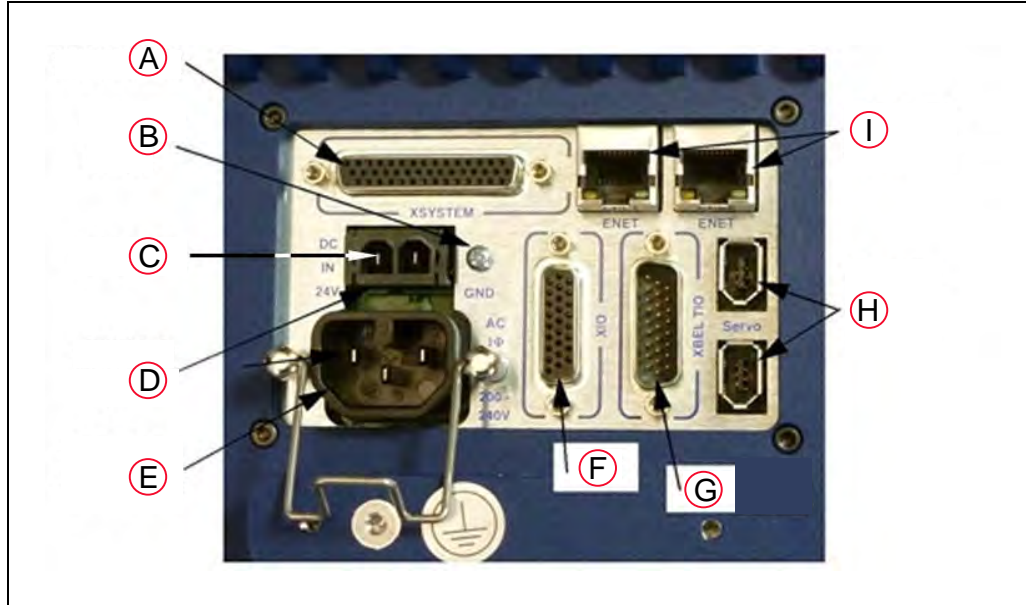

Figure 4-2. eMB-40M Interface Panel

See the following table for descriptions of the interface panel connectors.

Table 4-1. Connectors on the eMB-40M Interface Panel

Key	Name	Meaning
A	XSYSTEM	Connects to the eAIB XSYSTEM cable or the eAIB XSYS cable (SmartController EX).
B	Ground Point	For cable shield from user-supplied 24 VDC cable.
C	+24 V Pin	+24 V pin of the 24 VDC connector.
D	24 VDC	For user-supplied 24 VDC power. The mating connector is provided.
E	200/240 VAC	For 200-240 VAC, single-phase, input power. The mating connector is provided.
F	XIO	For user I/O signals for peripheral devices. Provides 8 outputs and 12 inputs. See Connecting Digital I/O to the System on page 38 for connector pin allocations for inputs and outputs. That section also contains details on how to access these I/O signals. (DB-26, high density, female)
G	XBELTIO	Adds two belt encoders, EXPIO, and an RS-232 interface, which is reserved for future use.
H	Smart-Servo	For the IEEE 1394 cable from the controller
I	ENET	Two Ethernet ports are available. One will be needed to connect to a PC running ACE software.

4.3 eMB-40M Operation

Status LED

The Status LED indicator is located near the top of the eMB-40M. See the following figure. This is a bi-color, red and green LED. The color and blinking pattern indicates the status of the robot. See the following table.

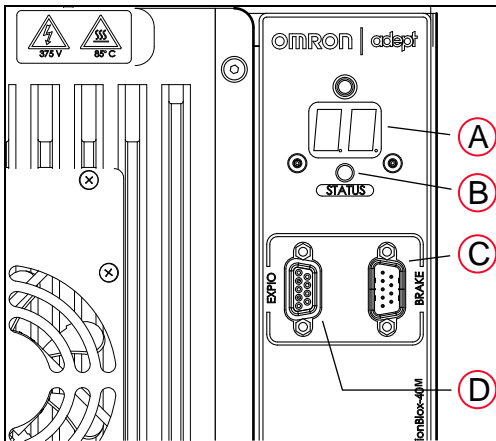

Figure 4-3. Controls and Indicators on eMB-40M

Key	Meaning	Key	Meaning
A	Status Panel Display	C	Brake Connector
B	Status LED Indicator	D	EXPIO Connector

Table 4-2. Status LED Definition

LED Status	Description
Off	24 VDC not present
Green, Slow Blink	High Power Disabled
Green, Fast Blink	High Power Enabled
Green/Red Blink	Selected Configuration Node*
Red, Fast Blink	Fault, see Table 4-3.
Solid Green or Red	Initialization or Robot Fault

* This is used in ACE when configuring Firewire Nodes, to identify which robot is selected:
ACE> SmartController Object > Configure > Configure Firewire Nodes

Status Panel

The status panel, shown in the preceding figure, displays alpha-numeric codes that indicate the operating status of the eMB-40M. The following table gives a summary of the fault codes.

These codes provide details for quickly isolating problems during troubleshooting. Refer to Table 4-3. below for more detail.

In the Status Panel Codes table, the '#' in the LED column represents a single digit. The digits will be displayed as one of the following:

0	1	2	3	4	5	6	7	8	9
0	1	2	3	4	5	6	7	8	9

Table 4-3. Status Panel Codes

LED	Text	Status Code	LED	Text	Status Code
OK	OK	No Fault	h#	h#	High Temp Amp (Joint #)
ON	ON	High Power ON Status	H#	H#	High Temp Encoder (Joint #)
MA	MA	Manual Mode	HV	HV	High Voltage Bus Fault
24	24	24 V Supply Fault	I#	I#	Initialization Stage (Step #)
A#	A#	Amp Fault (Joint #)	M#	M#	Motor Stalled (Joint #)
B#	B#	IO Blox Fault (Address #)	P#	P#	Power System Fault (Code #)
BA	BA	Backup Battery Low Voltage	PR	PR	Processor Overloaded
AC	AC	AC Power Fault	RC	RC	RSC Fault
D#	D#	Duty Cycle Exceeded (Joint #)	S#	S#	Safety System Fault (Code #)
E#	E#	Encoder Fault (Joint #)	SE	SE	E-Stop Delay Fault
ES	ES	E-Stop	SW	SW	Watchdog Timeout
F#	F#	External Sensor Stop	T#	T#	Safety System Fault (Code 10 + #)
FM	FM	Firmware Mismatch	TR	TR	Teach Restrict Fault
FW	FW	1394 Fault	V#	V#	Hard Envelope Error (Joint #)

NOTE: Due to the nature of the Cobra 450, 500, and 650 bus line encoder wiring, a single encoder wiring error may result in multiple channels of displayed encoder errors. Reference the lowest encoder number displayed.

LED	Status Code	V+ Error Message	V+ Error Code	Explanation	User Action
OK	OK	None	N/A	STATUS message-High Power OFF.	None
ON	ON	None	N/A	STATUS message-High Power ON.	None

LED	Status Code	V+ Error Message	V+ Error Code	Explanation	User Action
MA	MA	None	N/A	STATUS message-Robot is in Manual Mode.	None
24	24	*RSC power failure*	-670	The 24 VDC input voltage is out of bounds (too high or low).	Check connections and voltage level from the user-supplied 24 VDC power supply.
A#	A#	*Motor Amplifier Fault*	-1018	A power amplifier fault is indicated on axis #.	Check user motor power connections for shorts or opens. Turn high power back on and restart the program. If the error persists, contact your local Omron support.
AC	AC	*RSC Power Failure*	-670	A loss of AC power was detected.	Check user AC power connections for shorts or opens. Turn high power back on and restart the program. If the error persists, contact your local Omron support.
B#	B#	None	N/A	IO-Blox communications error with IO-Blox (#).	Check user IOBlox connections for shorts or opens. Check IOBlox address switches for proper configuration. Cycle power to the control system. If the error persists, contact your local Omron support.
BA	BA	None	N/A	The encoder backup battery is low.	Replace the encoder backup battery.
D#	D#	*Duty-cycle exceeded* Mtr #	-1021	The indicated motor (#) has been driven hard for too long a period of time. The servo system has disabled power to protect the robot hardware.	Turn high power back on; reduce the speed and/or acceleration for the motion that was in progress or for motions that pre-

LED	Status Code	V+ Error Message	V+ Error Code	Explanation	User Action
					ceded that motion. Repeat the motion that failed.
E#	E#	*Encoder Fault*	-1025	The servo system has detected an encoder fault.	User actions vary by product. Please reference individual robot manuals for appropriate actions.
ES	ES	*E-STOP detected by robot*	-643	An E-STOP condition has been detected by the robot.	This is a normal response to many E-STOP conditions. Remove the source of the ESTOP and re-enable high power.
F1	F1	*E-STOP detected by robot*	-643	The End-Of-Arm Break-away Sensor has tripped (open circuit). Reporting of this error can be enabled / disabled via ACE.	Re-close the break-away circuit and re-enable high power.
FM	FM	None	N/A	Firmware version mismatch.	Contact your local Omron support.
FW	FW	*1394 communications timeout*	-927	The IEEE 1394 communications system has failed to initialize or has lost communications with the SmartController.	This will occur normally if the SmartController is powered down separately from the robot systems. If it occurs unexpectedly, check the connections and integrity of the 1394 cabling.
h#	h#	*Robot overheated*	-606	The temperature sensor on the embedded processor board has reached its temperature limit. It may be necessary to slow the motion or insert pauses to reduce overall heating.	Check for excessive ambient temperature, inadequate ventilation, and proper function of any cooling fans.
H#	H#	*Motor overheating* Mtr #	-1016	The motor encoder temperature sensor indicates an overtemperature.	Reduce the speed, acceleration and/or deceleration of the robot motions, or

LED	Status Code	V+ Error Message	V+ Error Code	Explanation	User Action
					introduce delays in the application cycle to give the motor an opportunity to cool.
HV	hV	*RSC power failure*	-670	The high-voltage DC bus for the amplifiers is out of bounds (too high or low).	This may occur when AC power is unexpectedly removed. Check AC connections and re-enable high power. If the error persists, contact your local Omron support.
I#	I#	None	N/A	Servo initialization stages. These steps normally sequence (I0, I1, ...) on the display during normal system boot.	None, unless an initialization code persists longer than 30 seconds. This may indicate servo initialization has failed. Contact your local Omron support.
M#	M#	*Motor stalled* Mtr #	-1007	A motor stall occurs when the maximum allowed torque for a given motor was applied for longer than the defined timeout period. This typically occurs when an obstacle is encountered.	Check for obstacles and free movement of all joints. Turn high power back on and repeat the motion that failed.
P0	P0	*Power system failure* Code 0	-1115	The dual-channel brake circuit has reported a cyclic check error.	Contact your local Omron support.
P1	P1	*Power system failure* Code 1	-1115	The power system has unexpectedly turned off power.	On PA-4 chassis, further information may be indicated on the PA-4 status lights. Refer to Adept PA-4 Power Chassis User's Guide for details. Contact your local Omron support if the error persists.
P2	P2	*Power system failure* Code 2	-1115	The high-voltage DC bus to the regenerative	Contact your local Omron support.

LED	Status Code	V+ Error Message	V+ Error Code	Explanation	User Action
				energy dump circuit has experienced an over-voltage.	
P3	P3	*Power system failure* Code 3	-1115	The regenerative energy dump circuit has exceeded its max short-term dump rating.	Contact your local Omron support.
P4	P4	*Power system failure* Code 4	-1115	The high-voltage DC bus did not discharge its voltage when expected. (Note: This error is only relevant to legacy Cobra AIB systems.)	Contact your local Omron support.
P5	P5	*Power system failure* Code 5	-1115	An inrush error was detected by the power sequencer. This means the high-voltage DC bus failed to rise at the expected rate when power was enabled.	This can occur if AC power is abruptly removed during the high-power enable sequence. If it occurs unexpectedly, contact your local Omron support.
PR	PR	None	N/A	A servo task has overrun its allotted execution window.	If the problem persists, contact your local Omron support.
RC	RC	*RSC communications failure*	-651	There is a failure to communicate with the Robot Signature Card.	Contact your local Omron support.
S0	S0	*Safety System Fault* Code 0	-1109*	The robot hardware did not detect that the front-panel high-power button was pressed prior to the servo system attempting to enable power.	Contact your local Omron support.
S1	S1	*Safety System Fault* Code 1	-1109*	The SmartController has signaled a power off condition to the robot via the HIPWR_DIS line on the XSYS interface. This fault indication typically accompanies other fault conditions that cause "fatal error" on the Smart-Controller error	Check for other messages on the SmartController that may indicate a fatal error. If the error source can be eliminated, re-enable power.

LED	Status Code	V+ Error Message	V+ Error Code	Explanation	User Action
				(such as a loss in IEEE-1394 communication).	
52	S2	*Safety System Fault* Code 2	-1109*	The safety system experienced a failure on channel 1 during the cyclic check of dual-channel power system. This may indicate a welded relay contact or other hardware failure.	If the problem persists, contact your local Omron support.
53	S3	*Safety System Fault* Code 3	-1109*	The safety system experienced a failure on channel 2 during the cyclic check of dual-channel power system. This may indicate a welded relay contact or other hardware failure.	If the problem persists, contact your local Omron support.
54	S4	*Safety System Fault* Code 4	-1109*	The internal E-STOP delay timer timed out and power has been turned off. Under normal circumstances, software sequences the shutdown prior to the timeout, averting this message.	If the problem persists, contact your local Omron support.
55	S5	*Safety System Fault* Code 5	-1109*	The power system was not properly unlocked by software during a power sequence while in manual mode.	Contact your local Omron support.
56	S6	*Safety System Fault* Code 6	-1109*	The CAT-3 hardware safety system detected an encoder OVERSPEED and power has been turned off. This circuitry is active in manual mode only, on select robots which have the CAT-3 teach mode option installed.	This fault is triggered on purpose during specific commissioning tests for the CAT-3 system. If the fault occurs during normal operation, contact your local Omron support.
59	S9	*Safety System Fault* Code 9	-1109*	A watchdog circuit that cross-checks the clocks for the dual-channel	Contact your local Omron support.

LED	Status Code	V+ Error Message	V+ Error Code	Explanation	User Action
				safety system is reporting an error.	
SE	SE	*Safety System Not Commissioned*	-648	The E-Stop Delay has not been commissioned and verified.	Commission and verify the E-Stop Delay.
SW	SW	None	N/A	Software watchdog timer timeout. On some products it is normal for this to occur momentarily during a servo reset.	If the problem persists, contact your local Omron support.
T0	T0	*Safety System Fault* Code 10	-1109	An error was detected during a software self test of a secondary safety and monitoring circuit (SRV_DIRECT / SRV_STAT).	Contact your local Omron support.
TR	TR	*Safety System Not Commissioned*	-648	The Teach Restrict feature feature has not been commissioned and verified.	Commission and verify the Teach Restrict feature feature.
V#	V#	*Hard envelope error* Mtr #	-1027	The indicated motor was not tracking the commanded position with sufficient accuracy as set by ACE.	Turn on high power and try to perform the motion at a slower speed. Make sure that nothing is obstructing the robot's motion. If the error recurs, contact your local Omron support.

Brake Release Connector

Under some circumstances you may want to manually position Joint 3 without turning on high power. If 24 VDC power is on, you can use the Brake Release connector for this. The Brake Release connector, labeled BRAKE, is on the right side of the eMB-40M below the Status LED indicator. See Figure 4-3.

The 9-pin Brake Release connector provides low-active input signals to manually release the brake on Joint 3. The digital inputs on this connector meet the same input level requirements as the XIO inputs. See XIO Input Specifications on page 41 for details.

**WARNING: INJURY OR PROPERTY DAMAGE**

When the Brake Release is activated, Joint 3 may drop to the bottom of its travel. To prevent possible damage to the equipment, make sure that Joint 3 is supported while releasing the brake and verify that the end-effector or other installed tooling is clear of all obstructions.

Table 4-4. Brake Release Connector Pinouts

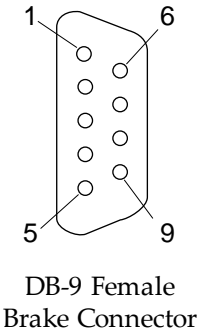
Pin #	Description	Pin Location
1	Not connected	 <p>DB-9 Female Brake Connector</p>
2	Not connected	
3	Release3_N	
4	Not connected	
5	Not connected	
6	Not connected	
7	GND	
8	Not connected	
9	24V	
Mating Connector: D-Subminiature 9-Pin Male		

4.4 Connecting Digital I/O to the System

You can connect digital I/O to the system in several ways. See the following table and figure.

NOTE: A typical IO Blox configuration is shown in Figure 4-4. Other configurations may be possible. Contact your local Omron support for more information.

Table 4-5. Digital I/O Connection Options

Product	I/O Capacity	For more details
XIO Connector on eMB-40M	12 inputs 8 outputs	Using Digital I/O on eMB-40M XIO Connector on page 39.
XDIO on optional SmartController EX	12 inputs 8 outputs	<i>SmartController EX User's Guide</i>
Optional IO Blox Devices, connect to EXPPIO connector on the eMB-40M	8 inputs, 8 outputs per device; up to four IO Blox devices per system	<i>IO Blox User's Guide</i>

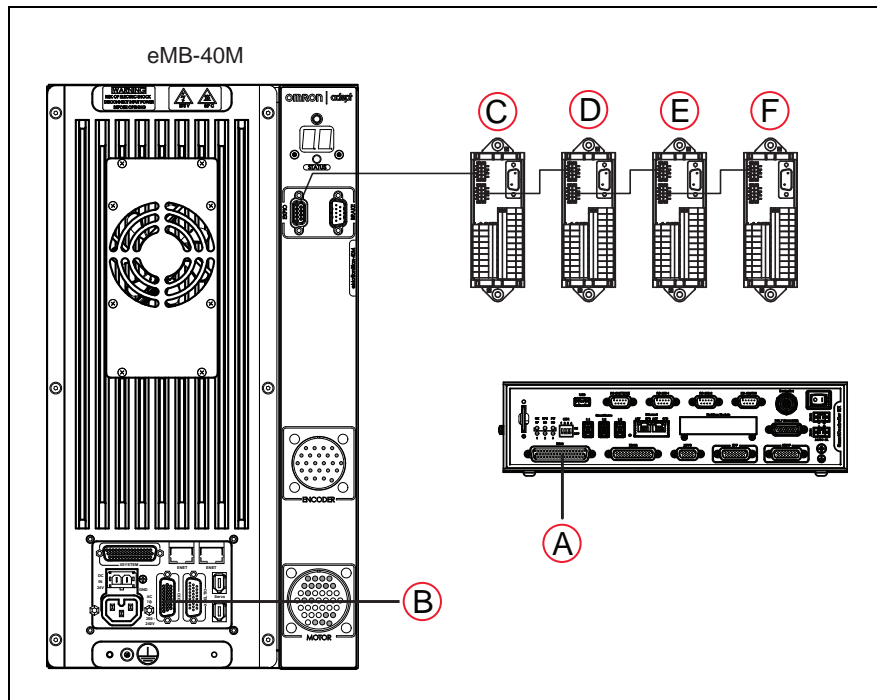

Figure 4-4. Connecting Digital I/O to the System

Table 4-6. Default Digital I/O Signal Configuration, Single Robot System

Item	Location	Type	Signal Range
A	Optional SmartController EX, XDIO connector	Inputs	1001 - 1012
		Outputs	0001 - 0008
B	eMB-40M XIO connector	Inputs	1097 - 1108
		Outputs	0097 - 0104
C	Optional IO Blox 1	Inputs	1113 - 1120
		Outputs	0105 - 0112
D	Optional IO Blox 2	Inputs	1121 - 1128
		Outputs	0113 - 0120
E	Optional IO Blox 3	Inputs	1129 - 1136
		Outputs	0121 - 0128
F	Optional IO Blox 4	Inputs	1137 - 1144
		Outputs	0129 - 0136

4.5 Using Digital I/O on eMB-40M XIO Connector

The XIO connector on the eMB-40M interface panel offers access to digital I/O, 12 inputs and 8 outputs. These signals can be used by eV+ to perform various functions in the workcell. See the following table for the XIO signal designations.

- 12 Inputs, signals 1097 to 1108
- 8 Outputs, signals 0097 to 0104

Table 4-7. XIO Signal Designations

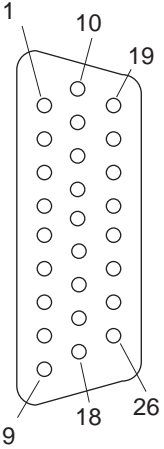
Pin No.	Designation	Signal Bank	eV+ Signal Number	Pin Locations
1	GND			 <p>XIO 26-pin female connector on eMB-40M Interface Panel</p>
2	24 VDC			
3	Common 1	1		
4	Input 1.1	1	1097	
5	Input 2.1	1	1098	
6	Input 3.1	1	1099	
7	Input 4.1	1	1100	
8	Input 5.1	1	1101	
9	Input 6.1	1	1102	
10	GND			
11	24 VDC			
12	Common 2	2		
13	Input 1.2	2	1103	
14	Input 2.2	2	1104	
15	Input 3.2	2	1105	
16	Input 4.2	2	1106	
17	Input 5.2	2	1107	
18	Input 6.2	2	1108	
19	Output 1		0097	
20	Output 2		0098	
21	Output 3		0099	
22	Output 4		0100	
23	Output 5		0101	
24	Output 6		0102	
25	Output 7		0103	
26	Output 8		0104	

Optional I/O Products

These optional products are also available for use with digital I/O:

- **XIO Breakout Cable** (P/N 04465-000), 5 m, with flying leads on user's end (see XIO Breakout Cable on page 46). It is not compatible with the XIO Termination Block mentioned below.
- **XIO Termination Block** (P/N 90356-40100), with terminals for user wiring, plus input and output status LEDs. Connects to the XIO connector with 6-foot cable. See the *XIO Termination Block Installation Guide* for details.

XIO Input Signals

The 12 input channels are arranged in two banks of six. Each bank is electrically isolated from the other bank and is optically isolated from the eMB-40M ground. The six inputs within each bank share a common source/sink line.

The inputs are accessed through direct connection to the XIO connector (see the following table), or through the optional XIO Termination Block. See the documentation supplied with the Termination Block for details.

The XIO inputs cannot be used for REACTI programming, high-speed interrupts, or vision triggers. Refer to the eV+ user guides.

XIO Input Specifications

Table 4-8. XIO Input Specifications

Parameter	Value
Operational voltage range	0 to 30 VDC
OFF state voltage range	0 to 3 VDC
ON state voltage range	10 to 30 VDC
Typical threshold voltage	$V_{in} = 8$ VDC
Operational current range	0 to 7.5 mA
OFF state current range	0 to 0.5 mA
ON state current range	2.5 to 6 mA
Typical threshold current	2.0 mA
Impedance (V_{in}/I_{in})	3.9 K Ω minimum
Current at $V_{in} = +24$ VDC	$I_{in} \leq 6$ mA
Turn on response time (hardware) Software scan rate/response time	5 μ sec maximum 16 ms scan cycle/ 32 ms max response time
Turn off response time (hardware) Software scan rate/response time	5 μ sec maximum 16 ms scan cycle/ 32 ms max response time

NOTE: The input current specifications are provided for reference. Voltage sources are typically used to drive the inputs.

Typical Input Wiring Example

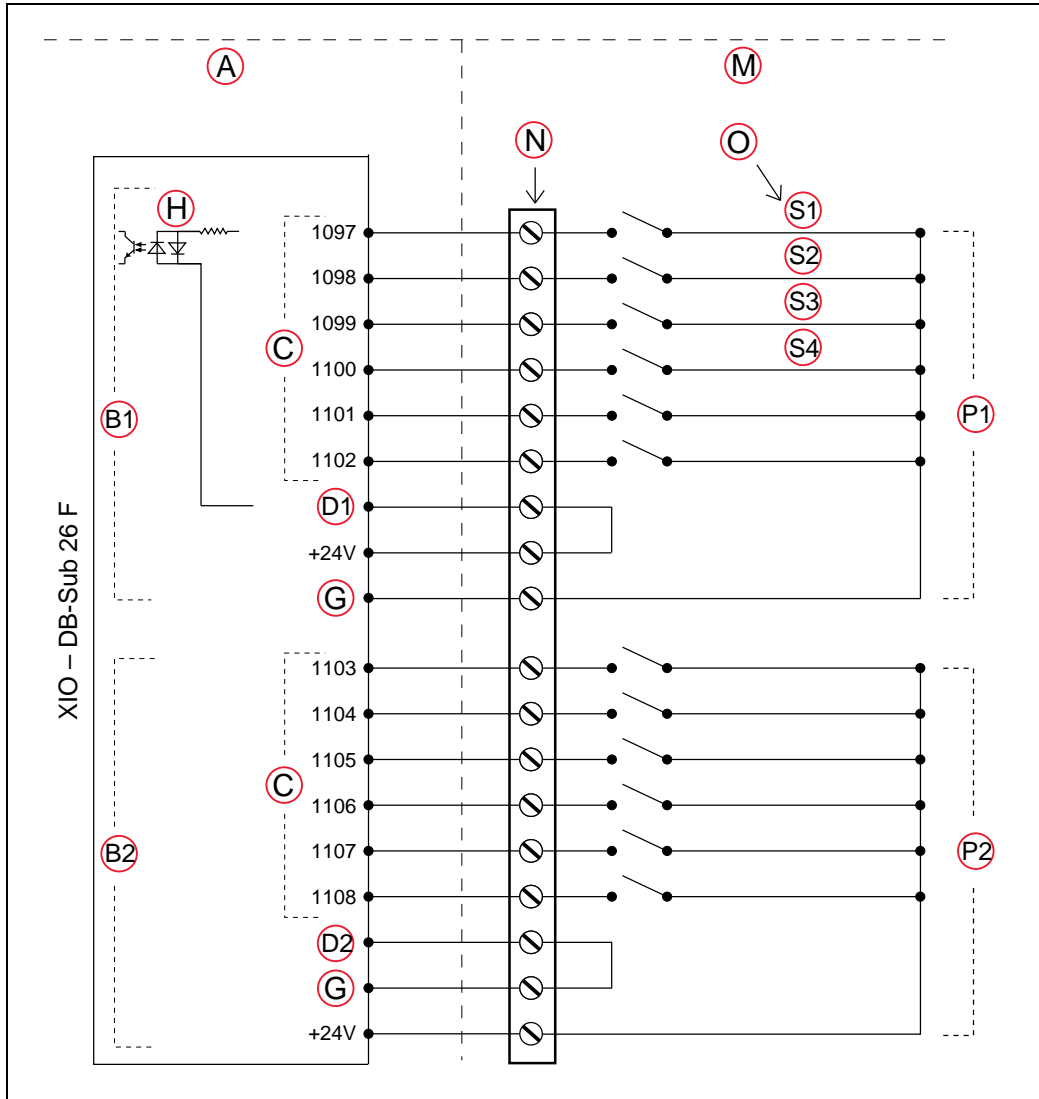

Figure 4-5. Typical User Wiring for XIO Input Signals

NOTE: The off-state current range exceeds the leakage current of XIO outputs. This guarantees that the inputs will not be turned on by the leakage current from the outputs. This is useful in situations where the outputs are looped-back to the inputs for monitoring purposes.

Key	Meaning
A	Supplied Equipment
B1	Input Bank 1
B2	Input Bank 2
C	Signals
D1	Bank 1 Common
D2	Bank 2 Common
G	Ground
H	(equivalent circuit)
M	User-Supplied Equipment
N	Wiring Terminal Block
O	Typical User Input Signals
P1	Bank 1 configured for Sinking (NPN) Inputs
P2	Bank 2 configured for Sourcing (PNP) Inputs NOTE: All Input signals can be used for either sinking or sourcing configurations.
S1	Part Present Sensor
S2	Feeder Empty Sensor
S3	Part Jammed Sensor
S4	Sealant Ready Sensor

XIO Output Signals

The eight digital outputs share a common, high-side (sourcing) driver IC. The driver is designed to supply any kind of load with one side connected to ground. It is designed for a range of user-provided voltages from 10 to 24 VDC, and each channel is capable of up to 0.7 A of current. This driver has overtemperature protection, current limiting, and shorted-load protection. In the event of an output short or other overcurrent situation, the affected output of the driver IC turns off and back on automatically to reduce the temperature of the IC. The driver draws power from the primary 24 VDC input to the eMB-40M through a self-resetting poly-fuse.

The outputs are accessed through direct connection to the XIO connector (see XIO Signal Designations on page 40), or through the optional XIO Termination Block. See the documentation supplied with the Termination Block for details.

XIO Output Specifications*Table 4-9. XIO Output Circuit Specifications*

Parameter	Value
Power supply voltage range	See Specifications for 24 VDC Power on page 75.
Operational current range, per channel	$I_{out} \leq 700 \text{ mA}$
Total Current Limitation, all channels on.	$I_{total} \leq 1.0 \text{ A @ } 50^{\circ}\text{C ambient}$ $I_{total} \leq 1.5 \text{ A @ } 25^{\circ}\text{C ambient}$
On-state resistance ($I_{out} = 0.5 \text{ A}$)	$R_{on} \leq 0.32 \Omega @ 85^{\circ}\text{C}$
Output leakage current	$I_{out} \leq 25 \mu\text{A}$
Turn-on response time	125 μsec max., 80 μsec typical (hardware only)
Turn-off response time	60 μsec . max., 28 μsec typical (hardware only)
Output voltage at inductive load turnoff ($I_{out} = 0.5 \text{ A}$, Load = 1 mH)	$(+V - 65) \leq V_{demag} \leq (+V - 45)$
DC short circuit current limit	$0.7 \text{ A} \leq I_{LIM} \leq 2.5 \text{ A}$
Peak short circuit current	$I_{ovpk} \leq 4 \text{ A}$

Typical Output Wiring Example

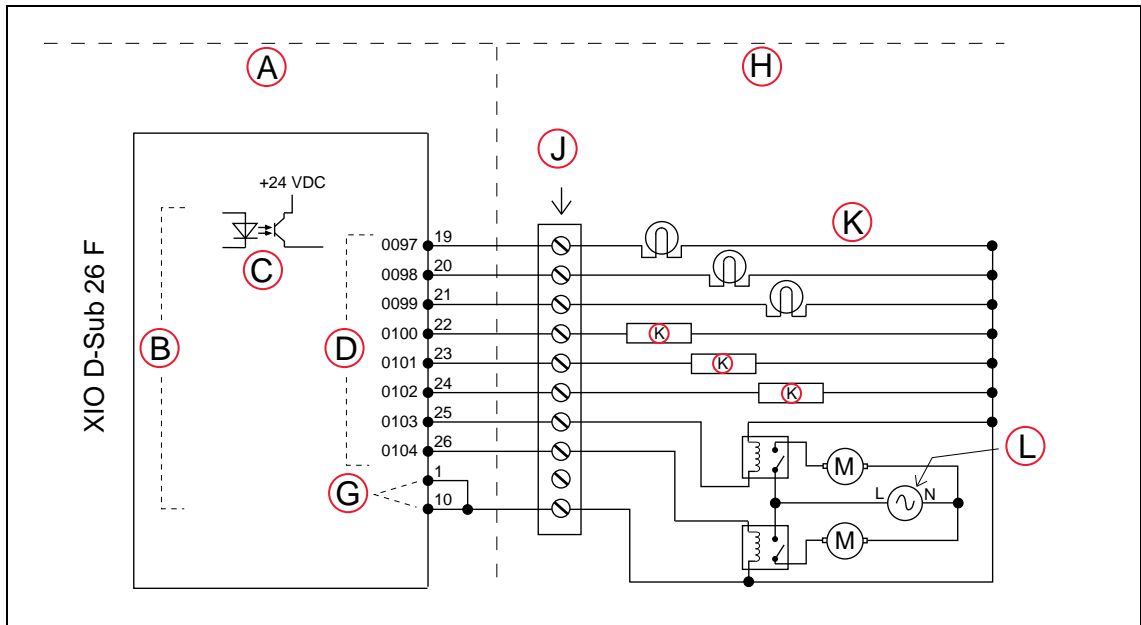

Figure 4-6. Typical User Wiring for XIO Output Signals

Key	Meaning	Key	Meaning
A	Supplied Equipment	H	User-Supplied Equipment
B	Outputs 1-8	J	Wiring Terminal Block
C	(equivalent circuit)	K	Typical User Loads
D	Signal	L	Customer AC Power 10 Supply
G	Ground	M	Motor (example of a load)

XIO Breakout Cable

The XIO Breakout cable is available as an option—see the following figure. This cable connects to the XIO connector on the eMB-40M, and provides flying leads on the user's end, for connecting input and output signals in the workcell. The cable length is 5 m (16.4 ft).

See the following table for the cable wire chart.

NOTE: This cable is not compatible with the XIO Termination Block.



Figure 4-7. Optional XIO Breakout Cable

Table 4-10. XIO Breakout Cable Wire Chart

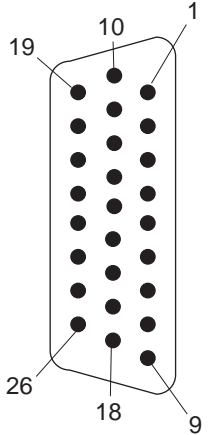
Pin No.	Signal Designation	Wire Color	Pin Locations
1	GND	White	 <p>26-pin male connector on XIO Breakout Cable</p>
2	24 VDC	White/Black	
3	Common 1	Red	
4	Input 1.1	Red/Black	
5	Input 2.1	Yellow	
6	Input 3.1	Yellow/Black	
7	Input 4.1	Green	
8	Input 5.1	Green/Black	
9	Input 6.1	Blue	
10	GND	Blue/White	
11	24 VDC	Brown	
12	Common 2	Brown/White	
13	Input 1.2	Orange	
14	Input 2.2	Orange/Black	
15	Input 3.2	Gray	
16	Input 4.2	Gray/Black	
17	Input 5.2	Violet	
18	Input 6.2	Violet/White	
19	Output 1	Pink	
20	Output 2	Pink/Black	
21	Output 3	Light Blue	
22	Output 4	Light Blue/Black	
23	Output 5	Light Green	
24	Output 6	Light Green/Black	
25	Output 7	White/Red	
26	Output 8	White/Blue	
Shell		Shield	

4.6 Mounting the eMB-40M

Dimensions and Mounting Holes

See the following figure for dimensions of the eMB-40M chassis and mounting holes.

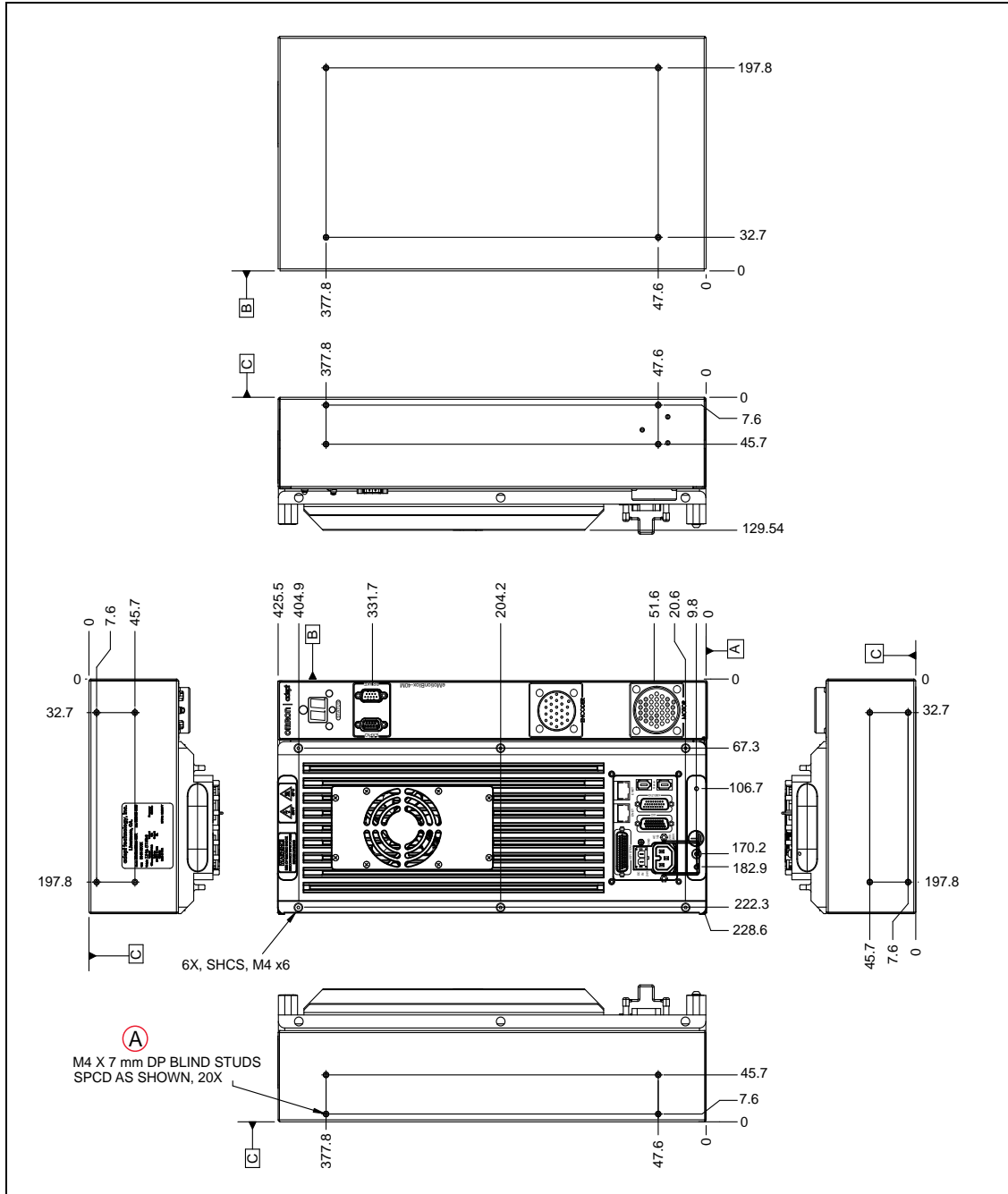

Figure 4-8. eMB-40M Mounting Dimensions (Units in mm)

A: M4 X 7 mm DP BLIND STUDS SPCD AS SHOWN, 20x

Mounting Clearances

NOTE: The mounting of the eMB-40M and all terminations at the eMB-40M must be performed in accordance with all local and national standards.

The following space must be left around the eMB-40M for proper cooling:

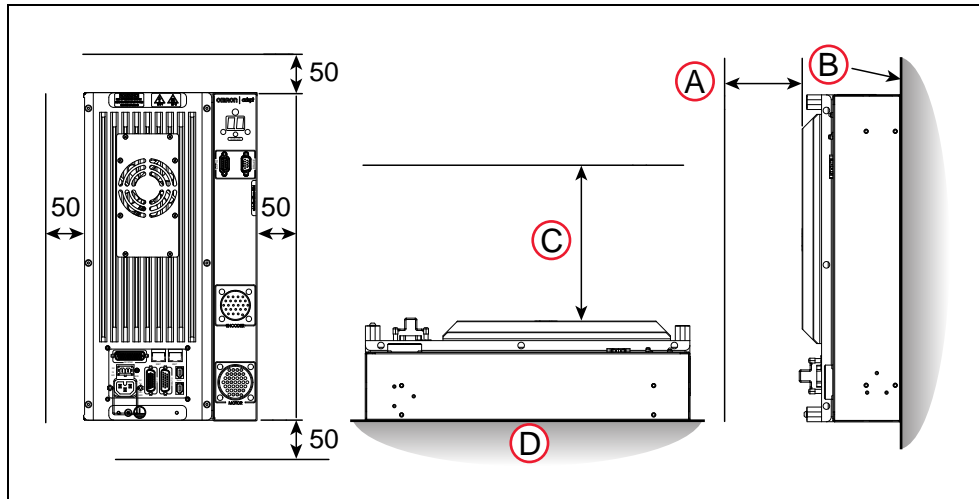

Figure 4-9. Clearance for the eMB-40M (Units in mm)

Key	Meaning
A	100 mm or more in front of Heat Sink for Wall Mounted
B	Wall
C	200 mm or more above Heat Sink for Floor Mounted
D	Floor

NOTE: These dimensions assume the eMB-40M has exposure to outside air, rather than being in a sealed container. Any sealed container would need to provide sufficient cooling for the eMB-40M's internal fan to be effective.

Surface	Air Gap
Back	0 mm
Sides	50 mm (2 inches)
Front, when wall-mounted	100 mm (4 inches)
Front, when flat-mounted	200 mm (8 inches)

Chapter 5: Cable Installation, Standard

5.1 System Cables (without SmartController EX option)

The letters in the following figure correspond to the letters in the table of cables and parts. The numbers correspond to the steps in the cable installation overview table. The tables are on the pages following the figure.

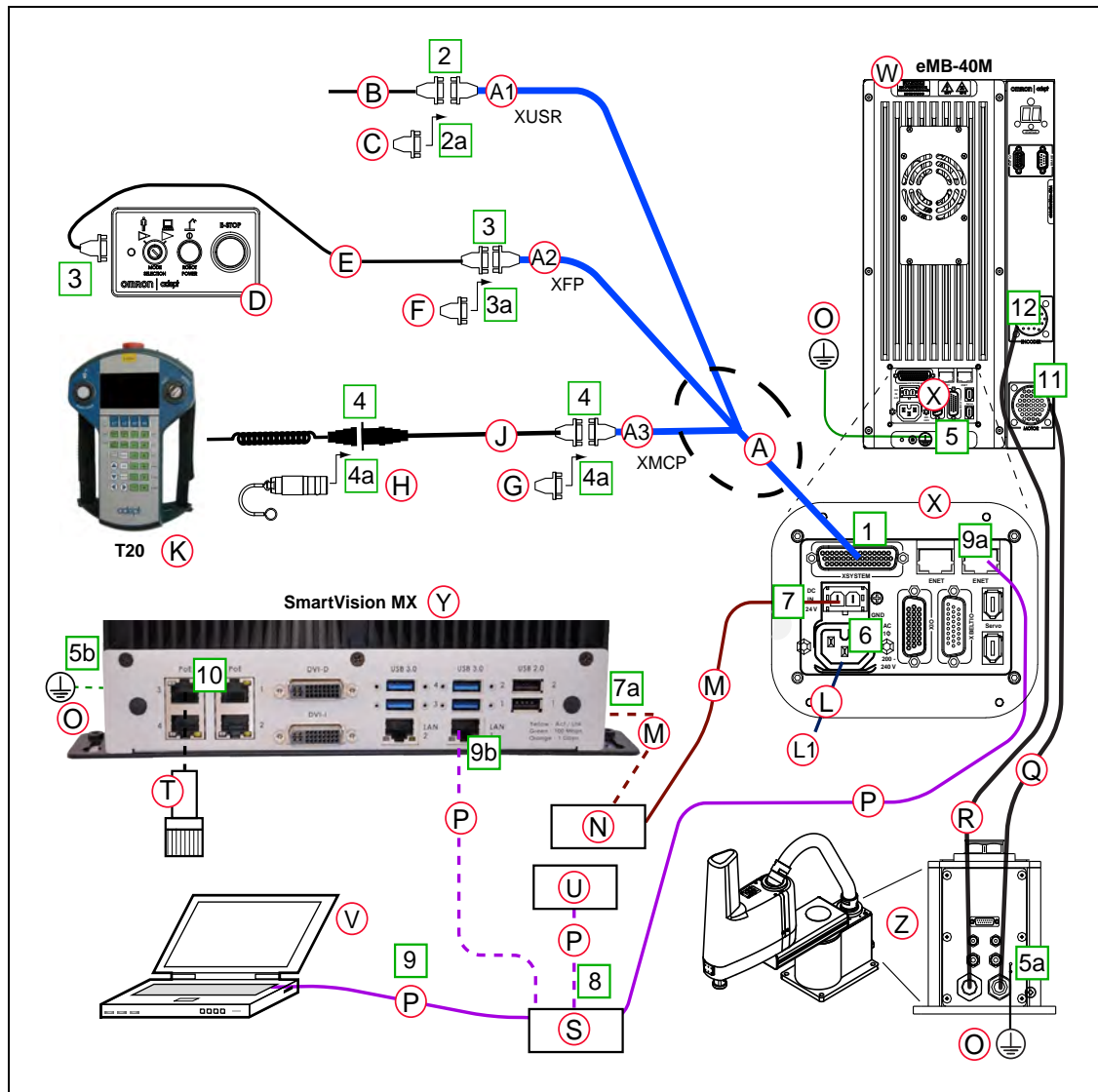

Figure 5-1. System Cable Diagram for Robot with Pendant, and Vision (Cobra 450 Shown)

The figure includes the optional T20 pendant and optional SmartVision MX.

NOTE: See Grounding the Robot System on page 82 for additional system grounding information.

List of Cables and Parts

In the Accessory box, locate the eAIB XSYSTEM cable. Connect the cables and peripherals as shown in the preceding figure. Parts and steps are covered in the following two tables.

Table 5-1. System Cables (without SmartController EX Option) Description

Part	Cable and Parts List	Part #	Standard	Option	User-Supplied
A	eAIB XSYSTEM Cable Assembly	13323-000	X		
A1	XUSR Connector		X		
A2	XFP Connector		X		
A3	XMCP Connector		X		
B	User E-Stop, Safety Gate	n/a			X
XUSR for User E-Stop/Safety Gate and Muted Safety Gate. The Jumper Plug is required if neither of these is used.					
C	XUSR Jumper Plug	04736-000	X		
D	Front Panel	90356-10358		X	X
E	Front Panel Cable	10356-10500		X	X
F	Front Panel Jumper Plug	10053-000	X		
Either Front Panel or FP plug must be used.					
G	XMCP Jumper Plug	10052-000	X		
H	T20 Bypass Plug	10048-000		X	
J	T20 Adapter Cable	10051-003		X	
K	T20 Pendant Assembly Optional T20 Pendant Kit (10046-010) includes items K, H, and J.	10054-010		X	
Either T20 Pendant, T20 Bypass Plug, or XMCP Jumper Plug must be used.					
L	VAC Power Cable	04118-000		X	X
L1	200 - 240 VAC, 10 A, Single-phase				X
M	24 VDC Power Cable	04120-000		X	X
N	24 VDC, 6 A Power Supply	04536-000		X	X
O	Ground - eMB-40M, SmartVision MX, Robot Interface				X

Part	Cable and Parts List	Part #	Standard	Option	User-Supplied
P	Ethernet Cables - ethernet switch -> PC, SmartVision MX, PLC (optional), eMB-40M	n/a			X
Q, R	Motor, Encoder Cable Harness	05701-200	X		
S	Ethernet switch	n/a			X
T	Camera and cable	n/a		X	X
U	PLC (optional)	n/a			X
V	PC running ACE Software	n/a			X
W	eMB-40M	19500-000	X		
X	eMB-40M Interface Panel	n/a	X		
Y	SmartVision MX	14189-901		X	
Z	Cobra 450, 500, and 650 Robot	17201-14500	X		

The XUSR, XMCP, and XFP jumpers intentionally bypass safety connections so you can test the system functionality during setup.



WARNING: PERSONAL INJURY/PROPERTY DAMAGE

Under no circumstances should you run a Cobra 450, 500, or 650 system, in production mode, with all three jumpers installed. This would leave the system with no E-Stops.

Cable Installation Overview

Power requirements for the SmartVision MX industrial PC are covered in that user guide. For 24 VDC, both the eMB-40M and a SmartVision MX can usually be powered by the same power supply.

Table 5-2. Cable Installation Overview Description (without SmartController EX Option)

Step	Connection	Part
1	Connect eAIB XSYSTEM cable to XSYSTEM on eMB-40M.	A
2	Connect a user E-Stop or Muted Safety Gate to the eAIB XSYSTEM cable XUSR connector or	B
2a	verify XUSR jumper plug is installed in eAIB XSYSTEM cable XUSR connector.	C
3	Connect Front Panel cable to Front Panel and eAIB XSYSTEM cable XFP connector or	D, E
3a	if no Front Panel, install FP jumper on eAIB XSYSTEM cable XFP connector. See NOTE after table.	F

5.1 System Cables(without SmartController EX option)

Step	Connection	Part
4	Connect T20 adapter cable to eAIB XSYSTEM cable XMCP connector or	J, K
4a	if no T20, install XMCP jumper or T20 Adapter Cable with T20 bypass plug.	G or H
5	Connect user-supplied ground to eMB-40M. See Grounding the Robot System on page 82.	n/a
5a	Connect user-supplied ground to robot. See Grounding the Robot System on page 82.	n/a
5b	Connect user-supplied ground to SmartVision MX.	n/a
6	Connect 200-240 VAC to VAC Input on eMB-40M Interface Panel; secure with clamp.	L
7	Connect 24 VDC to DC Input on robot interface panel.	N, M
7a	Connect 24 VDC and shield ground to SmartVision MX, if used. See SmartVision MX user's guide for location.	N, M
8	Connect Ethernet cable from PLC to switch, if a PLC is used.	P, S, U
9	Connect Ethernet cable from PC to switch.	P, S, V
9a	Connect Ethernet cable from switch to eMB-40M.	P, S, X
9b	Connect Ethernet cable from switch to SmartVision MX, if used.	P, S, Y
10	Connect optional camera and cable to SmartVision MX.	T, Y
11	Connect Motor cable from robot to eMB-40M Motor Power connector	Q, W, Z
12	Connect Encoder cable from robot to eMB-40M Robot Encoder connector	R, W, Z

NOTE: If you don't purchase the optional Front Panel, you must replace its functionality with equivalent circuits. Refer to the schematics in Installing User-Supplied Safety Equipment on page 88.

NOTE: The Motor and Encoder cables that connect the robot interface panel to the eMB-40M are installed in the robot interface panel at the factory. You will need to connect the free ends of these to the eMB-40M.

Optional Cables

NOTE: The following cables are not covered in the steps in the preceding table.

Part Description	Notes
XIO Breakout Cable , 12 inputs/ 8 outputs, 5 m	Available as option - see Using Digital I/O on eMB- 40M XIO Connector on page 39.
eAIB/eMB Force/Expio, Belt, RS-232 Three-headed Cable	Refer to Conveyor Option Installation on page 57
Power Cable Kit - contains 24 VDC and VAC power cables and 150 W Power Supply (90-264 VAC Input, 50-60 Hz)	Available as option (90565- 010)

The XIO Breakout cable is for using the I/O on the eMB-40M. See XIO Breakout Cable on page 46.

The optional eAIB/eMB Force/Expio, Belt, RS-232 Three-headed Cable splits the eAIB XBELTIO port into a belt encoder lead, an Intelligent Force Sensing or IO Blox lead, and an RS-232 lead.

5.2 Installing the ACE Software

The ACE software is installed from the documentation and ACE software USB drive.

1. Insert the drive into your PC.

If Autoplay is enabled, the software menu is displayed. If Autoplay is disabled, you will need to manually start the software.

2. Especially if you are upgrading your ACE software installation: from the ACE software menu, click Read Important Information.
3. From the ACE software menu, select:

Install the ACE Software

The ACE Setup wizard opens.

4. Follow the online instructions as you step through the installation process.
5. When the installation is complete, click Finish.
6. After closing the ACE Setup wizard, click Exit on the software menu to close the menu.

NOTE: You will have to restart the PC after installing ACE software.

5.3 Cable Connections to Robot

There are two cables between the robot and the eMB-40M: the Motor Power cable and the Robot Encoder cable, as shown in the following figure.

These cables have a minimum bending radius as follows:

- Motor Power Cable: 115 mm
- Encoder Cable: 112 mm

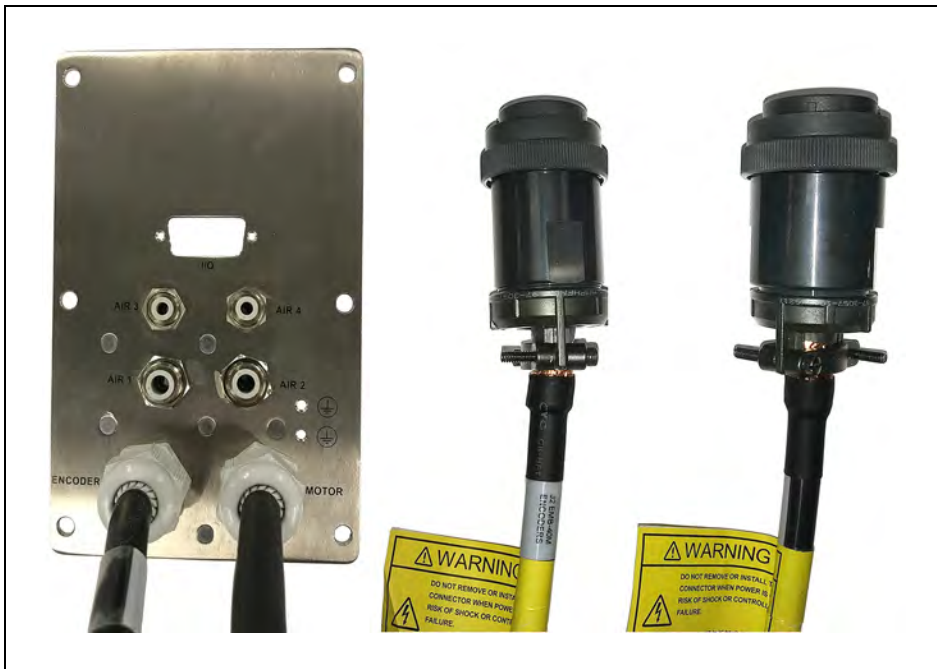

Figure 5-2. Cables in Interface Panel, Loose eMB Ends

One end of each of the cables is connected to the robot interface at the factory.

1. Connect the free end of the Motor Power cable to the Motor Power connector on the eMB-40M. Tighten the screws securely.
2. Connect the free end of the Robot Encoder cable to the Robot Encoder connector on the eMB-40M. Tighten the screws securely.



CAUTION: Verify that all connectors are fully inserted and screwed down. Failure to do this could cause unexpected robot motion. Also, a connector could get pulled out or dislodged unexpectedly.

Chapter 6: Conveyor Option Installation

6.1 System Cables, with Two Conveyor Encoders

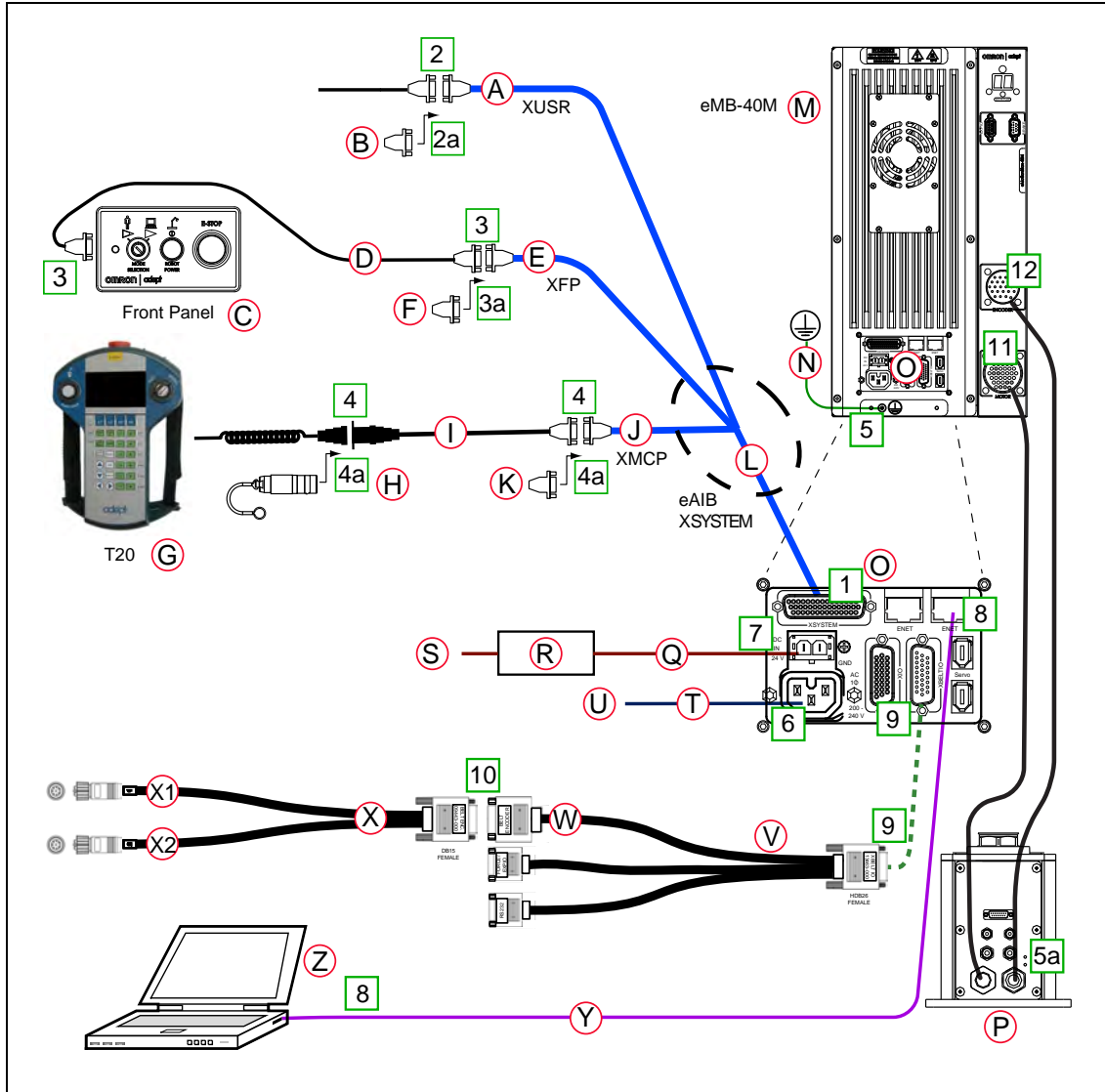

Figure 6-1. System Cable Diagram with Belt Encoders

Table 6-1. System with Belt Encoders Cable Description

	Part	Part Number	Standard	Option	User-Supplied
A	XUSR Connector	n/a	X		
B	XUSR Jumper Plug	04736-000	X		
XUSR for User E-Stop/Safety Gate and Muted Safety Gate. The Jumper Plug is required if neither of these is used					
C	Front Panel	90356-10358		X	X
D	Front Panel Cable	10356-10500		X	X
E	XFP Connector	n/a	X		
F	Front Panel Jumper Plug	10053-000	X		
Either Front Panel or FP plug must be used					
G	T20 Pendant Assembly Optional T20 Pendant Kit (10046-010) includes items G, H, and I.	10054-010		X	
H	T20 Pendant Bypass Plug	10048-000		X	
I	T20 Pendant Adapter Cable	10051-003		X	
J	XMCP Connector	n/a	X		
K	XMCP Jumper Plug	10052-000	X		
Either T20 Pendant, T20 Bypass Plug, or XMCP Jumper Plug must be used					
L	eAIB XSYSTEM Cable	13323-000	X		
M	eMB-40M	19500-000	X		
N	Ground Wire	n/a			X
O	eMB-40M Interface Panel	n/a	X		
P	Robot Interface Panel	n/a	X		
Items R, T, and U are available, as an option, in the power supply/cable kit 90565-010.					
Q	DC Power Cable	04120-		X	X

	Part	Part Number	Standard	Option	User-Supplied
		000			
R	24 VDC, 6 A Power Supply	04536-000		X	X
S	AC Power input	n/a			X
T	AC Power Cable	04118-000		X	X
U	200 - 240 VAC 10 A, single-phase	n/a			X
V	eAIB/eMB - Force/ Expio, Belt, RS-232 Cable	13463-000		X	
Refer to Conveyor Option Installation on page 57.					
W	Belt Branch of V	n/a		X	
X	Belt Encoder to M12 Y-Adapter Cable	09443-000		X	
The following two items, X1 and X2, are part of Encoder Kit P/N 09742-001.					
X1	to Belt Encoder 1	n/a		X	
X2	to Belt Encoder 2	n/a		X	
Y	Ethernet from PC to eMB-40M	n/a			X
Z	PC running ACE Software	n/a			X

Cable Installation Overview

Table 6-2. System with Belt Encoders Cable Installation Description

Step	Connection	Part
1	Connect eAIB XSYSTEM cable to XSYSTEM on eMB-40M.	A
2	Connect a user E-Stop or Muted Safety Gate to the eAIB XSYSTEM cable XUSR connector or	B
2a	verify XUSR jumper plug is installed in eAIB XSYSTEM cable XUSR connector.	C
3	Connect Front Panel cable to Front Panel and eAIB XSYSTEM cable XFP connector or	D, E
3a	if no Front Panel, install FP jumper on eAIB XSYSTEM cable XFP connector. See NOTE after table.	F
4	Connect T20 adapter cable to eAIB XSYSTEM cable XMCP connector or	I, J

Step	Connection	Part
4a	if no T20, install XMCP jumper or T20 Adapter Cable with T20 bypass plug.	K or H
5	Connect user-supplied ground to eMB-40M. See Grounding the Robot System on page 82.	n/a
5a	Connect user-supplied ground to robot. See Grounding the Robot System on page 82.	n/a
6	Connect 200-240 VAC to VAC Input on eMB-40M Interface Panel; secure with clamp.	T, U
7	Connect 24 VDC to DC Input on robot interface panel.	Q, R, S
8	Connect Ethernet cable from PC to eMB-40M.	Y
9	Connect eAIB/eMB - Force/Expio, Belt, RS-232 Cable to XBELTIO connector on eMB-40M.	V
10	Connect Belt Encoder to M12 Y-Adapter Cable to Belt branch of eAIB/eMB - Force/Expio, Belt, RS-232 Cable.	W, X
11	Connect Motor cable from robot to eMB-40MMotor Power connector	
12	Connect Encoder cable from robot to eMB-40MRobot Encoder connector	

6.2 System Cables, with Six Conveyor Encoders (SmartController EX)

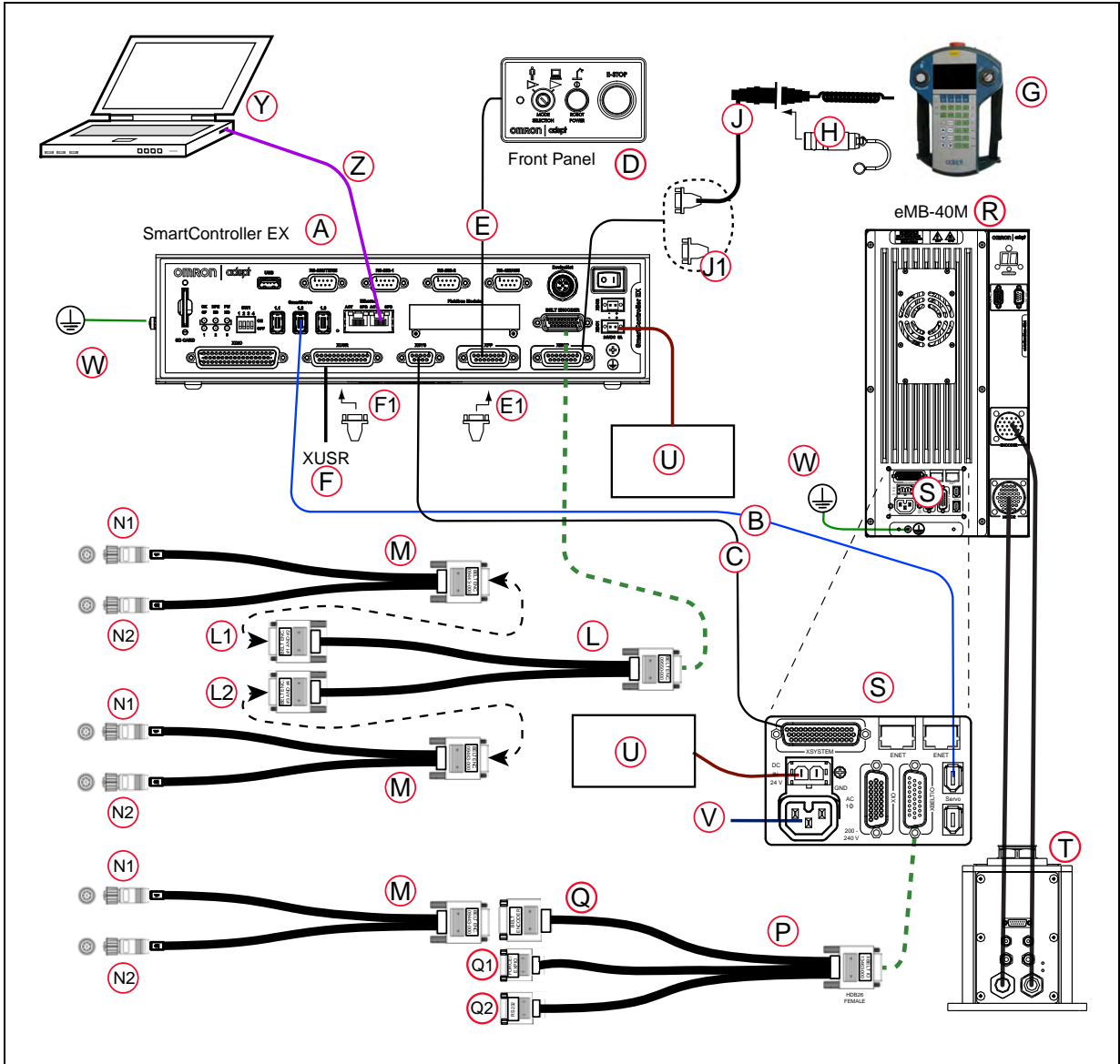

Figure 6-2. Conveyor Connections using both the eMB-40M and an Optional SmartController EX

In order to support four conveyor encoders from a SmartController EX, you need the Belt Encoder to DB15 Y-Adapter cable plugged into the controller's BELT ENCODER port, and one Belt Encoder to M12 Y-Adapter cable plugged into each of the two leads from that cable. See the preceding figure.

Table 6-3. System Cables with Six Conveyor Encoders (SmartController EX) Description

	Part	Part Number	Standard	Option	User-Supplied
A	SmartController EX	19300-000		X	
B	IEEE 1394 Cable	13632-045	X		
C	eAIB XSYS Cable	11585-000	X		
D	Front Panel	90356-10358		X	X
E	Front Panel Cable	10356-10500		X	X
E1	Front Panel Jumper Plug	04736-000	X		
	Either Front Panel or jumper plug must be used.				
F	XUSR	n/a	X		
F1	XUSR Jumper Plug	04736-000	X		
G	T20 Pendant Assembly Optional T20 Pendant Kit (10046-010) includes items G, H, and J.	10054-010		X	
H	T20 Pendant Bypass Plug	10048-000		X	
J	T20 Pendant Adapter Cable	10051-003		X	
J1	XMCP Jumper Plug	10052-000	X		
	Either T20 Pendant, T20 Bypass Plug, or XMCP Jumper Plug must be used				
L	Belt Encoder to DB15 Y-Adapter cable	09550-000		X	X
L1	Belt Encoder 1 and 2 Connector	n/a		X	
L2	Belt Encoder 3 and 4 Connector	n/a		X	
M	Belt Encoder to M12 Y-Adapter cable	09443-000		X	X
N1	to Belt Encoder n	n/a			
N2	to Belt Encoder n	n/a			

	Part	Part Number	Standard	Option	User-Supplied
	NOTE: If all six encoders are used, the bottom two become 5 and 6.				
P	eAIB/eMB - Force/Expio, Belt, RS232 cable	13463-000		X	X
Q	Belt Branch	n/a		X	
Q1	FORCE/EXPIO Connector	n/a		X	
Q2	RS232 Connector	n/a		X	
R	eMB-40M	19500-000	X		
S	eMB-40M Interface Panel	n/a	X		
T	Robot Interface Panel	n/a	X		
U	24 VDC, 6 A Power Supply, Cable	04120-000 04536-000		X	X
V	200-240 VAC, 10 A, single-phase, Cable	04118-000		X	X
W	Ground Wire	n/a			X
Y	PC running ACE	n/a			X
Z	Ethernet Cable	n/a			X

6.3 Optional Cables

XIO Breakout Cable

The XIO Breakout cable is for using the I/O on the eAIB. See XIO Breakout Cable on page 46. This cable provides access to 12 inputs and 8 outputs (5 m).

DB9 Splitter Cable

An optional Y cable attaches at the SmartController EX XSYS connector and splits it into two XSYS connectors. This is part number 00411-000. See the Single and Multiple Robot Configuration Guide.

eAIB/eMB - Force/EXPIO, Belt, RS232 Cable

The optional eAIB/eMB - Force/Expio, Belt, RS232 Cable split the eMB XBELTIO port into a belt encoder lead, an Intelligent Force Sensor or IO Blox lead, and an RS-232 lead. If the system has a SmartController EX, this is only needed for Intelligent Force Sensing.

Find the pin connection diagrams in the figures below (refer to Figure 6-2. for connector letter assignments).

SmartController EX Belt Encoder Y-Adapter Cable

The optional SmartController EX Belt Encoder Y-Adapter cable split the SmartController EX BELT ENCODER port into two belt encoder leads for encoders 1 and 2 and encoders 3 and 4.

Find the pin connection diagrams in the figures below (refer to Figure 6-2. for connector letter assignments).

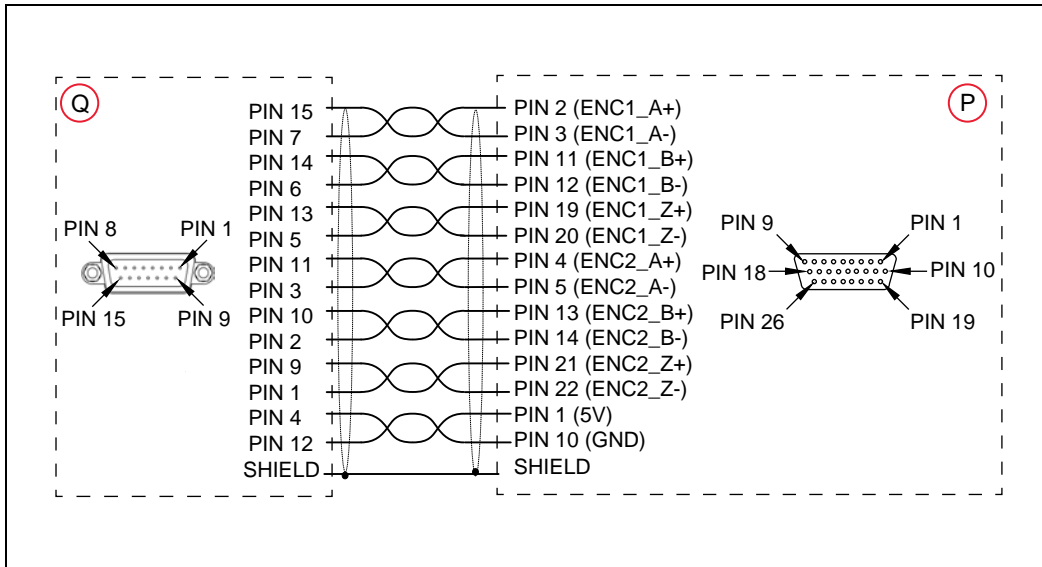

Figure 6-3. eAIB/eMB - Force/EXPIO, Belt, RS232 Cable Pinout - 2 Encoder Connections

NOTE: Cable shields connected to DSUB shell.

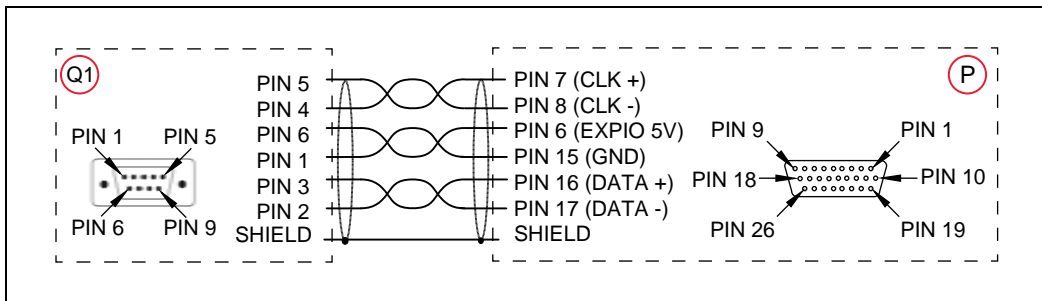

Figure 6-4. eAIB/eMB - Force/EXPIO, Belt, RS232 Cable Pinout - Force / EXPIO Connections

NOTE: Cable shields connected to DSUB shell.

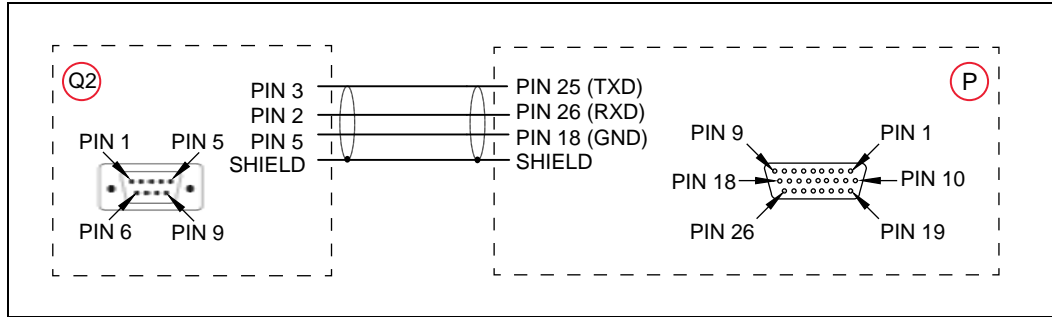

Figure 6-5. eAIB/eMB - Force/EXPIO, Belt, RS232 Cable Pinout - RS232 Connections

NOTE: Cable shields connected to DSUB shell.

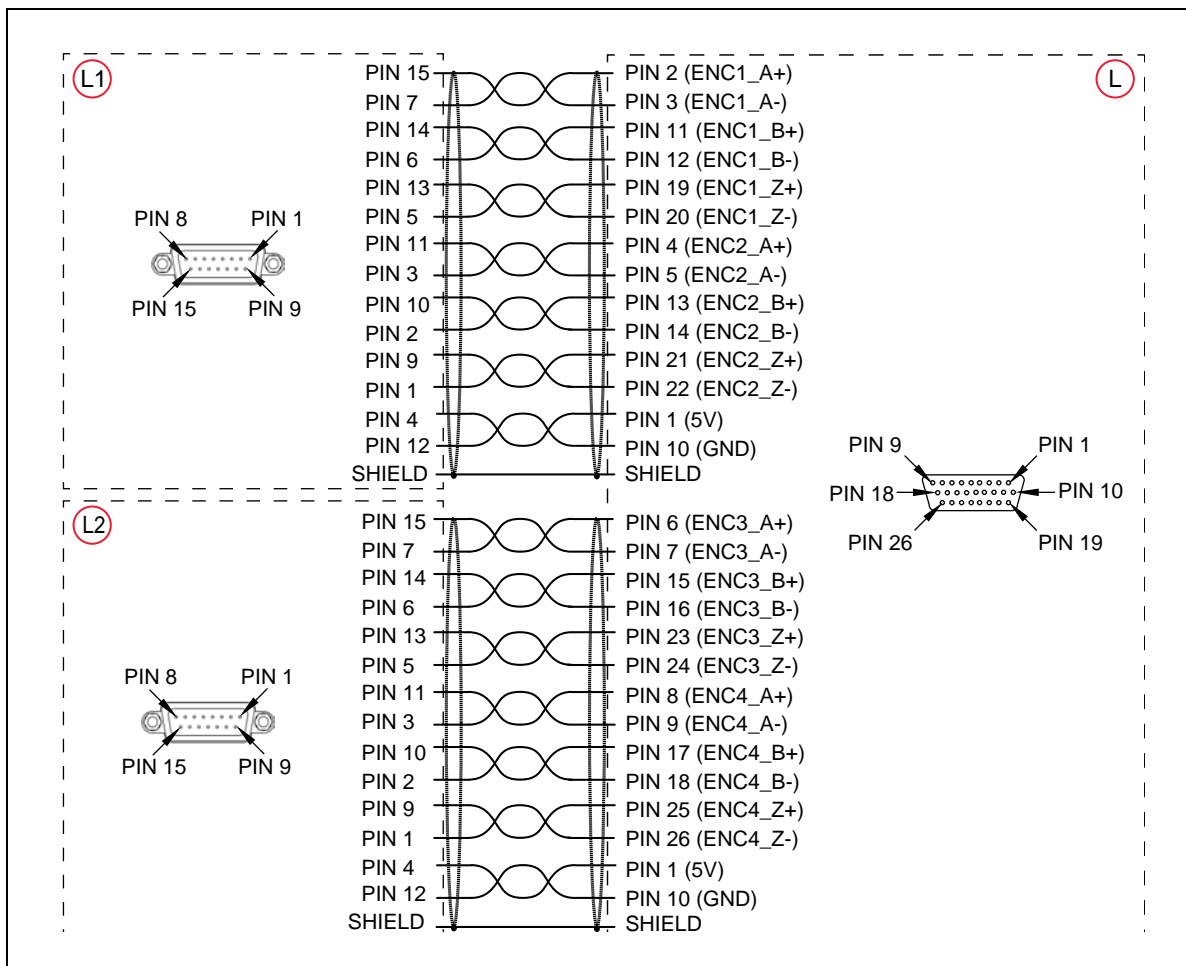

Figure 6-6. SmartController EX Belt Encoder Y-Adapter Cable Pinout

NOTE: Cable shields connected to DSUB shell.

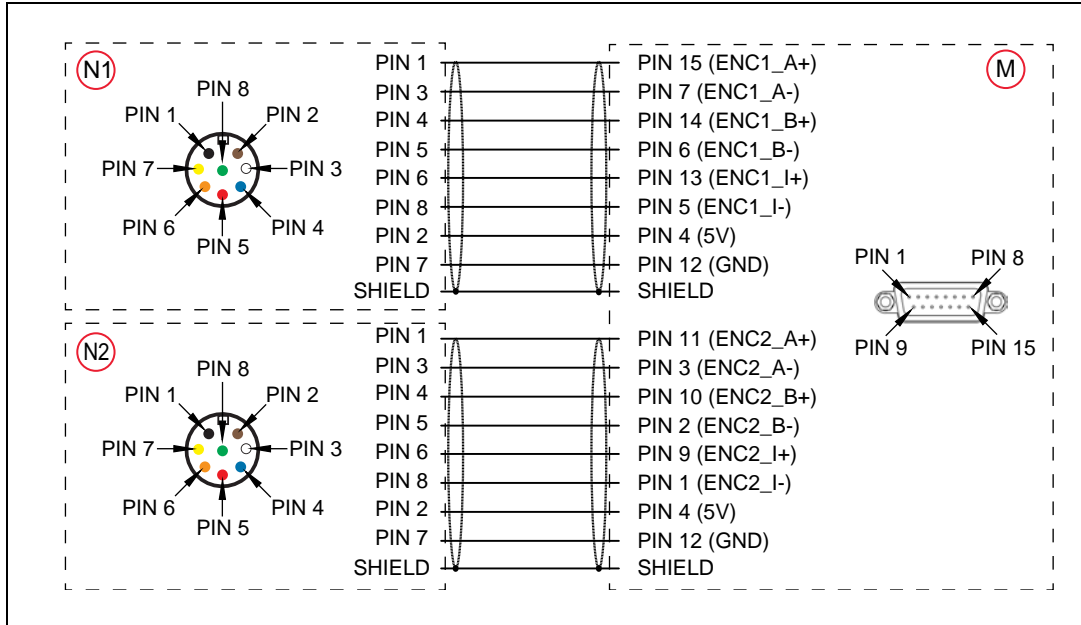

Figure 6-7. Belt Y Splitter Cable Pinout - 2 Encoder Connections

Chapter 7: Cable Installation, SmartController

7.1 System Cables, with SmartController

If you have an optional SmartController EX in the system, connect the Pendant, Front Panel, and XUSR connections to the SmartController EX.

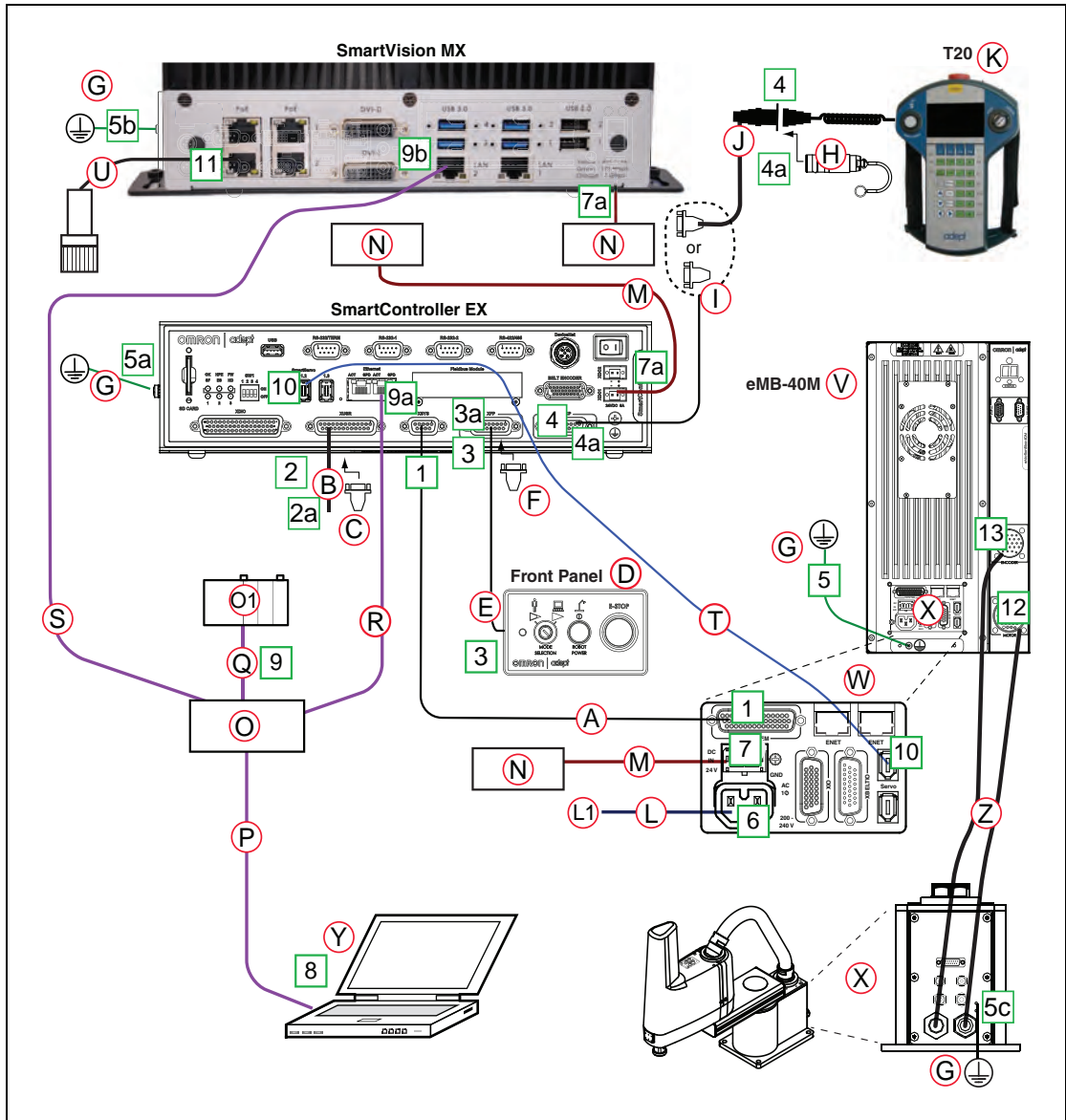

Figure 7-1. System Cable Diagram with SmartController (Cobra 450 Shown)

List of Cables and Parts

Part	Cable and Parts List	Part #	Standard	Option	User-Supplied
A	eAIB XSYS Cable, 4.6 m	11585-000	X		
B	User E-Stop, Safety Gate	n/a			X
C	XUSR Jumper Plug	04736-000	X		
D	Front Panel	90356-10358		X	X
E	Front Panel Cable, 3.05 m	10356-10500		X	X
F	Front Panel Jumper Plug	10053-000		X	
G	Ground Wire				X
H	T20 Pendant Bypass Plug	10048-000		X	
I	XMCP Jumper Plug	10052-000	X		
J	T20 Pendant Adapter Cable, 3.0 m	10051-003		X	
K	T20 Pendant Assembly Optional T20 Pendant Kit (10046-010) includes items H, J and K.	10054-010		X	
Items L, M, and N are available, as an option, in the power cable kit 04972-000.					
L	VAC Power Cable, 5 m	04118-000		X	X
L1	200-240 VAC, 10 A, single-phase User-supplied				X
M	24 VDC Power Cable, 5 m	04120-000		X	X
N	24 VDC, 6 A Power Supply	04536-000		X	X
O	Ethernet Switch	n/a			X
O1	PLC (optional)	n/a			X
P	Ethernet Cable from PC to switch	n/a			X
Q	Ethernet Cable from switch to PLC (optional)	n/a			X

Part	Cable and Parts List	Part #	Standard	Option	User-Supplied
R	Ethernet Cable to SmartController	n/a			X
S	Ethernet Cable to SmartVision MX	n/a			X
T	IEEE 1394 cable	13632-045	X		
U	Camera and cable	n/a		X	X
V	eMB-40M	19500-000	X		
W	eMB-40M Interface Panel		X		
X	Robot Interface Panel	19516-000	X		
Y	PC running PLC or ACE Programming Software				X
Z	Motor, Encoder Cable Harness	05701-200	X		

The XUSR, XMCP, and XFP jumpers intentionally bypass safety connections so you can test the system functionality during setup.



WARNING: PERSONAL INJURY/PROPERTY DAMAGE

Under no circumstances should you run a Cobra 450, 500, or 650 system, in production mode, with all three jumpers installed. This would leave the system with no E-Stops.

Cable Installation Overview

Step	Connection	Part
1	Connect eAIB XSYS cable to XSYSTEM on eMB-40M	A
2	Connect a user E-Stop or Muted Safety Gate to the XUSR connector or	B
2a	verify XUSR jumper plug is installed in XUSR connector.	C
3	Connect Front Panel cable to Front Panel and XFP connector or	D, E
3a	if no Front Panel, install FP jumper on XFP connector.	F
4	Connect Pendant adapter cable to XMCP connector or	J, K
4a	if no Pendant, install XMCP jumper or bypass plug.	G or H
5	Connect user-supplied ground to eMB-40M. See Grounding the Robot System on page 82.	n/a
5a	Connect user-supplied ground to SmartController EX. See SmartController EX user's guide for location.	n/a
5b	Connect user-supplied ground to SmartVision MX, if used. See SmartVision MX user's guide for location.	n/a

Step	Connection	Part
5c	Connect user-supplied ground to robot. See Grounding the Robot System on page 82.	n/a
6	Connect 200-240 VAC to VAC Input on eMB-40M; secure with clamp.	L
7	Connect 24 VDC to DC Input on eMB-40M.	N,M
7a	Connect 24 VDC to SmartController EX and SmartVision MX, if used.	N,M
8	Connect Ethernet cable from PC to switch	O, P, Y
9	Connect Ethernet cable from PLC, if used, to switch.	O, O1, Q
9a	Connect Ethernet cable from switch to SmartController EX, if used.	O, R
9b	Connect Ethernet cable from switch to SmartVision MX, if used.	O, S
10	Connect IEEE 1394 cable between SmartController EX and eMB-40M SmartServo	T
11	Connect optional camera and cable to SmartVision MX, if used.	U
12	Connect Motor cable from robot to eMB-40M Motor connector	Z
13	Connect Encoder cable from robot to eMB-40M Encoder connector	Z

NOTE: The eMB-40M has connectors for the Motor and Encoder cables that are connected to the robot interface panel at the factory. You will need to connect the free ends of these to the eMB-40M.

NOTE: If you don't purchase the optional Front Panel, you must replace its functionality with equivalent circuits. Refer to the schematics in Installing User-Supplied Safety Equipment on page 88.

Optional Cables

NOTE: The following optional cables are not covered in the steps in the preceding table.

Part Description	Notes
XIO Breakout Cable , 12 inputs/ 8 outputs, 5 m	Refer to Using Digital I/O on eMB-40M XIO Connector on page 39.
Y Cable , for XSYS cable connections to multiple robots (for SmartController)	Available as option with SmartController EX. P/N 00411-000.
eAIB/eMB Force/Expio, Belt, RS232 Three-headed Cable	P/N 13463-000
Belt Encoder to DB15 Y-Adapter	P/N 09550-000

Part Description	Notes
Cable	
Belt Encoder to M12 Y-Adapter Cable	P/N 09443-000
Power Cable Kit - contains 24 VDC and VAC power cables and 150 W Power Supply (90-264 VAC Input, 50-60 Hz)	P/N 90565-010

The XIO Breakout cable is for using the I/O on the eMB-40M. See XIO Breakout Cable on page 46.

The Y cable attaches at the SmartController EX XSYS connector, and splits it into two XSYS connectors. This is part number 00411-000. See the *Single and Multiple Robot Configuration Guide*.

The optional eAIB XBELT IO Adapter cable splits the eAIB XBELTIO port into a belt encoder lead, an Intelligent Force Sensing or IO Blox lead, and an RS-232 lead. If the system has a SmartController, this is only needed for Intelligent Force Sensing.

7.2 Installing the SmartController EX

Refer to the *SmartController EX User's Guide* for complete information on installing the SmartController EX. This list summarizes the main steps.

1. Mount the SmartController.
2. Install your front panel. The front panel must be outside of the work area, but near the work area.
3. Connect the front panel to the SmartController.
4. Connect the optional pendant (if included) to the SmartController.
5. Connect user-supplied 24 VDC power to the controller. Instructions for creating the cable, and power specifications, are covered in the *SmartController EX User's Guide*.
6. Install a user-supplied ground wire between the SmartController and ground.
7. Install the ACE software on the user-supplied PC (see the following section).

7.3 Installing the ACE Software

The ACE software is installed from the documentation and ACE software USB drive.

1. Insert the drive into your PC.
If Autoplay is enabled, the software menu is displayed. If Autoplay is disabled, you will need to manually start the software.
2. Especially if you are upgrading your ACE software installation: from the ACE software menu, click Read Important Information.
3. From the ACE software menu, select:

Install the ACE Software

The ACE Setup wizard opens.

4. Follow the online instructions as you step through the installation process.
5. When the installation is complete, click Finish.
6. After closing the ACE Setup wizard, click Exit on the software menu to close the menu.

NOTE: You will have to restart the PC after installing ACE software.

7.4 Connecting the PC to the SmartController

The SmartController motion controller must be connected to a user-supplied PC or the SmartVision MX vision processor for setup, control, and programming.

- Connect an Ethernet crossover cable between the PC and the SmartController motion controller
- or
- Use two standard Ethernet cables with a network hub or switch in place of the Ethernet crossover cable.

NOTE: Do not use an Ethernet crossover cable with a network hub or switch.

For more details, refer to the *ACE User's Guide*.

7.5 Cable Connections to Robot

There are two cables between the robot and the eMB-40M: the Motor Power cable and the Robot Encoder cable, as shown in the following figure.

These cables have a minimum bending radius as follows:

- Motor Power Cable: 115 mm
- Encoder Cable: 112 mm

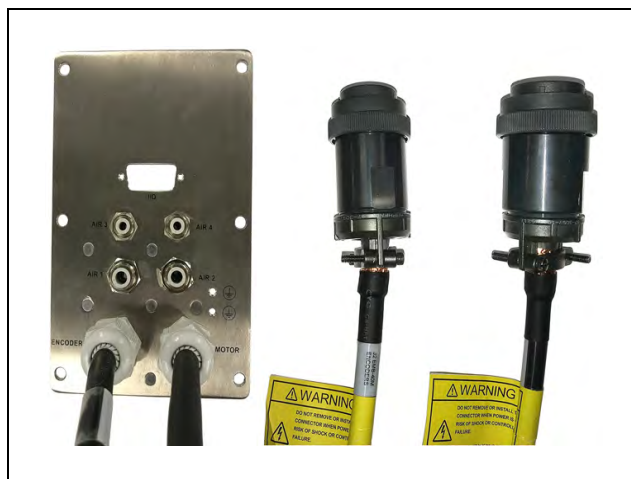

Figure 7-2. Cables in Interface Panel, Loose eMB Ends

One end of the cables is connected to the robot interface at the factory.

1. Connect the other end of the Motor Power cable to the Motor Power connector on the eMB-40M. Tighten the screws securely.
2. Connect the other end of the Robot Encoder cable to the Robot Encoder connector on the eMB-40M. Tighten the screws securely.



CAUTION: Verify that all connectors are fully-inserted and screwed down. Failure to do this could cause unexpected robot motion. Also, a connector could get pulled out or dislodged unexpectedly.

7.6 Cable Connections from eMB-40M to SmartController

1. Locate the IEEE 1394 cable (length 4.5 m) and the eAIB XSYS cable (length 4.5 m). They are shipped in the cable/accessories box.
2. Install one end of the IEEE 1394 cable into the SmartServo connector on the SmartController, and install the other end into a SmartServo connector on the eMB-40M interface panel, as shown in Figure 7-1.
3. Install the eAIB XSYS cable between the XSYS connector on the SmartController and the eMB-40M XSYSTEM connector, and tighten the latching screws.

NOTE: The IEEE 1394 and XSYS/eAIB XSYS cables should be routed away from AC power and robot interconnect cables.

Chapter 8: AC/DC Power and Grounds

8.1 Cable List

Table 8-1. Cables and Parts List

Cable Description	Notes
Power Cable Kit - contains 24 VDC and VAC power cables - P/N 04972-000	Available as option

8.2 Connecting 24 VDC Power to eMB-40M

This section covers power to the eMB-40M. The power supply requirements for a SmartController EX or a SmartVision MX are similar, with each needing its own power supply, or else sharing a larger-capacity power supply.

Specifications for 24 VDC Power

Table 8-2. Specifications for 24 VDC User-Supplied Power Supply

Customer-Supplied Power Supply	24 VDC ($\pm 10\%$), 150 W (6 A) ($21.6\text{ V} < V_{in} < 26.4\text{ V}$)
Circuit Protection ¹	Output must be less than 300 W peak or 8 Amp in-line fuse
Power Cabling	1.5 – 1.85 mm ² (16-14 AWG)
Shield Termination	Cable shield connected to frame ground on power supply and ground point on eMB-40M, as shown in Figure 8-1.
¹ User-supplied 24 VDC power supply must incorporate overload protection to limit peak power to less than 300 W, or 8 A in-line fuse protection must be added to the 24 V power source.	

The power requirements for the user-supplied power supply will vary depending on the configuration of the robot and connected devices. We recommend a 24 V, 6 A power supply to allow for startup current draw and load from connected user devices, such as digital I/O loads.



CAUTION: Make sure you select a 24 VDC power supply that meets the specifications in the preceding table. Using an underrated supply can cause system problems and prevent your equipment from operating correctly.



Table 8-3. Recommended 24 VDC Power Supplies

Vendor Name	Model	Ratings	Mount
OMRON	S8FS-G15024C	24 VDC, 6.5 A, 150 W	Front Mount
OMRON	S8FS-G15024CD	24 VDC, 6.5 A, 150 W	DIN-Rail Mount
OMRON	S8VK-S24024	24 VDC, 10 A, 240 W	DIN-Rail Mount

Details for 24 VDC Mating Connector

The 24 VDC mating connector and two pins are supplied with each system. They are shipped in the cable/accessories box.

Table 8-4. 24 VDC Mating Connector Specs

Connector Details  A: Ground (pin 1, labeled on under side) B : +24 VDC	Connector receptacle, 2-position, type: Molex Saber, 18 A, 2-Pin
	Molex P/N 44441-2002
	Digi-Key P/N WM18463-ND
Pin Details 	Molex connector crimp terminal, female, 14-18 AWG
	Molex P/N 43375-0001
	Digi-Key P/N WM18493-ND

NOTE: The 24 VDC cable is not supplied with the system, but is available in the optional Power Cable kit. See Cables and Parts List on page 75.

Procedure for Creating 24 VDC Cable

1. Locate the connector and pins from the preceding table.
2. Use shielded two-conductor cable with 14-16 AWG wire to create the 24 VDC cable. Select the wire length to safely reach from the user-supplied 24 VDC power supply to the eMB-40M base.

NOTE: You also must create a separate 24 VDC cable for the SmartController EX, if you are using one. That cable uses a different style of connector. See the *SmartController EX User's Guide*.

3. Crimp the pins onto the wires according to the pin manufacturer's instructions.
4. Insert the pins into the connector. Confirm that the +24 V and ground wires are in the correct terminals in the plug.
5. Install a user-supplied ring lug (for an M3 screw) on the shield at the eMB-40M end of the cable.
6. Prepare the opposite end of the cable for connection to the user-supplied 24 VDC power supply, including a terminal to attach the cable shield to frame ground.

Installing the 24 VDC Cable

Do not turn on the 24 VDC power until instructed to do so in the next chapter.

1. Connect one end of the shielded 24 VDC cable to your user-supplied 24 VDC power supply. See the following figure. The cable shield should be connected to frame ground on the power supply. Do not turn on the 24 VDC power until instructed to do so in System Operation on page 99.
2. Plug the mating connector end of the 24 VDC cable into the 24 VDC connector on the interface panel on the back of the eMB-40M. The cable shield should be connected to the ground point on the interface panel.

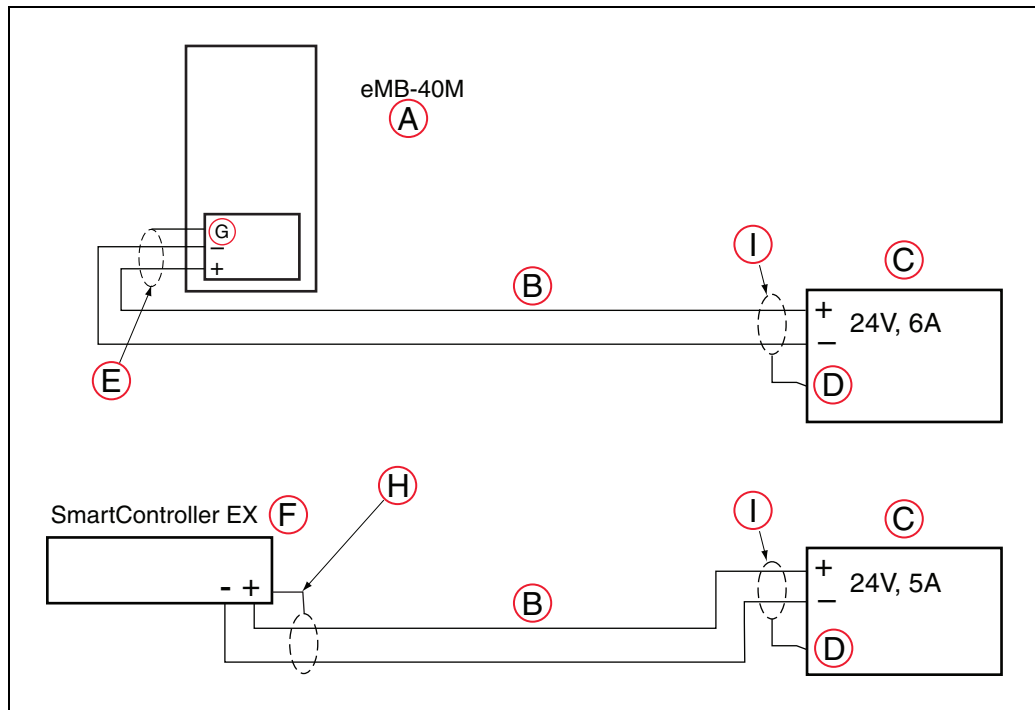

Figure 8-1. User-Supplied 24 VDC Cable, with Optional SmartController EX

Key	Meaning	Key	Meaning
A	eMB-40M Servo Controller	F	SmartController EX Option
B	User-Supplied Shielded Power Cable	G	Ground

Key	Meaning	Key	Meaning
C	User-Supplied Power Supply 24 VDC	H	Attach shield from user-supplied cable to side of controller using star washer and M3 x 6 screw.
D	Attach shield from user supplied cables to frame ground on power supply	I	Attach shield from user-supplied cables to frame ground on power supply.
E	Attach shield from user-supplied cable to ground screw on eMB-40M Interface Panel.		

NOTE: We recommend that DC power be delivered over shielded cables, with the shield connected to frame ground at the power supply, and to the ground points shown. The length of wire from the cable shield to the grounds should be less than 50 mm.

8.3 Connecting 200-240 VAC Power



WARNING: ELECTROCUTION RISK

Ensure compliance with all local and national safety and electrical codes for the installation and operation of the robot system.



WARNING: ELECTROCUTION RISK

Provide appropriately-sized Branch Circuit Protection and Lockout / Tagout Capability in accordance with the National Electrical Code and any local codes.

Specifications for AC Power

Table 8-5. Specifications for 200/240 VAC User-Supplied Power Supply

Auto-Ranging Nominal Voltage Ranges	Minimum Operating Voltage ¹	Maximum Operating Voltage	Frequency/ Phasing	Recommended External Circuit Breaker, User-Supplied
200 to 240 V	180 V	264 V	50/60 Hz, 1-phase	10 Amps

¹Specifications are established at nominal line voltage. Low line voltage can affect robot performance.

NOTE: The robot system is intended to be installed as a piece of equipment in a permanently-installed system.

**WARNING: ELECTROCUTION/PROPERTY DAMAGE**

Cobra 450, 500, and 650 robot systems require an isolating transformer for connection to mains systems that are asymmetrical or use an isolated (impedant) neutral. Many parts of Europe use an impedant neutral.

**DANGER: ELECTROCUTION RISK**

AC power installation must be performed by a skilled and instructed person—see the *Robot Safety Guide*. During installation, unauthorized third parties must be prevented from turning on power through the use of fail-safe lockout measures.

Failure to use appropriate power (less than or more than the rated voltage range of 200 - 240 VAC) can lead to malfunction or failures of the robot or hazardous situations.

Facility Overvoltage Protection

The user must protect the robot system from excessive overvoltages and voltage spikes. If the country of installation requires a CE-certified installation, or compliance with IEC 1131-2, the following information may be helpful: IEC 1131-2 requires that the installation must ensure that Category II overvoltages (i.e., line spikes not directly due to lightning strikes) are not exceeded. Transient overvoltages at the point of connection to the power source shall be controlled not to exceed overvoltage Category II, i.e., not higher than the impulse voltage corresponding to the rated voltage for the basic insulation. The user-supplied equipment or transient suppressor shall be capable of absorbing the energy in the transient.

In the industrial environment, nonperiodic over-voltage peaks may appear on mains power supply lines as a result of power interruptions to high-energy equipment (such as a blown fuse on one branch in a 3-phase system). This will cause high-current pulses at relatively low voltage levels. The user shall take the necessary steps to prevent damage to the robot system (such as by interposing a transformer). See IEC 1131-4 for additional information.

AC Power Diagrams

Figure 8-2. Typical AC Power Installation with Single-Phase Supply

Key	Meaning	Key	Meaning
B	User-Supplied AC Power Cable	L	Line
E	Earth Ground	N	Neutral
F1	Fuse, 10A		
NOTE: F1 is user-supplied, must be slow-blow.			

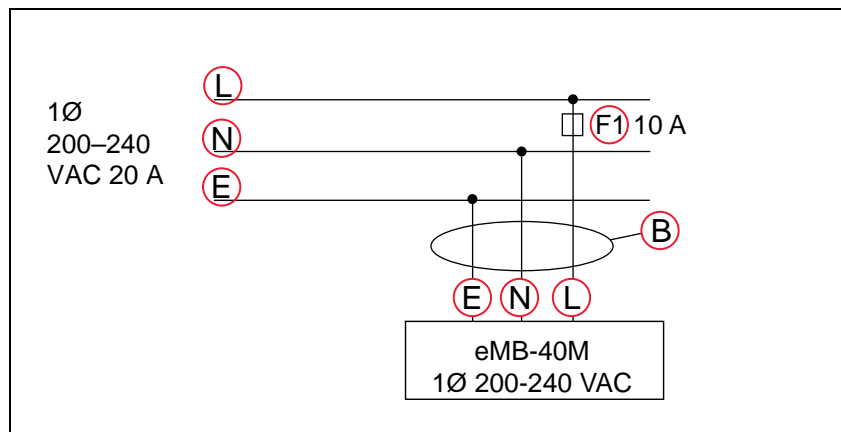
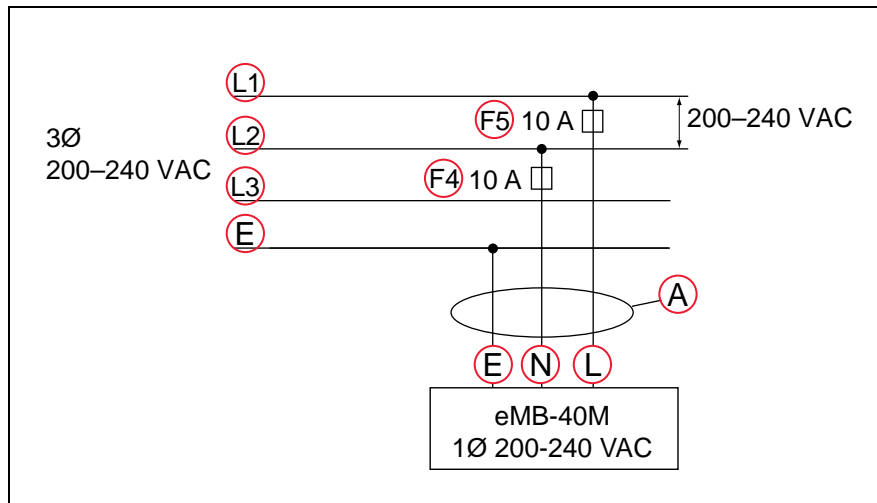

Figure 8-3. Single-Phase Load across L1 and L2 of a Three-Phase Supply

Key	Meaning	Key	Meaning
A	User-Supplied AC Power Cable	L1	Line 1
E	Earth Ground	L2	Line 2
F4	Fuse, 10A	L3	Line 3
F5	Fuse, 10A	N	Neutral
L	Line 1		
NOTE: F1 is user-supplied, must be slow-blow.			

Details for AC Mating Connector

The AC mating connector is supplied with each system. It is shipped in the cable/accessories box. The supplied plug is internally labeled for the AC power connections (L, E, N).

Table 8-6. AC Mating Connector Details

AC Connector details	AC in-line power plug, straight, female, screw terminal, 10 A, 250 VAC
----------------------	--

	
	Qualtek P/N 709-00/00
	Digi-Key P/N Q217-ND

NOTE: The AC power cable is not supplied with the system, but is available in the optional Power Cable kit. See Table 8-1.

Procedure for Creating 200 to 240 VAC Cable

1. Locate the AC mating connector shown in the preceding table.
2. Open the connector by unscrewing the screw on the shell and removing the cover.
3. Loosen the two screws on the cable clamp. See the following figure for details.
4. Use 18 AWG wire to create the AC power cable. Select the wire length to safely reach from the user-supplied AC power source to the eMB-40M base.
5. Strip 18 to 24 mm of insulation from each of the three wires.
6. Insert the wires into the connector through the removable bushing.
7. Connect each wire to the correct terminal screw, and tighten the screw firmly.
The pins are labeled inside the body.
8. Tighten the screws on the cable clamp.
9. Replace the cover and tighten the screw to seal the connector.
10. Prepare the opposite end of the cable for connection to the facility AC power source.

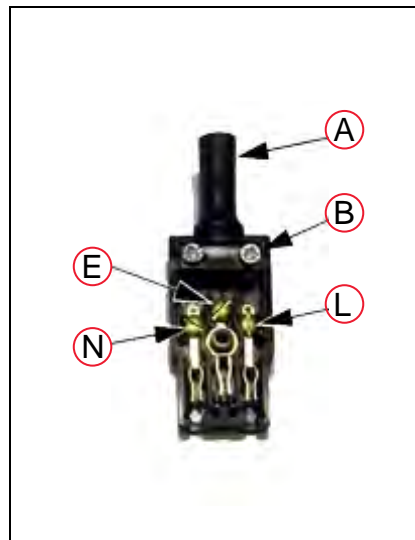

Figure 8-4. AC Power Mating Connector

Key	Meaning	Key	Meaning
A	Removable Bushing	E	Earth
B	Cable Clamp	N	Neutral
L	Line		

Installing AC Power Cable to eMB-40M

1. Connect the unterminated end of the AC power cable to your facility AC power source. See the two preceding figures for details. Do not turn on AC power at this time.
2. Plug the AC connector into the AC power connector on the interface panel on the eMB-40M.
3. Secure the AC connector with the locking latch.

8.4 Grounding the Robot System

Proper grounding is essential for safe and reliable robot operation. Follow these recommendations to properly ground your robot system.

The primary grounding for the Cobra 450, 500, and 650 is through the eMB-40M. Two secondary user ground holes are available on the robot interface panel. Refer to the figure (A) Ground Holes on Robot Interface Panel on page 84.

NOTE: The resistance of a ground conductor must be $\leq 10 \Omega$.

Ground Point on eMB-40M

The user can install a ground wire at the eMB-40M chassis. Use the hole below the eMB-40M interface panel - see the following figure. The user should provide a ground wire and use the provided M3 screw and external tooth lock washer to connect to earth ground. Make sure to tighten the screw on the ground wire to create a proper ground connection. Two threaded holes are provided to attach optional user-supplied strain relief.

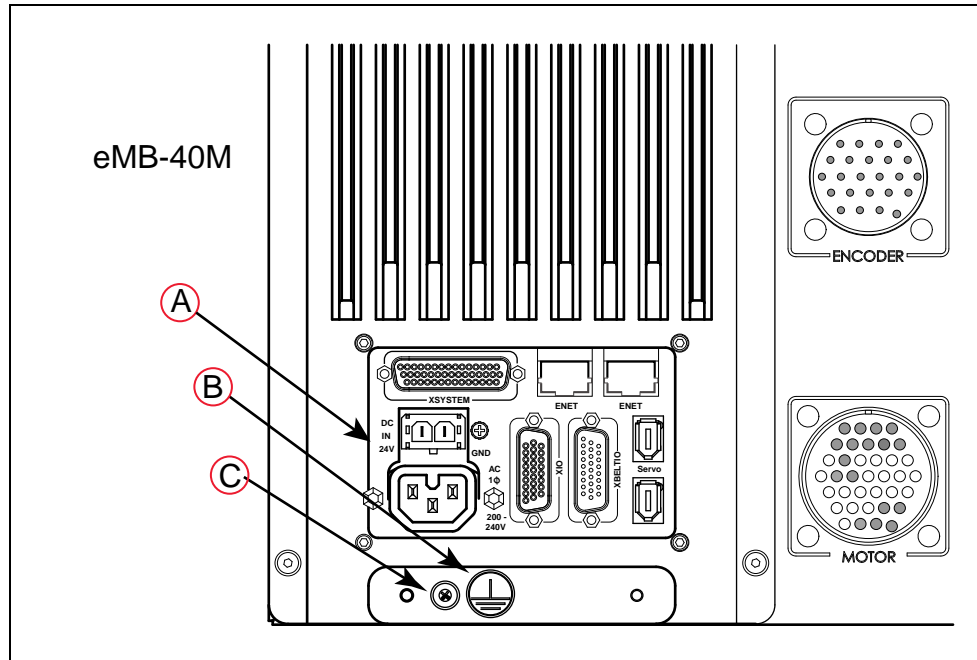

Figure 8-5. Earth Ground Location

Key	Meaning
A	eMB-40M Interface Panel
B	Ground Label
C	Ground Screw

User Ground Holes on Robot Interface Panel

The user can install a ground wire at the robot interface panel to ground the robot. The ground holes are shown in the following figure. The user is responsible for supplying the ground wire to connect to earth ground.

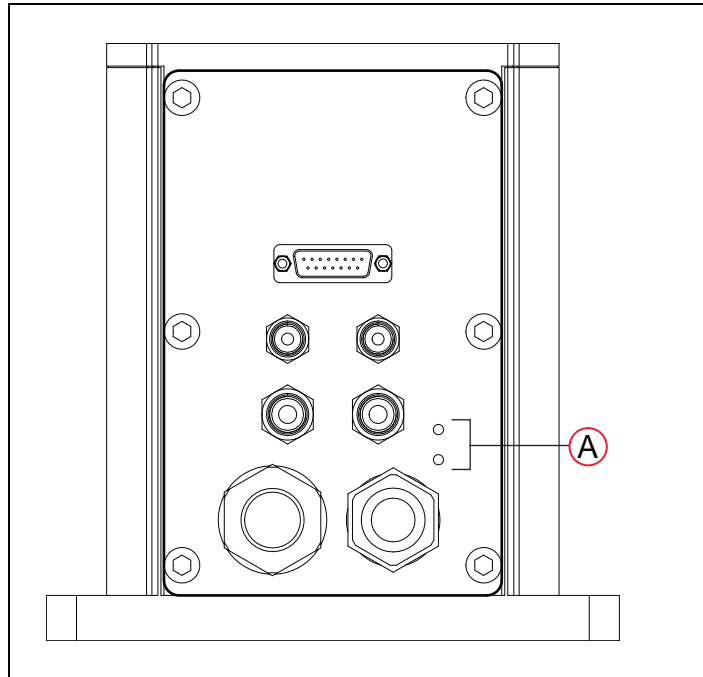

Figure 8-6. (A) Ground Holes on Robot Interface Panel

Robot-Mounted Equipment Grounding

The Cobra 450, 500, and 650 Joint 3 shaft and tool flange are not reliably grounded to the robot base. If hazardous voltages are present at any user-supplied end-of-arm tooling, you must install a ground connection from that tooling to the ground point on the robot base. Hazardous voltages can be considered anything in excess of 30 VAC (42.4 VAC peak) or 60 VDC.



WARNING: ELECTROCUTION RISK

Failing to ground robot-mounted equipment or tooling that uses hazardous voltages could lead to injury or death of a person touching the end-effector when an electrical fault condition exists.

Chapter 9: User Connections

9.1 User Connections on Robot

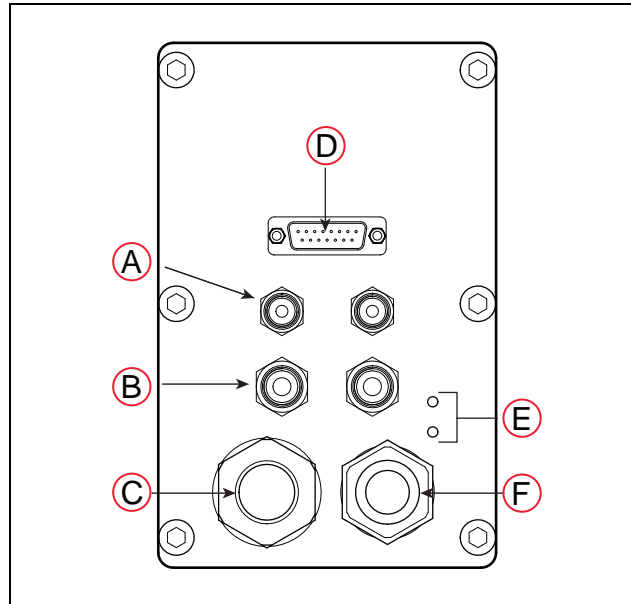

Figure 9-1. Robot Interface Panel

Key	Meaning	Key	Meaning
A	4 mm Air	D	15-pin User I/O
B	6 mm Air	E	User Grounds
C	Encoder Cable	F	Motor Cable

User Air Lines

There are four user air line connectors on the robot interface panel on the back of the robot. See the preceding figure. The four air lines run through the robot up to another set of four matching connectors on the top of Joint 2. The normal operating pressure for the air source is from 0.4 to 0.5 MPa (58 to 72.5 psi). The Cobra 450, 500, and 650 are *not* equipped with solenoid valves as standard equipment.

User Electrical Lines

A D-sub 15 connector on the robot interface panel connects to 15 user electrical lines that run inside the robot to another D-sub 15 connector on the top of Joint 2, as shown in the following figure. The maximum current per line is 1 Amp.

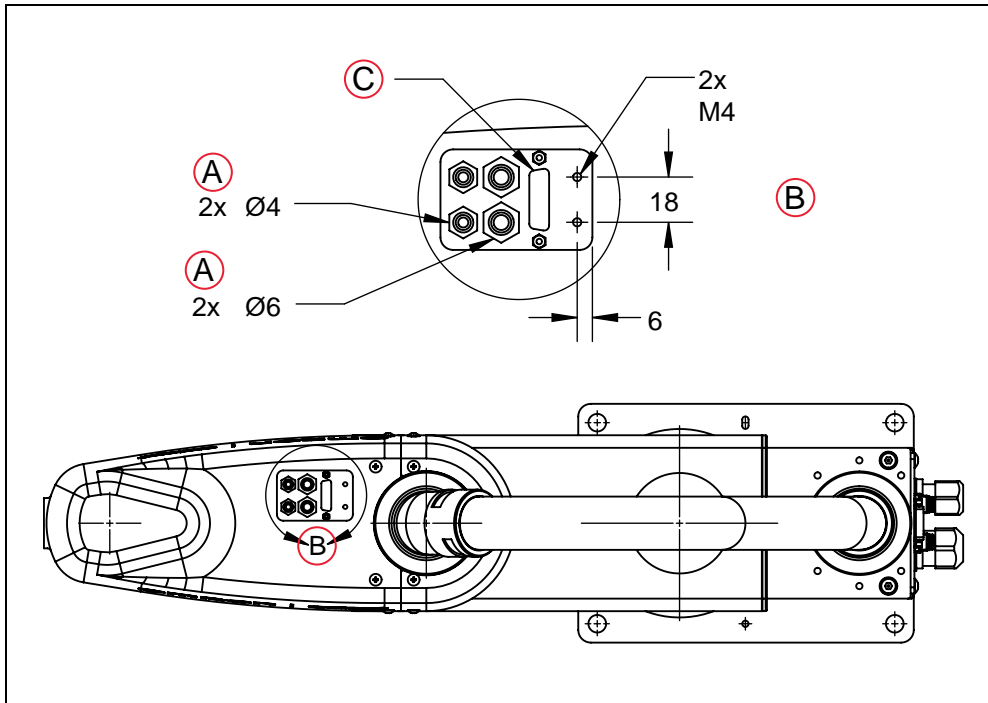

Figure 9-2. Joint 2 Air and Electrical Connector (Units in mm)

Key	Meaning
A	Air
B	Detail View, Scale 1:3
C	I/O D-Sub, 15 Pin

Tool Flange

IMPORTANT: Removing or even loosening the tool flange will require the robot to be recalibrated. If you do not have the calibration kit, do not loosen or remove the tool flange.

The tool flange can be removed and reinstalled. If the flange is removed, the system must be recalibrated.

Removing the Flange

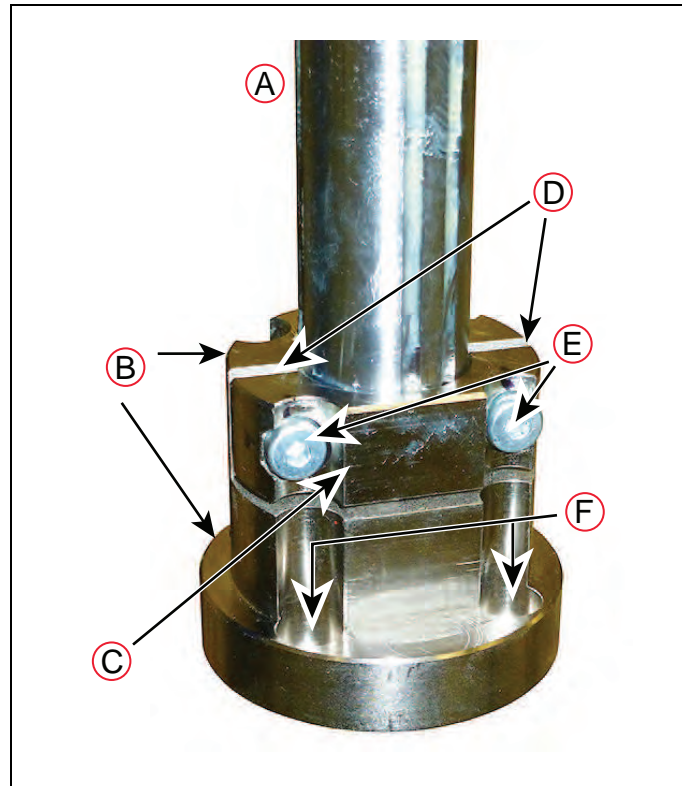

Figure 9-3. Tool Flange on Joint 3 Shaft

Key	Meaning	Key	Meaning
A	Tool Flange Shaft	D	Gaps Between Body and Clamp
B	Tool Flange Body	E	Clamp Screws
C	Tool Flange Clamp	F	Flange Thru Holes

There is a clamp on the flange that holds the flange on the Joint 3 shaft. Follow the procedures below to remove and replace the flange assembly.

1. Turn off high power and system power to the robot.
2. Remove any attached end-effectors or other tooling from the flange.

- Loosen the two M3 socket-head cap screws.
These go through the clamp that holds the tool flange to the shaft.
- Slide the flange down until it is off the shaft.

Reinstalling the Flange

- Slide the flange up on the shaft until the flange touches the bottom of the shaft.
- Support the flange while using a 2.5 mm hex driver to tighten the two M3 socket head cap screws. Tighten the two screws equally, so the gaps between the clamp and the tool flange body are the same width on both sides.

Mounting Options for User Connections

There are four M5 holes on the front end of J2 that can be used for mounting a camera or supporting air or electric lines. See the following figure.

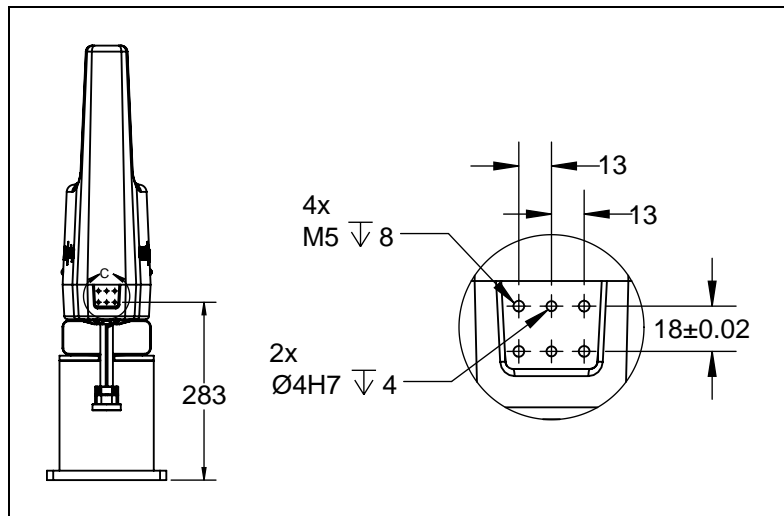

Figure 9-4. Camera or other option Support Holes, Front of J2 (Units in mm)

9.2 Installing User-Supplied Safety Equipment

The user is responsible for installing safety barriers to protect personnel from coming in contact with the robot unintentionally. Depending on the design of the workcell, you can use safety gates, light curtains, and emergency stop devices create a safe environment. Read the *Robot Safety Guide* for a discussion of safety issues.

NOTE: For a system with a SmartController EX, the XUSR, XFP, and XMCP connections all go to the SmartController EX rather than through the XSYSTEM to the eMB-40M. Refer to System Cables, with SmartController on page 67.

The user-supplied safety and power-control equipment connects to the system through the XUSR and XFP connectors on the eMB-40M XSYSTEM cable. The XUSR connector (25-pin) and XFP (15-pin) connector are both female D-sub connectors. Refer to the following table for the XUSR pin-out descriptions. Table 9-2. for the XFP pin-out descriptions. See the figure System Cables (without SmartController EX option) on page 51 for the XUSR wiring diagram.

Table 9-1. Contacts Provided by the XUSR Connector

Pin Pairs	Description	Comments
Voltage-Free Contacts Provided by Customer		
1, 14	User E-Stop CH 1 (mushroom push-button, safety gates, etc.)	NC contacts, Shorted if NOT Used
2, 15	User E-Stop CH 2 (same as pins 1, 14)	NC contacts, Shorted if NOT Used
3, 16	Line E-Stop (used for other robot or assembly line E-Stop inter-connection. Does not affect E-Stop indication (pins 7, 20))	NC contacts, Shorted if NOT Used
4, 17	Line E-Stop (same as pins 3, 16)	NC contacts, Shorted if NOT Used
5, 18	Muted Safety Gate CH 1 (causes E-Stop in Automatic mode only)	NC contacts, Shorted if NOT Used
6, 19	Muted Safety Gate CH 2 (same as pins 5, 18)	NC contacts, Shorted if NOT Used
Voltage-Free Contacts provided by Cobra 450, 500, and 650		
7, 20	E-Stop indication CH 1	Contacts are closed when Front Panel, pendant, and customer E-Stops are <i>not</i> tripped
8, 21	E-Stop indication CH 2 (same as pins 7, 20)	Contacts are closed when Front Panel, pendant, and customer E-Stops are <i>not</i> tripped
9, 22	Manual/Automatic indication CH 1	Contacts are closed in Automatic mode
10, 23	Manual/Automatic indication CH 2	Contacts are closed in Automatic mode
11, 12, 13, 24, 25	No connection	

Table 9-2. Contacts Provided by the XFP Connector

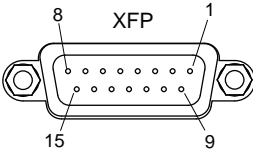
Pin Pairs	Description	Requirements for User-Supplied Front Panel
Voltage-Free Contacts Provided by Customer		
1, 9	Front Panel E-Stop CH 1	User must supply NC contacts
2, 10	Front Panel E-Stop CH 2	User must supply NC contacts
3, 11	Remote Manual/Automatic switch CH 1. Manual = Open Automatic = Closed	Optional - jumper closed for Auto Mode-only operation
4, 12	Remote Manual/Automatic switch CH 2. Manual = Open Automatic = Closed	Optional - jumper closed for Auto Mode-only operation
6, 14	Remote High Power on/off momentary push-button	User must supply momentary push-button to enable High Power to system
Non-voltage-Free Contacts		
5, 13	System-Supplied 5 VDC and GND for High Power On/Off Switch Lamp	User must supply lamp, or use 1 W, 47 Ohm resistor - system will not operate if not present
7, 15 ^a	Controller system 5 V power on LED, 5 V, 20 mA	Optional - indicator only
8	No connection	
 <p>The diagram shows a rectangular XFP connector with two mounting lugs on the sides. It features a row of 15 pins. Pin 1 is at the top right, pin 8 is at the top left, pin 9 is at the bottom right, and pin 15 is at the bottom left. The label 'XFP' is centered above the pin row.</p>		
See Figure 9-6. for a schematic diagram of the Front Panel.		
^a Users must exercise caution to avoid inadvertently connecting 24 V signals to these pins, because this will damage the electronics.		

NOTE: The system was evaluated by Underwriters Laboratory with an Omron-Adept-supplied Front Panel. Using other equipment in place of the Front Panel could void UL compliance.

Table 9-3. Remote Pendant Connections on the XMCP Connector

Pin XMCP (15-Pin D-Sub)	Description
1, 9	Pendant E-Stop Push-button CH 1
2, 10	Pendant E-Stop Push-button CH 2
3, 11	Pendant Enable CH 1 (Hold-to-run)
4, 12	Pendant Enable CH 2 (Hold-to-run)
13	Serial GND/Logic GND
7	Pendant TXD: "eV+ to Pendant TXD"
8	Pendant RXD: "eV+ to Pendant RXD"
14	No connection
15	No connection
Shield	Shield GND
6	24 V
5	No connection

9.2 Installing User-Supplied Safety Equipment

The following figure shows an E-Stop diagram for the system. See Emergency Stop Circuits on page 94 for a description of the functionality of this circuit.

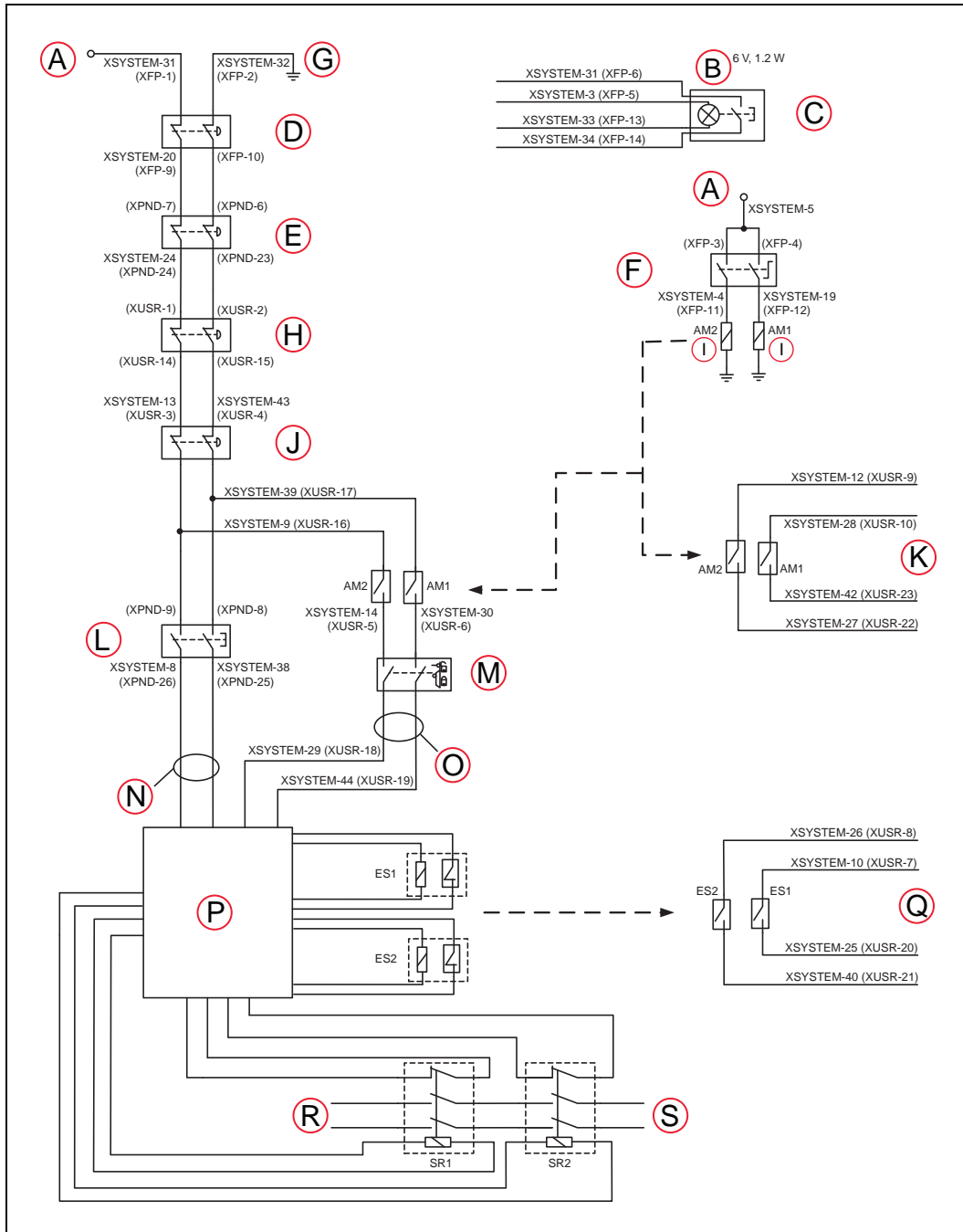

Figure 9-5. E-Stop Circuit on XUSR and XFP Connectors

Key	Meaning	Key	Meaning
A	ESTOP 24 V Source	K	Auto/Manual Output
B	Bulb, 6 V, 1.2 W	L	T20 Pendant Enable
C	Front Panel High Power ON/OFF	M	Muted Safety Gate - Active in Auto mode only (Jumper closed when not used)
D	Front Panel ESTOP Pushbutton	N	Manual Mode Path
E	T20 ESTOP Push-button	O	Auto Mode Path
F	Front Panel Auto/Manual Key-switch	P	Force-Guided Relay Cycle Check Control Circuit
G	ESTOP Ground	Q	User ESTOP Output
H	User E-Stop and Gate Interlock NOTE: Jumper closed when not used, MUST open both channels independently if used.		
I	Coil	R	Single-Phase AC Input, 200-240 VAC
J	LINE E-Stop (External User E-Stop System)	S	High Power to Amplifiers (Internal Connections)

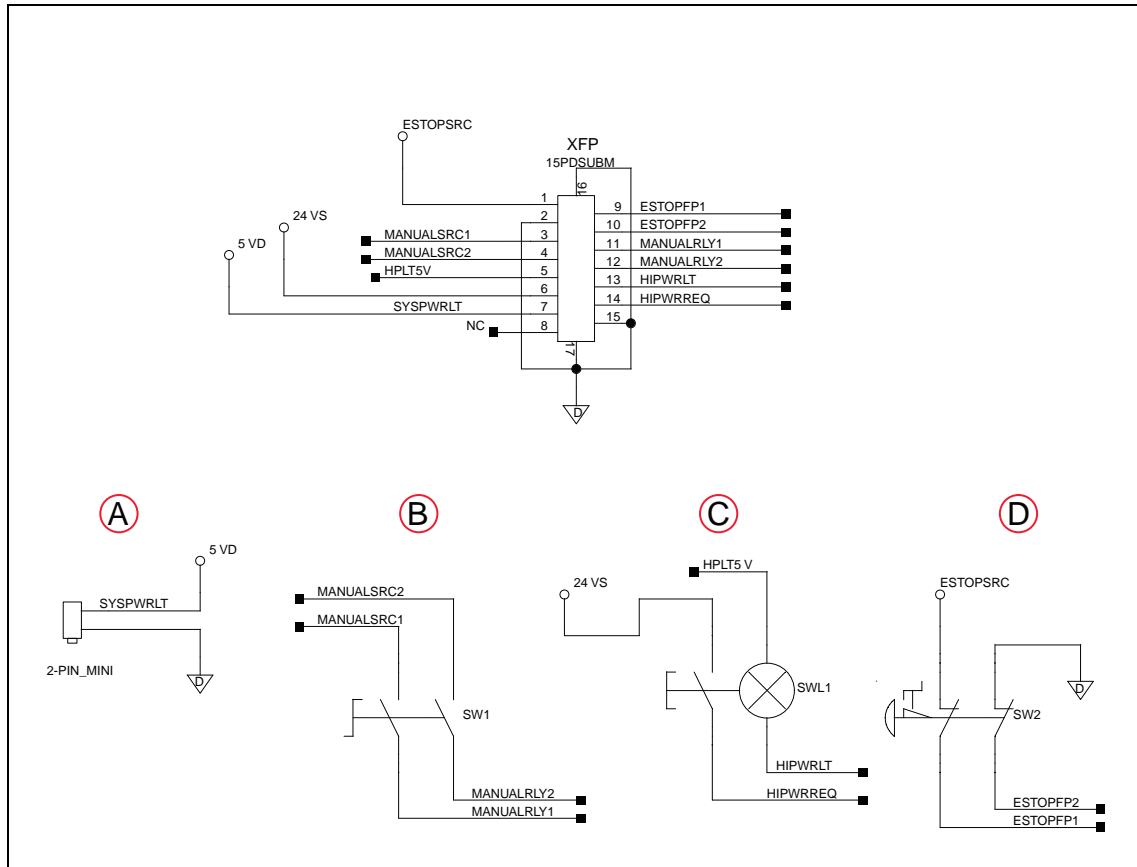

Figure 9-6. Front Panel Schematic

Key	Meaning	Key	Meaning
A	System Power LED	C	HIGH POWER ON/OFF
B	MANUAL/AUTO	D	EMERGENCY STOP

Emergency Stop Circuits

The eMB-40M XSYSTEM cable provides connections for Emergency Stop (E-Stop) circuits on the XUSR and XFP connectors. This gives the controller system the ability to duplicate E-Stop functionality from a remote location using voltage-free contacts. See Figure 9-5.

The XUSR connector provides external two-channel E-Stop input on pin pairs 1, 14 and 2, 15. The XFP connector provides two-channel E-Stop input on pin pairs 1, 9 and 2, 10.

NOTE: These pin pairs must be shorted if not used. Both channels must open independently if used. The controller will flag an error state if one channel is jumpered closed and the other channel is opened, although an Emergency Stop will still occur. It will also flag an error state if the independent channels are crossed, meaning one line from each channel is accidentally connected to the other channel.

User E-Stop Indication Contacts - Remote Sensing of E-Stop

These contacts provide a method to indicate the status of the ESTOP chain, inclusive of the Front Panel Emergency Stop push-button, the pendant Emergency Stop push-button, and the User Emergency Stop Contacts.

NOTE: These contacts do not indicate the status of any connections below the User E-Stop contacts. Thus, they will NOT indicate the status of the Line E-Stop, MCP ENABLE, or the Muted Safety gate. If you have a specific need in this area, contact your local Omron support for information on alternate indicating modes.

Two pairs of pins on the XUSR connector (pins 7, 20 and 8, 21) provide voltage-free contacts, one for each channel, to indicate whether the E-Stop chain, as described above, on that channel is closed. Both switches are closed on each of the redundant circuits in normal operation (no E-Stop). The user may use these contacts to generate an E-Stop for other equipment in the workcell. The load on the contacts must not exceed 40 VDC or 30 VAC at a maximum of 1 A.

These voltage-free contacts are provided by a redundant, cyclically-checked, positive-drive, safety relay circuit for Category 3 PL-d per ISO 13849 operation (see Table 9-1. and Table 9-2. for the customer E-Stop circuitry).

Line E-Stop Input

The XUSR connector on the controller contains a two-channel Line E-Stop input for workcell, production line, or other equipment emergency-stop inputs. Generally, the customer E-Stop Indication contact outputs are used to generate an emergency stop in such external equipment. Thus, if one were to wire the same equipment's outputs into the customer E-Stop input (that is, in series with the local robot's E-Stop push-buttons), a lock-up situation could occur.

The Line E-Stop input comes into the circuit at a point where it cannot affect the customer E-Stop indication relays and will not cause such a lock-up situation. For any situation where two systems should be cross-coupled, for example, the customer E-Stop indication of one controller is to be connected to the input of another controller, the Line E-Stop input is the point to bring in the other controller's output contacts. See the figure E-Stop Circuit on XUSR and XFP Connectors on page 92 for more information.

Do not use the Line E-Stop for such devices as local E-Stop push-buttons, since their status should be reported to the outside on the local user E-Stop indication output contact while the Line E-Stop inputs will not.

Muted Safety Gate E-Stop Circuitry

Two pairs of pins on the XUSR connector (pins 5, 18 and 6, 19) provide connections for a safety gate designed to yield an E-Stop allowing access to the workspace of the robot in Manual mode only, not in Automatic mode. It is up to the customer to determine if teaching the robot in Manual Mode, by a skilled programmer (See Qualification of Personnel in the *Robot Safety Guide*), wearing safety equipment and carrying a pendant, is allowable under local regulations. The E-Stop is said to be "muted" in Manual mode (for the customer E-Stop circuitry, see the figures and tables at the beginning of this section).

The muted capability is useful for a situation where a shutdown must occur if the cell gate is opened in Automatic mode, but you need to open the gate in Manual mode. If the mute gate is opened in Automatic mode, the robot defaults to Manual mode operation when power is re-enabled. In muted mode, the gate can be left open for personnel to work in the robot cell. However, safety is maintained because of the speed restriction.



WARNING: PERSONAL INJURY

Whenever possible, manual mode operations should be performed with all personnel outside the workspace.



CAUTION: PERSONAL INJURY

If you want the cell gate to always cause a robot shutdown, wire the gate switch contacts in series with the user E-Stop inputs. Do not wire the gate switch into the Muted Safety Gate inputs.

Remote Manual Mode

The Front Panel provides for a Manual Mode circuit. See Remote High Power On/Off Control on page 97 for further details about the customer Remote Manual Mode circuitry.

The Front Panel, or the user-supplied panel, must be incorporated into the robot workcell to provide a “Single Point of Control” (the pendant) when the controller is placed in Manual mode. Certain workcell devices, such as PLCs or conveyors, may need to be turned off when the operating mode switch is set to Manual mode. This is to ensure that the robot controller does not receive commands from devices other than the pendant, the single point of control.

If the user needs to control the Manual/Automatic mode selection from other control equipment, then a custom splitter cable or complete replacement of the Front Panel may be required. See Front Panel Schematic on page 94. In this situation, a pair of contacts should be wired *in series* with the Front Panel Manual/Automatic mode contacts. Thus, both the Front Panel and the customer contacts need to be closed to allow Automatic mode.



WARNING: PERSONAL INJURY

Do not wire user-supplied Manual/Automatic contacts in parallel with the Front Panel switch contact. This would violate the “Single Point of Control” principle and might allow Automatic (high-speed) mode to be selected while an operator is in the cell.

User Manual/Auto Indication

Two pairs of pins on the XUSR connector (pins 9, 22 and 10, 23) provide a voltage-free contact to indicate whether the Front Panel and/or remote Manual/Automatic switches are closed. The user may use these contacts to control other mechanisms (for example, conveyor, linear modules, etc.) when Manual mode is selected. The load on the contacts should not exceed 40 VDC or 30 VAC at a maximum of 1 A.



WARNING: PERSONAL INJURY

Any safeguards that were suspended must be returned to full functionality prior to selecting Automatic Mode.

User High Power On Indication

In the optional SmartController EX, eV+ controls a normally-open relay contact on the XDIO connector (pins 45, 46. See the table *XDIO Digital I/O Connector Pin Assignments* in the

SmartController EX User's Guide), that will close when high power has been enabled. The user can use this feature to power an indicator lamp or other device, that signals High Power is On. The limit on these contacts is 1 A at 30 VDC or 30 VAC.

Remote High Power On/Off Control

The easiest and most effective way to provide the high power on/off control in a remote location is to mount the Front Panel in the desired location with an extension cable.

However, if the user needs to control high power on/off from other control equipment or from a location other than the Front Panel, then a custom splitter cable will be required. See the Front Panel schematic (Front Panel Schematic on page 94) for details of the Front Panel's wiring. In this situation, a second momentary contact for high power on/off would be placed *in parallel with* the Front Panel push-button contact. This second contact should be suppressed when in Manual mode (see the note on "Single Point of Control" below).

This method allows relocating the push-button switch to a more convenient location. Implementation of this method must conform to EN standard recommendations.

NOTE: European standards require that the remote High Power push-button be located outside of the workspace of the robot.

Pins 6, 14 and 5, 13 of the XFP connector provide this remote capability. Pins 5, 13 provide power for the lamp, +5 VDC and ground, respectively. Pins 6, 14 are inputs for voltage-free normally-open contacts from a user-supplied momentary push-button switch.



WARNING: PERSONAL INJURY

To fulfill the "Single Point of Control" requirement, do not place the Manual/Automatic and High Power On controls in multiple locations.

After putting the robot into Manual mode, the operator should remove the key for safety purposes. The system should not be wired so that a PLC or another operator can put the system back into Automatic mode.

High Power On/Off Lamp

The Front Panel High Power On/Off Lamp (P/N: 27400-29006) will cause an error, from eV+, if the lamp burns out. This error prevents High Power from being turned on. This safety feature prevents a user from thinking that High Power is disabled if the High Power indicator is burned out. See Changing the Lamp in the Front Panel Option High-Power Indicator on page 127 for information on changing this lamp for a factory-supplied Front Panel.

Remote Front Panel or User-Supplied Control Panel Usage

Users can mount the Front Panel remotely by using an extension cable or by wiring a user-supplied Front Panel (control panel) to the controller using the 15-pin XFP connector. The Front Panel contains no active components, only switches and lights. Customers should be able to adapt the Front Panel's functionality into their own Front Panel design. To automatically control the Front Panel's signals, use relay contacts instead of switches. See the figure Front Panel Schematic on page 94 for a schematic drawing of the Front Panel, and see Table 9-2. for a summary of connections and pin numbers.

NOTE: The system was evaluated by Underwriters Laboratory with an Omron Adept Technologies, Inc.-supplied Front Panel. Using other equipment in place of this Front Panel could void UL compliance.

Users can build an extension cable to place the Front Panel in a remote location. The extension cable must conform to the following specifications:

- Wire Size: must be larger than 26 AWG.
- Connectors: must be 15-pin, standard D-sub male and female.
- Maximum cable length is 10 m.

NOTE: The XMCP and XFP connectors can be interchanged without electrical damage. However, neither the Front Panel nor the pendant will work properly unless they are plugged into the correct connector.

Remote Pendant Usage

Customers can build an extension cable to place the pendant in a remote location. The extension cable must conform to the following specifications:

- Wire Size must be larger than 26 AWG.
- Connectors must be 15-pin, standard D-sub male and female.
- Maximum cable length is 10 m.



CAUTION: PERSONAL INJURY/PROPERTY DAMAGE

Do not modify the cable that is attached to the pendant. This could cause unpredictable behavior from the robot system.

Chapter 10: System Operation

10.1 Status Panel Codes

The status panel display on the eMB-40M displays alpha-numeric codes that indicate the operating status of the robot, including detailed fault codes. eMotionBlox-40M on page 27 gives definitions of the fault codes. These codes provide details for quickly isolating problems during troubleshooting. For more details, see eMotionBlox-40M on page 27.

10.2 Front Panel Option

NOTE: The optional Omron Adept Front Panel E-Stop is designed in accordance with the requirements of IEC 60204-1 and ISO 13849.



WARNING: PERSONAL INJURY/PROPERTY DAMAGE

Any user-supplied front panel E-Stop must be designed in accordance with the requirements of IEC 60204-1 and ISO 13849. The push button of the E-Stop must comply with ISO 13850 (Clause 5.5.2).

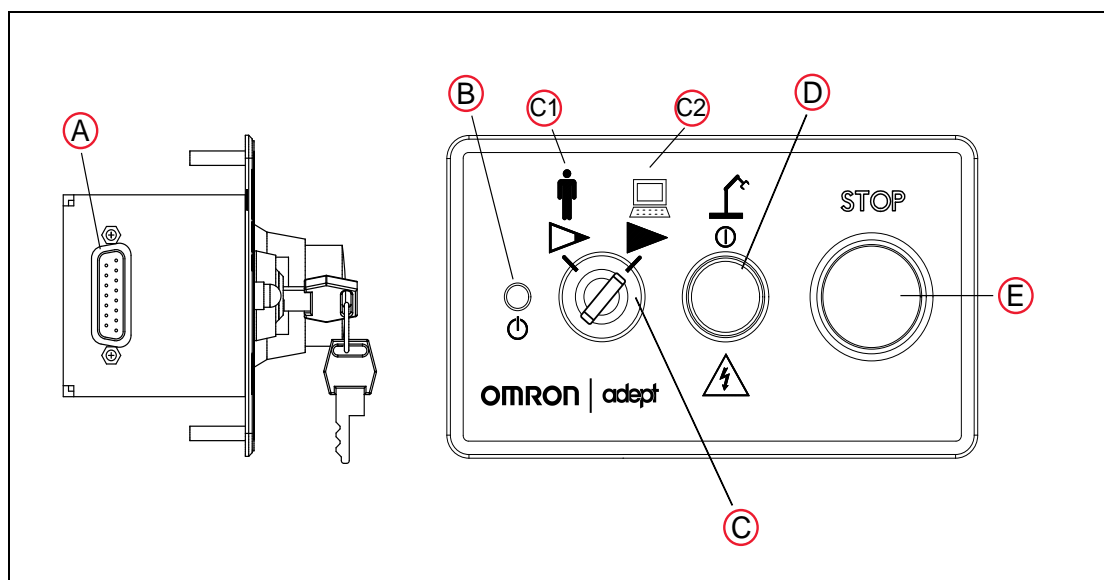

Figure 10-1. Front Panel

- A. **XFP connector**
Connects to the XFP connector on the eAIB XSYSTEM cable (or on the optional SmartController EX).
- B. **System 5 V Power-On LED**
Indicates whether or not power is connected to the robot.

C. Manual/Automatic Mode Switch

Switches between Manual (C1) and Automatic (C2) modes. In Automatic mode, executing programs control the robot, and the robot can run at full speed. In Manual mode, the system limits robot speed and torque so that an operator can safely work in the cell. Manual mode initiates software restrictions on robot speed, commanding no more than 250 mm/s.

There is no high speed mode in manual mode.



WARNING: PERSONAL INJURY

Make sure any personnel who use the robot in manual mode are skilled and instructed - refer to the *Robot Safety Guide*.



WARNING: PERSONAL INJURY

If an operator is going to be in the work cell in manual mode, it is strongly recommended that the operator carry an enabling device. The Enable button on the manual control pendant is such a device.

D. High Power On/Off Switch and Lamp

Controls high power, which is the flow of current to the robot motors. Enabling high power is a two-step process. An “Enable Power” request must be sent from the user-supplied PC, an executing program, or the optional pendant. Once this request has been made and the High Power On/Off lamp/button is blinking, the operator must press and release this button, and high power will be enabled.

NOTE: The use of the blinking High Power button can be configured (or eliminated) in software. Your system may not require this step.



WARNING: PERSONAL INJURY

Disabling the High Power button violates IEC 60204-1. It is strongly recommended that you not alter the use of the High Power button.

NOTE: If enabled, the Front Panel button must be pressed while blinking (default time-out is 10 seconds). If the button stops blinking, you must enable power again.

E. Emergency Stop Switch

The E-Stop is a dual-channel, passive E-Stop that supports Category 3 CE safety requirements. Pressing this button turns off high power to the robot motors.

An E-Stop does not immediately stop the robot. The system intentionally takes slightly less than one second to bring the robot to a controlled stop.

NOTE: You must install the Front Panel to enable power to the robot. To operate without the optional Front Panel, you must supply the equivalent circuits.

10.3 Initial Power-up of the System

The first time you power-up the system, you must follow the steps in this section to safely bring up your robot system. The tasks include:

- Verifying installation, to confirm all tasks have been performed correctly
- Starting up the system by turning on power for the first time
- Verifying all E-Stops in the system function correctly
- Moving each joint of the robot (with the pendant or ACE software Jog Control) to confirm that each moves in the proper directions

Verifying Installation

Verifying that the system is correctly installed and that all safety equipment is working correctly is an important process. Before using the robot, make the following checks to ensure that the robot, eMB-40M, and optional SmartController have been properly installed.



WARNING: PERSONAL INJURY OR PROPERTY DAMAGE RISK
After installing the robot, you must test it before you use it for the first time. Failure to do this could cause serious injury, equipment damage, or possible death.

Mechanical Checks

- Verify that the robot is mounted level and that all fasteners are properly tightened
- Verify that any end-of-arm tooling is properly installed
- Verify that all other peripheral equipment is properly installed, such that it is safe to turn on power to the robot system

System Cable Checks

Verify the following connections:

NOTE: The first three connections are made via the eAIB XSYSTEM cable if you are not using an optional SmartController EX motion controller.

- Front Panel to the XSYSTEM on the eMB-40M.
This can be the optional Omron Adept Technologies, Inc. Front Panel or a user-supplied front panel with the equivalent circuits.
- Pendant to the XSYSTEM on the eMB-40M, if pendant is used..
This must be jumpered if not used.
- XUSR to the XSYSTEM on the eMB-40M.
This must be jumpered if not used.

- User-supplied 200/240 VAC power to the robot 200/240 VAC connector.
- User-supplied 24 VDC power to the eMB-40M 24 VDC connector.

If you are using an optional SmartController EX, you should check the following:

- eAIB XSYS cable between the eMB-40M interface panel XSYSTEM connector and XSYS connector on the SmartController, and the latching screws tightened.

- Front Panel to the SmartController.

This can be the optional Omron Adept Technologies, Inc. Front Panel or a user-supplied front panel with the equivalent circuits.

- Pendant to the SmartController EX, via the pendant adapter cable.
- User-supplied 24 VDC power to the controller.
- User-supplied ground wire between the SmartController and ground.
- One end of the IEEE 1394 cable into the SmartServo connector on the SmartController, and the other end into a SmartServo connector on the eMB-40M interface panel.

User-Supplied Safety Equipment Checks

Verify that all user-supplied safety equipment and E-Stop circuits are installed correctly.

System Start-up Procedure

After the system installation has been verified, you are ready to start up the system.

1. Switch on AC power to the eMB-40M.



WARNING: PERSONAL INJURY

Make sure personnel are skilled and instructed - refer to the *Robot Safety Guide*.

2. Switch on the 24 VDC power to the eMB-40M.
3. Switch on the 24 VDC power to the SmartController EX, if present.

The eMB-40M Status Panel displays OK (**OK**). The Status LED will be off.

4. Verify that the optional Front Panel or user-supplied front panel is set to Auto Mode.
5. Follow the instructions, beginning with Starting the ACE Software, in the following section.

Running the ACE Software

Starting the ACE Software

The robot should be on, and the eMB-40M status panel should display OK (**OK**) before proceeding.

1. Turn on the user-supplied PC and start ACE.
 - Double-click the ACE icon on your Windows desktop,
or
 - From the Windows Start menu bar, select:
Start > Programs > Omron > ACE x.y
where x is the ACE major version, and y is the ACE minor version. For example,
for ACE 3.8, it would be:
Start > Programs > Omron > ACE 3.8
2. On the ACE Getting Started screen:
 - Select Connect To Controller.
 - Identify the IP address of the controller you wish to connect to either by manually typing into the text box or selecting from the list of available controllers.

NOTE: The IP addresses of the PC network adapter and robot controller must be configured correctly. If necessary, the robot controller IP address can be changed in “Controller IP Address Detection and Configuration”. To access this menu click on the search icon:



3. Click OK. You will see the message “Working, please wait”.

Enabling High Power

After you have started ACE and connected to the controller, enable high power to the robot motors.

Using ACE to Enable High Power

1. From the ACE main menu, click the Enable High Power icon .
2. Press and release the blinking High Power button on the Front Panel within 10 seconds.

The Front Panel is shown in Figure 10-1. (If the button stops blinking, you must Enable Power again.)

NOTE: The use of the blinking High Power button and safety timeout can be configured (or eliminated) in software. Your system may not require this step.



WARNING: PERSONAL INJURY
Disabling the High Power button violates IEC 60204-1. It is strongly recommended that you not alter the use of the High Power button.

This step turns on high power to the robot motors.

- The eMB-40M Status LED glows amber.
- The code on the eMB-40M Status Panel displays ON. See eMotionBlox-40M on page 27.

Verifying E-Stop Functions

Verify that all E-Stop devices are functional (pendant, Front Panel, and user-supplied). Test each mushroom button, safety gate, light curtain, etc., by enabling high power and then opening the safety device. The High Power push button/light on the front panel should go out for each.

Verify Robot Motions

Use the pendant (if purchased) to verify that the robot moves correctly. Refer to the *T20 Pendant User's Guide* for complete instructions on using the pendant.

If the optional pendant is not installed in the system, you can move the robot using the Robot Jog Control in the ACE software. For details, see the *ACE User's Guide*.

10.4 Learning to Program the Cobra 450, 500, and 650 Robots

To learn how to use and program the robot, see the *ACE User's Guide*, which provides information on robot configuration, control and programming through the ACE software “point and click” user interface.

For eV+ programming information, refer to the eV+ User and Reference guides.

Chapter 11: Optional Equipment

11.1 Installing End-Effectors

The user is responsible for providing and installing any end-effector or other end-of-arm tooling. End-effectors can be attached to the tool flange using four screws. See Tool Flange Dimensions (Units in mm) on page 135 for a detailed dimension drawing of the tool flange.

If hazardous voltages are present at the end-effector, you must install a ground connection from the base of the robot to the end-effector.

Refer to User Connections on Robot on page 85 for information on providing air and electric connections to your end-effectors.

11.2 Add-on Equipment

SmartController EX

The SmartController EX motion controller can coordinate up to four robots. It increases the I/O available, provides for tracking up to four additional conveyors, and raises the number of serial ports by 3.

The SmartController EX supports the DeviceNet option, and allows for the use of third-party vision systems. One RS-485 port is available.

The SmartController EX is covered in the SmartController EX User's Guide.

SmartVision MX

The SmartVision MX is an industrial PC that can provide vision-oriented connectivity via ACE software. Refer to the SmartVision MX User's Guide for more details.

T20 Pendant

The T20 pendant provides manual control of a Cobra robot. This is generally used when teaching pick and place locations. Refer to the T20 Pendant User's Guide.

NOTE: Omron Adept Technologies, Inc. does not offer a cableless (wireless) pendant.

Front Panel

NOTE: The E-Stop on the Omron Adept Technologies, Inc. Front Panel is designed in accordance with the requirements of IEC 60204-1 and ISO 13849.



WARNING: PERSONAL INJURY/PROPERTY DAMAGE

Any user-supplied front panel E-Stop must be designed in accordance with the requirements of IEC 60204-1 and ISO 13849. The push-button of the E-Stop must comply with ISO 13850 (Clause 5.5.2).

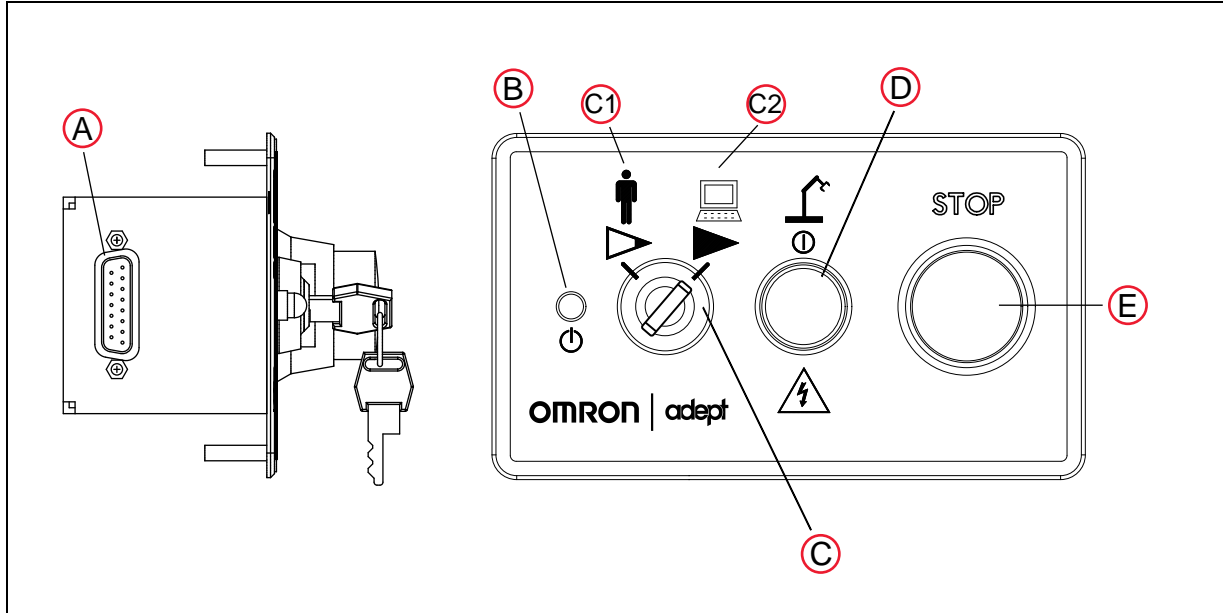

Figure 11-1. Front Panel (Option)

- A. XFP connector: Connects to the XFP connector on the eAIB XSYSTEM cable (or the optional SmartController EX, if one is being used).
- B. System 5 V Power-On LED: Indicates whether or not power is connected to the robot.
- C. Manual/Automatic Mode Switch: Switches between Manual (C1) and Automatic (C2) modes. In Automatic mode, executing programs control the robot, and the robot can run at full speed. In Manual mode, the system limits robot speed and torque so that an operator can safely work in the cell. Manual mode initiates hardware and software restrictions on robot speed, commanding no more than 250 mm/s.

There is no high speed mode in manual mode.



WARNING: PERSONAL INJURY

If an operator is going to be in the work cell in manual mode, it is strongly recommended that the operator carry an enabling device. The Enable button on the T20 pendant is such a device.

Whenever possible, manual mode operations should be performed with all personnel outside the workspace.

- D. High Power On/Off Switch and Lamp: Controls high power, which is the flow of current to the robot motors. Enabling high power is a two-step process. An “Enable Power” request must be sent from the user-supplied PC, an executing program, or a pendant. Once this request has been made and the High Power On/Off lamp/button is blinking, the operator must press and release this button, and high power will be enabled.

NOTE: The use of the blinking High Power button can be configured (or eliminated) in software. Your system may not require this step.

**WARNING: PERSONAL INJURY**

Disabling the High Power button violates IEC 60204-1. It is strongly recommended that you not alter the use of the High Power button.

NOTE: If enabled, the Front Panel button must be pressed while blinking (default time-out is 10 seconds). If the button stops blinking, you must enable power again.

- E. Emergency Stop Switch: The E-Stop is a dual-channel, passive E-Stop that supports Category 3 CE safety requirements. Pressing this button turns off high power to the robot motors.

NOTE: The Front Panel must be installed to be able to Enable Power to the robot. To operate without a Front Panel, the user must supply the equivalent circuits.

Power Cable Kit - P/N 04972-000

This includes cables for VAC and VDC.

XIO Breakout Cable

The XIO Breakout cable connects to the XIO connector on the eMB-40M, and provides flying leads on the user's end, for connecting input and output signals in the workcell. The cable length is 5 m (16.4 ft). See XIO Input Specifications on page 41.

NOTE: This cable is not compatible with the XIO Termination Block.

Y Cable

Used for XSYS cable connections to multiple robots. This is available as an option with the SmartController EX.

eAIB XBELT IO Adapter Cable

The optional eAIB XBELT IO Adapter cable splits the eAIB XBELTIO port into a belt encoder lead, an Intelligent Force Sensing or IO Blox lead, and an RS-232 lead. If the system has a SmartController EX, this is only needed for Intelligent Force Sensing.

Belt Encoder to M12 Y-Adapter Cable

Splits the Belt Branch of the eAIB/eMB - Force/Expio, Belt, RS-232 cable into two encoder cables.

Brake Release Box

You can install a brake-release box, to release the brake on Joint 3.

If you choose to build your own brake release mechanism, refer to Brake Release Connector on page 36.

The brake-release box shown here is available as an option (05522-000).



WARNING: INJURY OR PROPERTY DAMAGE

When the Brake Release is activated, Joint 3 may drop to the bottom of its travel. To prevent possible damage to the equipment, make sure that Joint 3 is supported while releasing the brake and verify that the end-effector or other installed tooling is clear of all obstructions.

Installing and Using the Brake Release Box

This procedure describes how to install and use a brake release box (05522-000). See the following figure.

1. Make sure that high power is disabled (off).
2. Remove any payload from the end-effector.
3. Connect the 9-pin male D-sub connector into the 9-pin female D-sub connector marked BRAKE on the eMB-40M.
4. Press one of the E-Stops (Pendant, Front Panel, or external).

NOTE: An E-Stop must be activated in order for the brake release box to work.

5. Turn the selector switch to 1.

Since the robot only has one brake, position 1 was used to release it.

6. Depress the Brake Release push button to release the brake.

The brake will stay released for as long as you hold in the push button.

NOTE: When the Status LED (Green) is on, it indicates that the circuit is enabled, when the Brake Release push button is pressed.

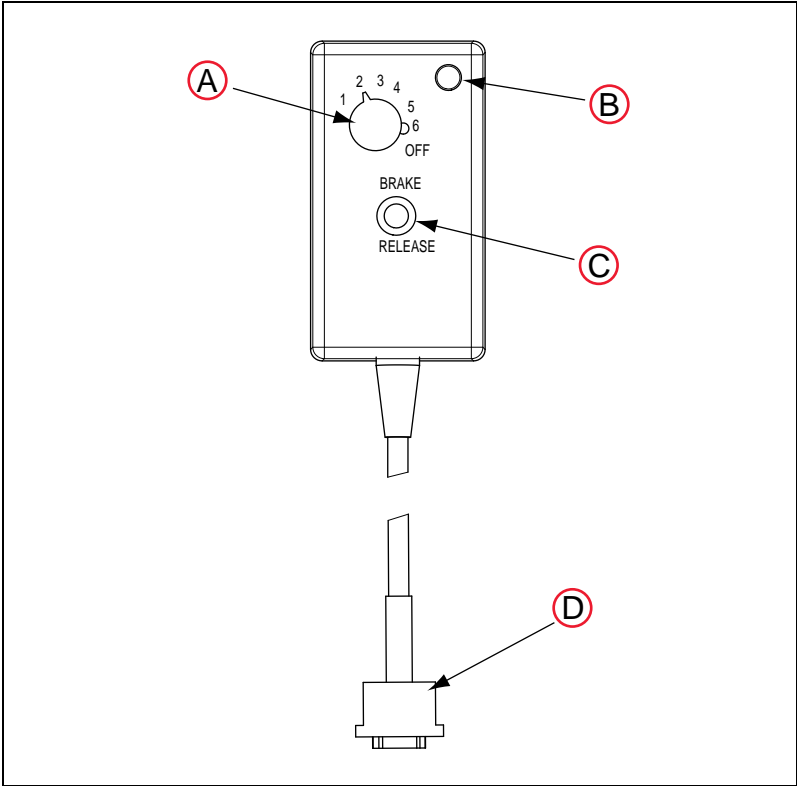

Figure 11-2. Brake Release Box

Key	Meaning	Key	Meaning
A	Selector Switch	C	Brake-release Push Button
B	Status LED	D	9 Pin Male D-sub Connector

Chapter 12: Maintenance

12.1 Periodic Maintenance Schedule

The following table gives a summary of the preventive maintenance procedures and guidelines on frequency.

Table 12-1. Inspection and Maintenance

Item	Period	Reference
Safety Labels	1 week	
Check E-Stop, enable and key switches, and barrier interlocks	3 months	Checking Safety Systems on page 115.
Check robot mounting bolts	After first week	Checking Robot Mounting Bolts on page 116
	6 months	
Lubricate Joint 3 ball screw	3 months	Lubricate Ball Screw (Joint 3) on page 116
Replace Encoder battery	2 - 4 years	Replacing Encoder Battery Pack on page 118
Inspect timing belts on 3rd and 4th joints	3 months	Inspecting Timing Belts on page 121



WARNING: PERSONAL INJURY

The procedures and replacement of parts mentioned in this section should be performed only by skilled or instructed persons, as defined in the *Robot Safety Guide*.

The access covers on the robot are not interlocked – turn off and lockout/tagout power if any covers have to be removed.



WARNING: PERSONAL INJURY/PROPERTY DAMAGE

During maintenance, user-supplied fail-safe lock-out measures must be used to prevent unauthorized third parties from turning on power.

This is mandated by Clause 5.2.4 of ISO 10218-1.

Warning Labels

All warning labels on the Cobra 450, 500, and 650 should be checked on a weekly basis for being present and legible. If any of the labels are missing or illegible, they should be replaced.

The labels, with part numbers, are:

- Read User's Guide, Impact Warning Label - P/N 18301-000

These labels instruct the user to read the user's guide before using the robot, and to be aware of the potential of impact by the robot.

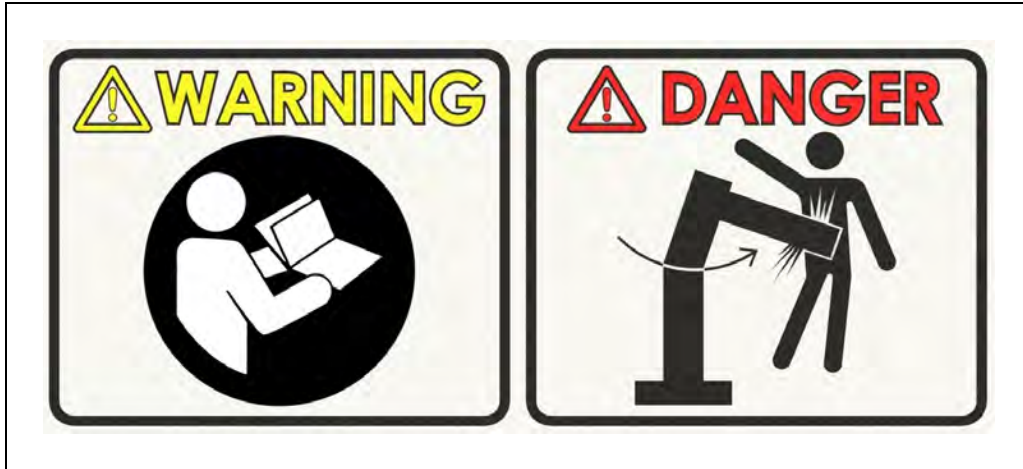

Figure 12-1. Read Manual and Impact Warning Label

This is placed on the side of the robot base, above the label with the model and serial number information.

The following labels are all on the face of the eMB-40M.

NOTE: The labels are not to scale.

- Brake-release/Gravity Warning - P/N 18272-000



Figure 12-2. Brake-release/Gravity Warning Label

This label warns about the possibility of a robot joint dropping suddenly because of gravity when the brake release is activated. In the case of the Cobra 450, 500, and 650, this applies to the J3 shaft, tool flange, and any end-effectors attached to it.

- Shock/Disconnect Power Warning - P/N 03467-000
This is the label on the left in the following figure.
- High Temperature and High Voltage - P/N 03466-000
This is the label on the right in the following figure.



Figure 12-3. Shock and High Voltage/High Temperature Labels

- Lockout and Tagout Warning - P/N 08607-000



Figure 12-4. Lockout Tagout Warning Label

- Warning: Disconnect 24V Before Removing Encoder Cable - P/N 19302-000



Figure 12-5. Encoder Disconnect Warning

- Generic Ground Label - P/N 05307-000



Figure 12-6. Ground Label

Checking Safety Systems

NOTE: The T20 pendant and Front Panel are both options. If the Front Panel is not purchased, the user must replace its functionality with equivalent circuits.

Perform these tests every six months.

1. Test operation of:
 - E-Stop button on the front panel
 - E-Stop button on pendant
 - Enabling switch on pendant
 - Auto/Manual switch on front panel

NOTE: Operating **any** of the above buttons or switches should disable High Power.

2. Test operation of any external (user supplied) E-Stop buttons.
3. Test operation of barrier interlocks, etc.

Checking Robot Mounting Bolts

Check the tightness of the base-mounting bolts after one week, and then every 6 months. Tighten to 110 N·m.

Lubricate Ball Screw (Joint 3)

Required Grease for the Ball Screw

Table 12-2. Robot Lubrication

Lubrication Point	Lubrication Type	Lubrication Amount	Remarks
Joint 3 shaft	AFA (THK)	2 to 3 cc	Apply grease to entire shaft.



CAUTION: PROPERTY DAMAGE
 Using improper lubrication products on the Cobra 450, 500, or 650 robots may cause damage to the robots.

Lubrication Procedure

Figure 12-7. Lubrication of Joint 3 Shaft, Upper Position

1. Lower the ball screw shaft to its lowest position.
2. Turn OFF main power to the eMB-40M controller.
3. Apply grease to the exposed portion of the ball screw shaft.
4. Turn ON main power to the eMB-40M controller and raise the ball screw shaft to its highest position.
5. Turn OFF main power to the eMB-40M controller.
6. Remove the 2-piece Joint 2 cover.

Remove the screws on the sides first and then those on the top.

7. Apply grease to the exposed portion of the ball screw shaft.
8. Wipe off any excess grease.
9. Re-install the 2-piece cover for Joint 2.
10. Turn ON main power to the eMB-40M controller and move the ball screw shaft up and down several times to spread the grease.
11. Perform a test operation to verify proper operation.

Replacing Encoder Battery Pack

The data stored by the encoders is protected by a battery pack attached to the inner side of the robot Interface Panel with hook-and-loop tape. This battery pack also powers the Robot Signature Card (RSC), which is attached to the same harness that the battery pack is attached to.

Battery Replacement Intervals

If the robot is kept in storage and not in production, or the robot is turned off (no 24 VDC supply) most of the time, then the battery should be replaced every 2 years.

If the robot is turned on with 24 VDC supplied to the robot more than half the time, then you can increase the replacement interval to a maximum of 4 years.

Replacement Procedure

1. Obtain a replacement battery pack, P/N 09977-100.
2. Switch off the SmartController EX, if present.
3. Switch off the 24 VDC input supply to the eMB-40M.
4. Switch off the 200/240 VAC input supply to the eMB-40M.
5. Disconnect the 24 VDC supply cable from the eMB-40M +24 VDC input connector. See Figure 4-2. for locations of connectors.
6. Disconnect the Motor Power cable from the eMB-40M connector.

Lock out and tag out power.

7. Remove the Interface Panel from the robot by removing six hex M5 socket-head screws, as shown in the following figure.

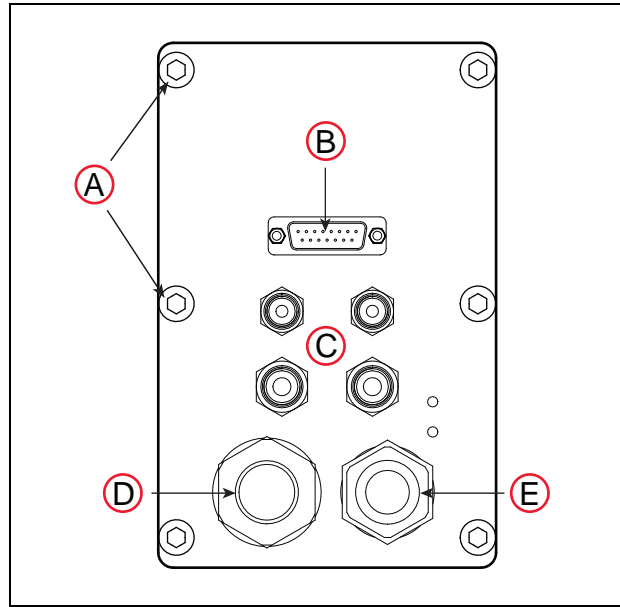

Figure 12-8. Removing Battery Cover (Cables not Shown)

Key	Meaning	Key	Meaning
A	Hex M5 Screws (2 of 6)	D	Encoder Cable
B	15-pin User I/O Connector	E	Motor Cable
C	Air Connectors		

- Attach the new backup battery pack to the spare (unused) connector on the battery harness. See the following figure for details.

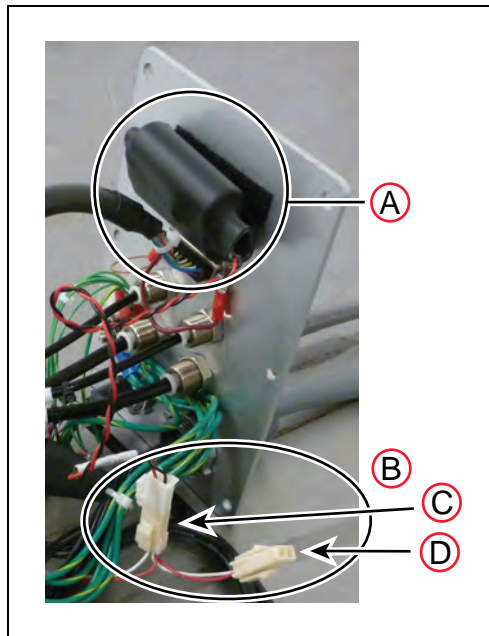

Figure 12-9. Replacement Battery Pack

Key	Meaning
A	Battery Pack Mounted to Inner Side of Robot Interface Panel
B	Battery Connectors
C	In-use on left
D	Spare on right

IMPORTANT: Always leave at least one battery pack connected at all times. Failure to do so will lose the encoder positional data, requiring recalibration.

NOTE: The battery pack is attached to the inner side of the robot interface panel, near the top, with hook-and-loop fastener strips.

- Disconnect the old battery pack from the battery harness and remove it from the robot Interface Panel.

NOTE: Dispose of the battery pack according to all local and national environmental regulations regarding electronic components.

- Attach the new battery pack to the hook-and-loop strip on the inner side of the robot interface panel.
- Reinstall the robot Interface Panel on the robot.

Ensure that no wires get pinched between the panel and the robot base.

12. Reconnect the Motor Power cable to the eMB-40M.
13. Restore 24 VDC and 200/240 VAC input power to the eMB-40M.

Inspecting Timing Belts

This inspection should be done every 3 months.

1. Switch off the SmartController EX, if present.
2. Switch off the 24 VDC input supply to the eMB-40M.
3. Switch off the 200/240 VAC input supply to the eMB-40M.
4. Disconnect the 24 VDC supply cable from the eMB-40M +24 VDC input connector. See Figure 4-2. for locations of connectors.
5. Disconnect the Motor Power cable from the eMB-40M connector.
Lock out and tag out power.
6. Remove the 2-piece Joint 2 cover.
Remove the screws on the sides first and then those on the top.
7. Visually inspect the timing belts for Joint 3 and Joint 4 for excessive wear or missing teeth.
8. If you discover any problems, contact your local Omron support.
9. Re-install the 2-piece cover for Joint 2.
10. Reconnect the Motor Power cable to the eMB-40M.
11. Restore 24 VDC and 200/240 VAC input power to the eMB-40M.

12.2 Non-Periodic Maintenance

Replacing the eMB-40M Amplifier

Remove the eMB-40M Amplifier

1. Switch off the SmartController EX, if present.
2. Switch off the 24 VDC input supply to the eMB-40M.
3. Switch off the 200/240 VAC input supply to the eMB-40M.
Lock out and tag out power.
4. Disconnect the 24 VDC supply cable from the eMB-40M +24 VDC input connector.
See Connectors on eMB-40M Interface Panel on page 28 for locations of connectors.
5. Disconnect the 200/240 VAC supply cable from the eMB-40M connector.
6. Disconnect the eAIB XSYSTEM cable or eAIB XSYS cable (SmartController EX) from the eMB-40M XSYSTEM connector.
7. Disconnect the Ethernet cable or the IEEE 1394 cable (SmartController EX) from the

eMB-40M.

8. Disconnect the Motor Power cable from the Motor Power connector on the eMB-40M.
9. Disconnect the Robot Encoder cable from the Robot Encoder connector on the eMB-40M.
10. Disconnect any other cables that are connected to the eMB-40M.

Installing a New eMB-40M

1. Carefully remove the new eMB-40M from its packaging, check it for any signs of damage, and remove any foreign packing materials or debris.
2. Connect the 200/240 VAC supply cable to the eMB-40M AC input connector.
3. Connect the eAIB XSYSTEM cable, or the eAIB XSYS cable (SmartController EX) to the eMB-40M XSYSTEM connector.
4. Connect the Ethernet cable or the IEEE 1394 cable (SmartController EX) to the appropriate connector.
5. Connect the Motor Power cable from the robot to the Motor Power connector on the eMB-40M.
6. Connect the Robot Encoder cable from the robot to the Robot Encoder connector on the eMB-40M.
7. Connect any other cables that were connected to the eMB-40M.
8. Connect the 24 VDC supply cable to the eMB-40M +24 VDC input connector.
9. Switch on the 200/240 VAC input supply to the eMB-40M.
10. Switch on the 24 VDC input supply to the eMB-40M.
11. Switch on the SmartController EX, if present.
12. Once the system has completed booting, test it for proper operation.

Commissioning a System with an eMB-40M

Commissioning a system involves synchronizing the robot with the eMB-40M.

For a new system with an eMB-40M, the robot and the eMB-40M will have been commissioned at the factory and should not need commissioning.

In rare cases with a new robot with an eMB-40M, you may need to commission the system.

- If the system will not power up, and the status display shows SE, you need to commission the system.
- If the system will not power up in Manual mode, and the status display shows TR, you need to commission the system.

Safety Commissioning Utilities

The eMB-40M adds two functions that implement safety in hardware:

- E-Stop
This serves as a backup to the standard software E-Stop process. The system will always try to stop the robot using the software E-Stop first. The hardware E-Stop will take over in the event of a failure of the software E-Stop.
- Teach Restrict feature
This limits the maximum speed of the robot when it is operated in Manual mode. As with the E-Stop, this is a hardware backup to software limits on robot speed. If the software fails to limit the robot speed during manual operation, the hardware Teach Restrict feature will disable power to the system.

These two functions are supported by four wizards:

- E-Stop Configuration
This sets the E-Stop hardware delay to factory specifications.
- E-Stop Verification
This verifies that the hardware E-Stop is functioning correctly.
- Teach Restrict feature Configuration
This sets the hardware Teach Restrict feature maximum speed to factory specifications.
- Teach Restrict feature Verification
This verifies that the hardware Teach Restrict feature is functioning correctly.

The initial utility screen will tell you which functions are commissioned. If a function is not commissioned, its verification wizard will not be displayed. Any displayed verification wizard can be run at any time, to ensure that its function is working properly.

Prerequisites

- The robot must be set up and functional.
- ACE software must be installed.
- The Front Panel (option) keyswitch or user-supplied equivalent must be in Auto mode.

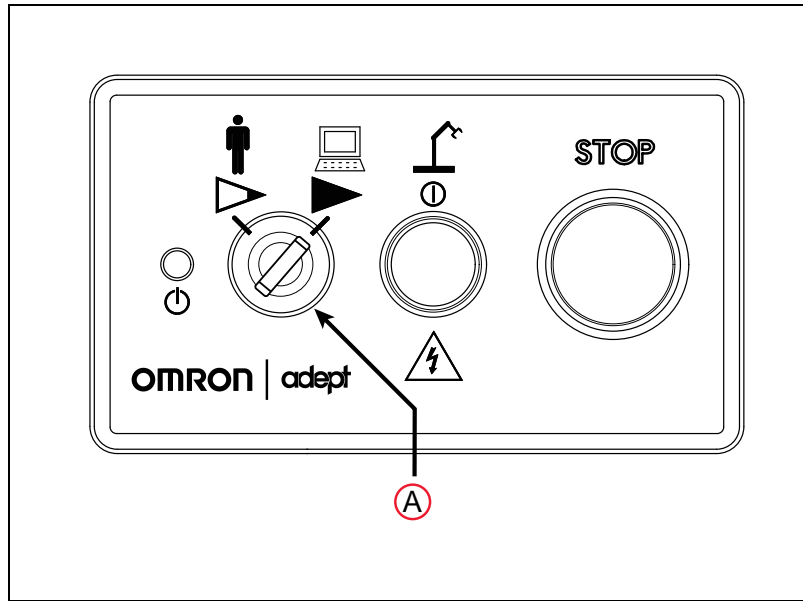

Figure 12-10. Front Panel Option. (A) Keyswitch in Auto Mode

- No E-Stops can be activated.
- For Configuration (E-Stop and Teach Restrict), the eAIB Commissioning Jumper must be plugged into the XBELTIO jack on the eMB-40M.

NOTE: This is the only time that this jumper will be used. It is P/N 11901-000, and must be removed for Verification and normal operation.



Figure 12-11. eAIB Commissioning Jumper

- A pendant is required for the Teach Restrict feature verification.

E-Stop Configuration Utility

This utility sets the E-Stop hardware delay to factory specifications.

NOTE: Ensure that the commissioning jumper is plugged into the XBELTIO jack on the eMB-40M before you start this procedure.

Procedure

NOTE: In this procedure, the word “controller” means the SmartController EX, if there is one in your system, or, if not, the eMB-40M.

From within the ACE software:

1. Open the robot object editor.
2. Select **Configure > Safety Settings > Configure ESTOP Hardware Delay**, then click Next.

This procedure will configure Channel A and then Channel B. It will then report the delay that it set.

3. Reboot the controller.

On some systems, the controller will reboot automatically.

4. Reboot the eMB-40M.

E-Stop Verification Utility

This utility verifies that the hardware E-Stop parameters are set correctly and that the hardware E-Stop is working.

The hardware E-Stop must have already been configured for this wizard to run.

NOTE: If the commissioning jumper is plugged into the XBELTIO jack on the eMB-40M, remove it before you start this procedure.

Procedure

From within the ACE software:

1. Open the robot object editor.
2. Select **Configure > Safety Settings > Verify ESTOP Hardware Delay**, then click Next.
3. Enable high power, if not already enabled, then click Next.
4. Press an E-Stop button (on the Front Panel option or equivalent), then click Next.

The utility will confirm that the hardware delay has been verified for this robot, and display the delay time.

5. Reboot the controller.

On some systems, the controller will reboot automatically.

Teach Restrict feature Configuration Utility

This utility sets the hardware Teach Restrict feature maximum speed parameter to factory specifications.

NOTE: Ensure that the commissioning jumper is plugged into the XBELTIO jack on the eMB-40M before you start this procedure.

Procedure

NOTE: This procedure takes 2 or 3 minutes to complete.

From within the ACE software:

1. Open the robot object editor.
2. Select **Configure > Safety Settings > Configure Teach Restrict**, then click Next.
3. From the Prerequisite screen, click Next.

The wizard will go through all of the robot's motors, and display messages that it is configuring Channel A and B for each.

It will then record the configuration, and display the target times that it set.

4. Click Finish.
5. Reboot the controller.

On some systems, the controller will reboot automatically.

Teach Restrict feature Verification Utility

This utility verifies that the Teach Restrict feature parameters are set correctly and that the hardware Teach Restrict feature maximum speed control is working.

This is a two-part wizard. The first is run in Auto mode. The second is run in Manual mode.

Before running this verification utility, the Teach Restrict feature must be configured.

NOTE: If the commissioning jumper is plugged into the XBELTIO jack on the eMB-40M, remove it before you start this procedure.

Automatic Mode Procedure



WARNING: IMPACT RISK.

The robot will move during this wizard. Ensure that personnel stay clear of the robot work area.

From within the ACE software:

1. Open the robot object editor.
2. Select **Configure > Safety Settings > Verify Teach Restrict**, then click Next.
3. Teach a Start Position.

This can be any position that does not conflict with obstacles or the limits of joint movements.

- If the robot is already in such a position, you can just click Next.
- Otherwise, move the robot to such a position, then click Next.

- The screen will display the number of degrees that each joint is expected to move during the verification process.
- You can click Preview Motions on this screen to view the motions at slow speed. The default speed is 10, but you can change that speed with this screen's speed control.
- You can click Move to Ready, to move the robot to the Ready position.

The robot will move each joint, in succession. It will generate an over-speed condition for each, and verify that the hardware detected the over-speed condition.

4. Click Next, to proceed to the Manual Mode Procedure.

If the Automatic Mode Procedure fails, you will not be allowed to proceed with the Manual Mode.

Manual Mode Procedure

The manual mode of this verification requires the use of a pendant.

For this verification, the Front Panel (option or equivalent) keyswitch must be in Manual mode.

1. From the Introduction screen, click Next.
 - Set the pendant to Joint mode.
 - Set the pendant manual control speed to 100.
2. Click Next.
3. Using the pendant, jog any of the robot's joints until power is disabled.

This indicates that the Teach Restrict feature function is working.
4. Click Next.

The results of the verification will be displayed.
5. Click Finish.
6. Reboot the controller.

On some systems, the controller will reboot automatically.
7. Reset the keyswitch to Auto mode.

Changing the Lamp in the Front Panel Option High-Power Indicator

NOTE: The following procedure to replace the High Power indicator lamp only applies to the optional Omron Adept Technologies, Inc. Front Panel. The part number for the lamp is 27400-29006.

The system is equipped with circuitry to detect the potentially dangerous condition of a burned-out High Power indicator on the Front Panel. If this lamp is burned out, you cannot enable high power until the lamp has been replaced.



WARNING: ELECTROCUTION RISK.
Lock out and tag out power before servicing.



WARNING: ELECTROCUTION RISK.
The procedures covered in this section should be performed only by trained, authorized personnel. The access covers on the robot, Front Panel, and eMB-40M are not interlocked – turn off and disconnect power before removing the covers.

1. Turn off system power to the robot.
2. Turn off power to the optional SmartController EX, if you are using one.
3. Disconnect the cable between the Front Panel and the eMB-40M (or controller).
4. Remove the Front Panel from its mounting location.
5. Remove the two screws on the back of the Front Panel.
Save the screws for re-installation.
6. Carefully pull the front cover away from the body of the Front Panel.

You will encounter some resistance, as there are three plug-type connectors that you need to disconnect as you pull the front cover away from the body.

NOTE: Separate the cover from the body slowly to avoid damaging the two wires that go between the LED and the PC board inside the body. Pull the front cover as straight out as possible. You do not have to disconnect the wires from the PC board, although you can if needed.

7. Locate the lamp body in the center of the back side of the front cover. Turn the lamp body approximately 20° in either direction and then pull straight back.
8. The lamp body is now free. You can remove the old lamp and insert a new one.
9. Re-install the lamp body by pushing it straight into the lamp housing receptacle. Make sure the contacts on the lamp body are properly oriented, as shown in the following figure.
10. Make sure to reconnect the wires from the LED if you disconnected them earlier.
11. Push the front cover into the body, taking care to align all of the plug-type connectors.
Verify that the wires do not get crimped as you reinstall the cover.
12. Re-install the two screws on the back of the body.
13. Re-install the Front Panel in its mounting.
14. Reconnect the cable between the Front Panel and the eMB-40M (or controller).

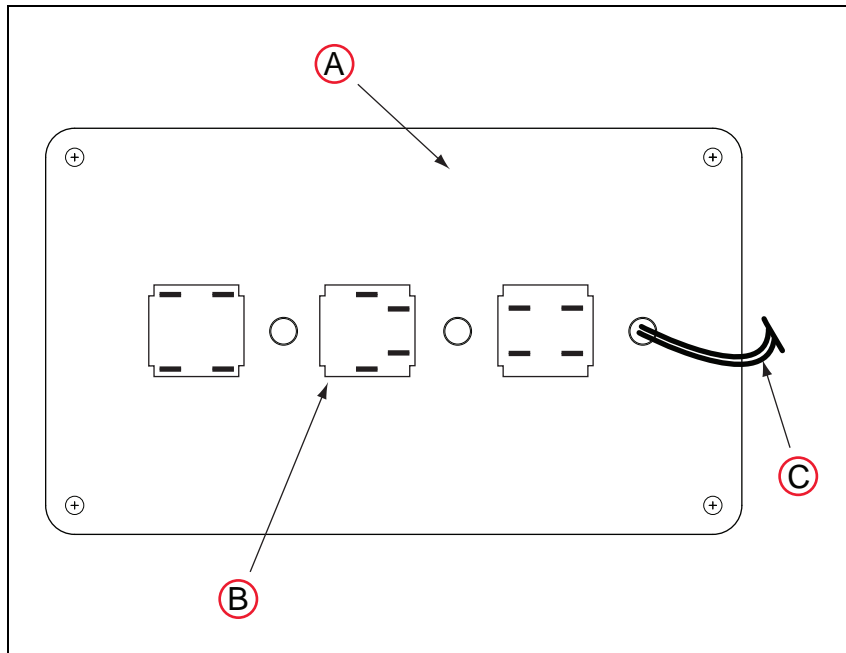

Figure 12-12. Lamp Body Contact Alignment

Key	Meaning
A	Back side of front cover
B	High Power On/Off Lamp Body
C	Wires between LED and body of Front Panel. Be careful when separating front cover from body to avoid damaging the wires.

Chapter 13: Technical Specifications

13.1 Dimension Drawings

Robot Dimensions

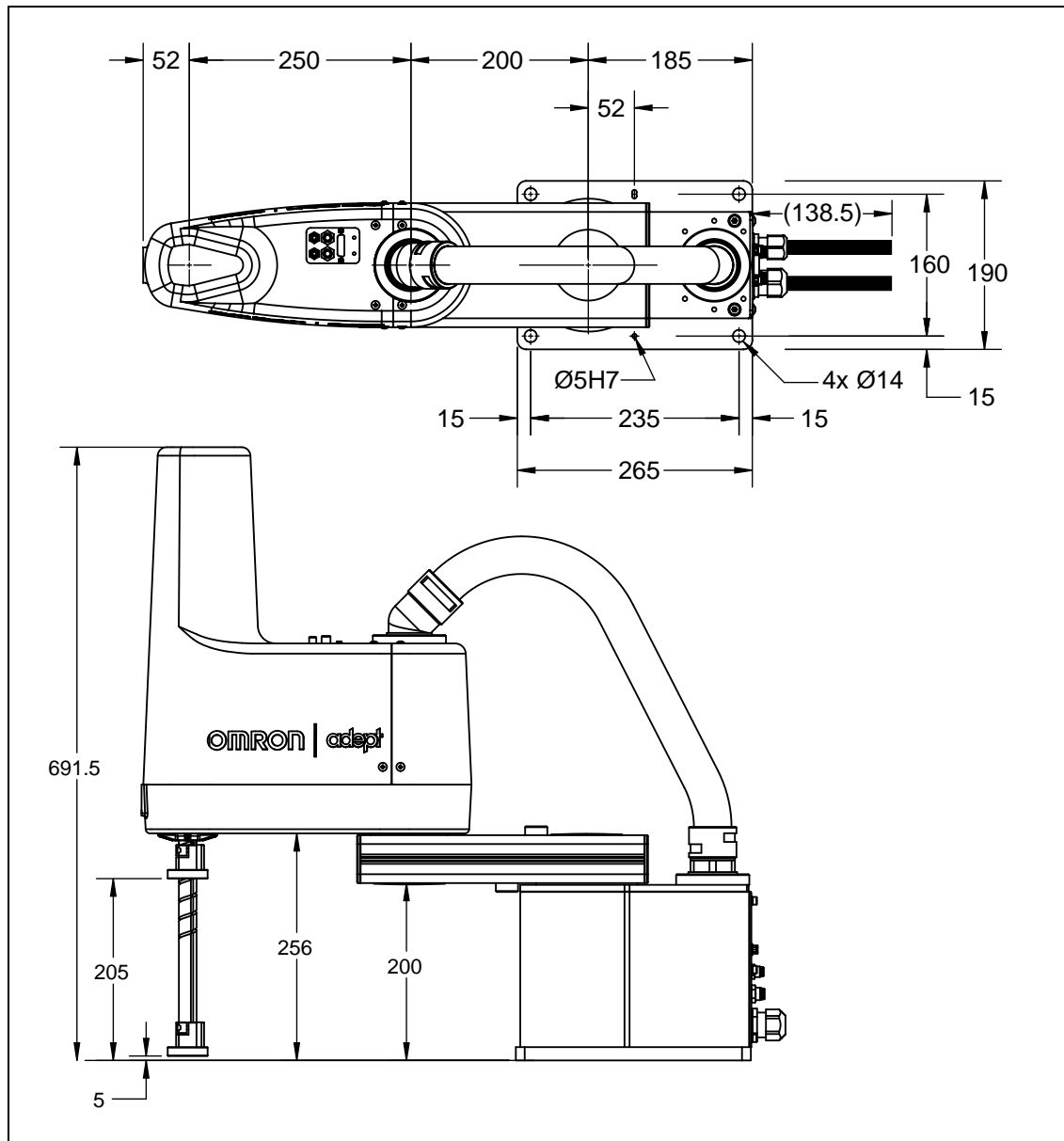

Figure 13-1. Cobra 450 Top and Side Dimensions, Cables not Shown (Units in mm)

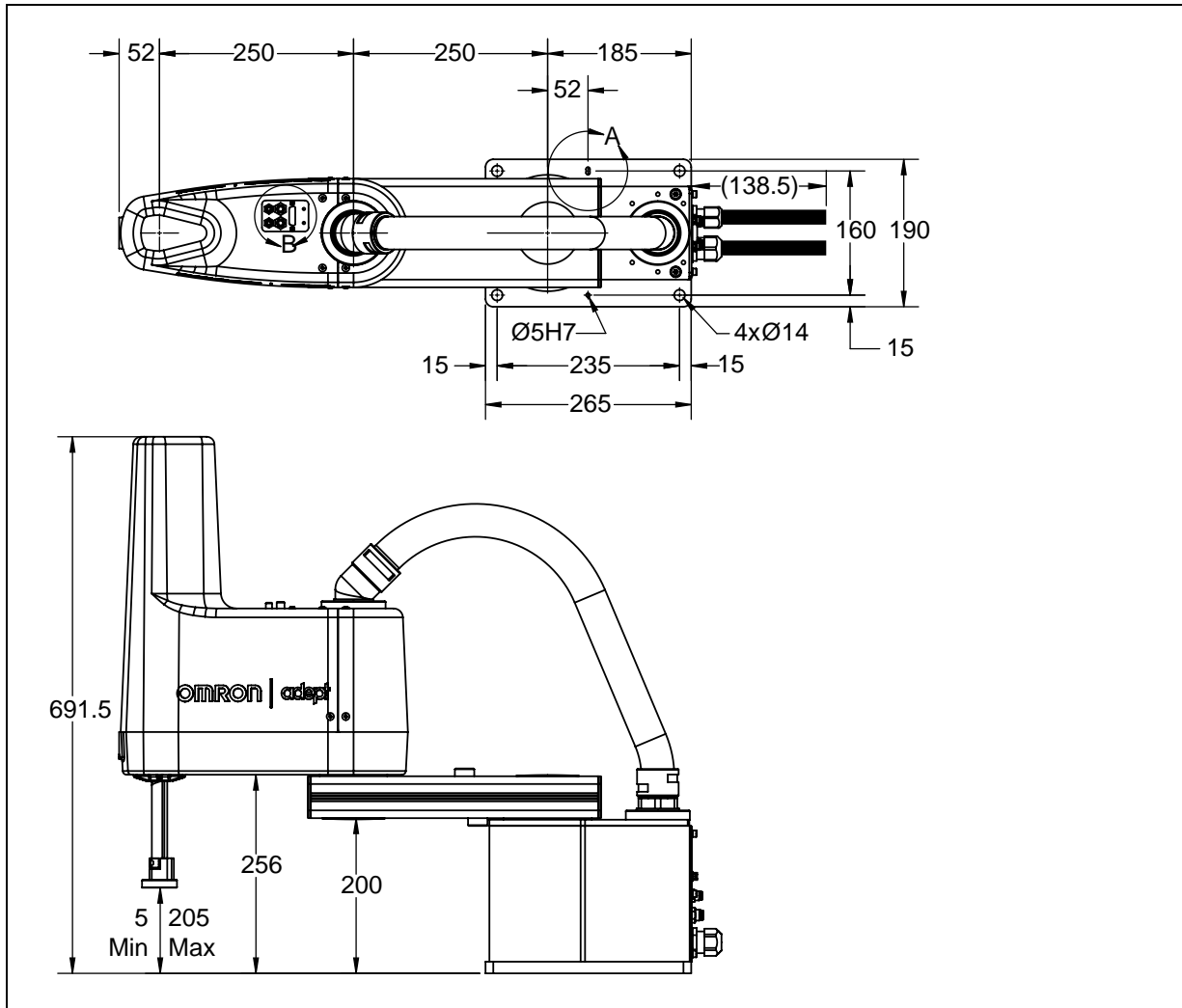

Figure 13-2. Cobra 500 Top and Side Dimensions, Cables not Shown (Units in mm)

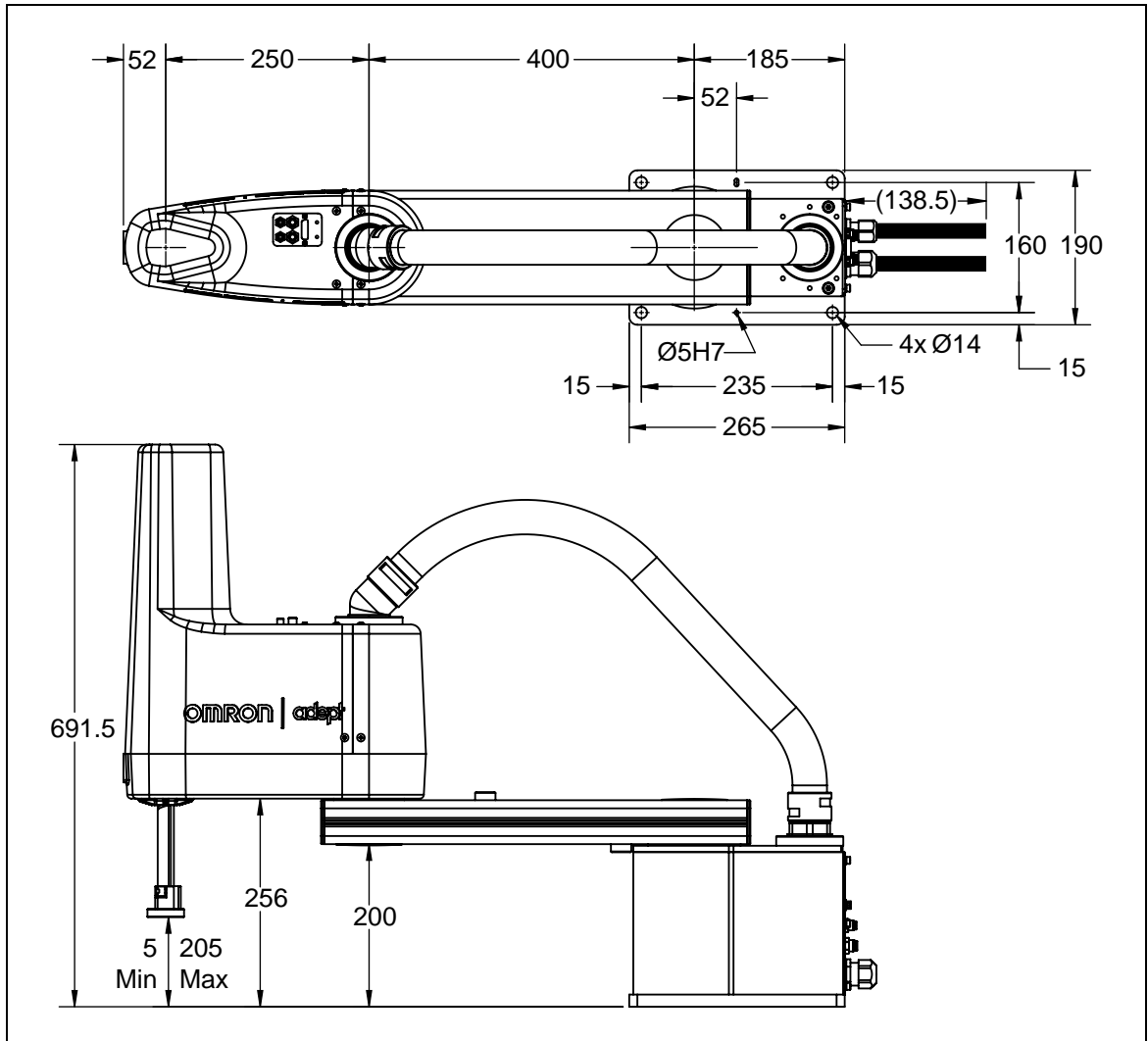

Figure 13-3. Cobra 650 Top and Side Dimensions, Cables not Shown, (Units in mm)

Mounting Dimensions

NOTE: Drawings, with dimensions, for mounting the eMB-40M are shown in Mounting the eMB-40M on page 48.

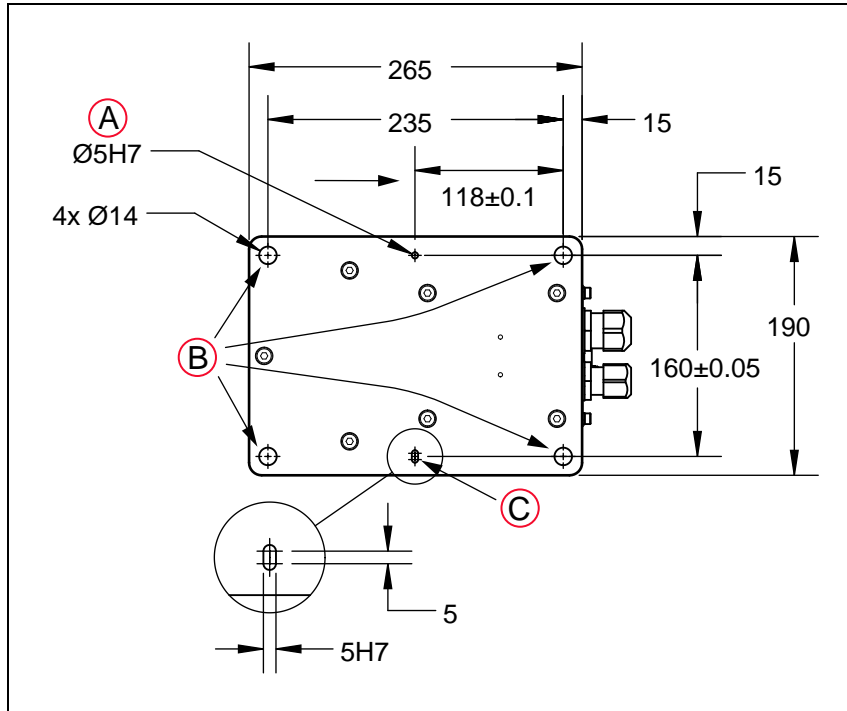

Figure 13-4. Mounting Hole Pattern for Robot, Bottom View (Units in mm)

Key	Meaning	Key	Meaning	Key	Meaning
A	Positioning Pin Hole	B	Base Mounting Holes	C	Positioning Pin Slot

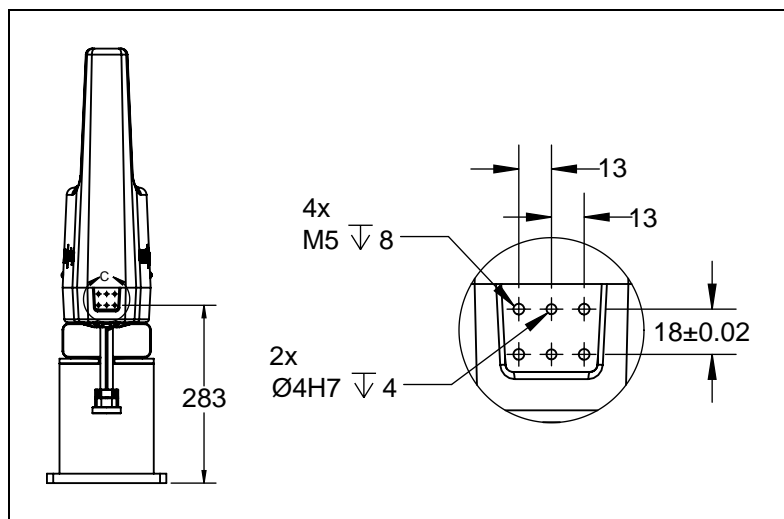

Figure 13-5. Joint 2 Front Camera/Option Mounting Hole Dimensions (Units in mm)

NOTE: The supplied tool flange sits 10.0 mm below the bottom of the Joint 3 shaft.

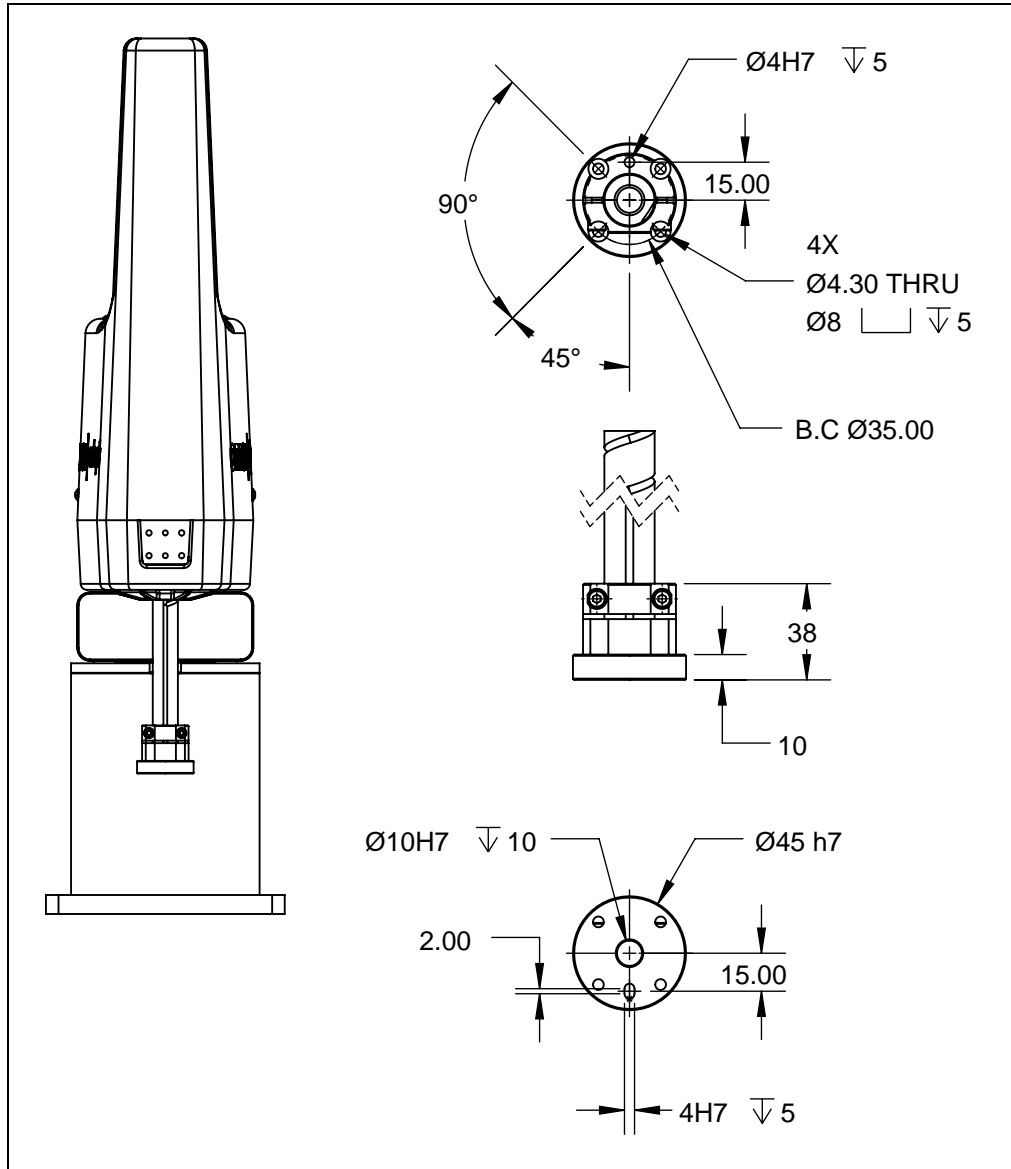

Figure 13-6. Tool Flange Dimensions (Units in mm)

NOTE: The range of movement of Joint 3 is shown in Figure 13-1.

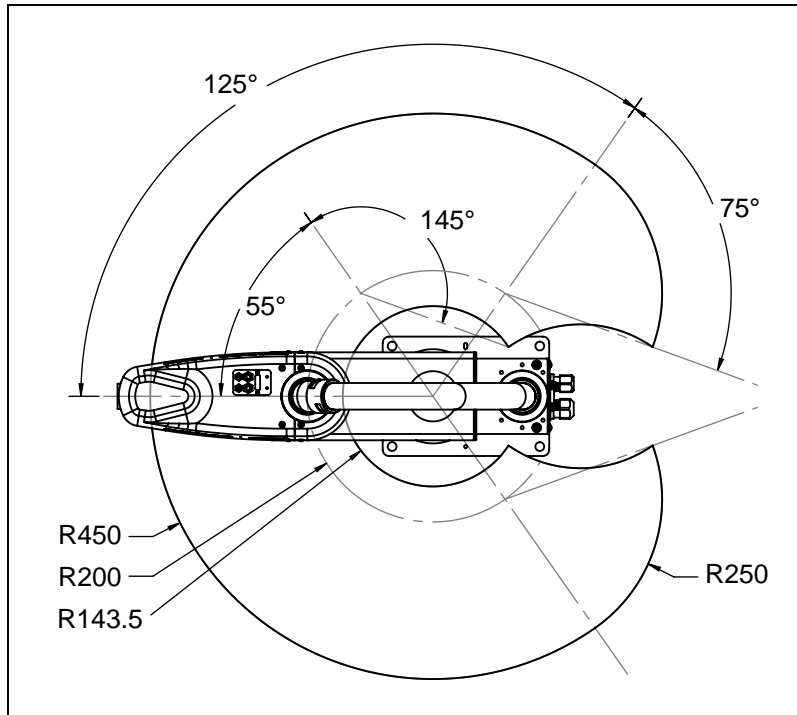

Figure 13-7. Cobra 450 Robot Working Envelope (Units in mm)

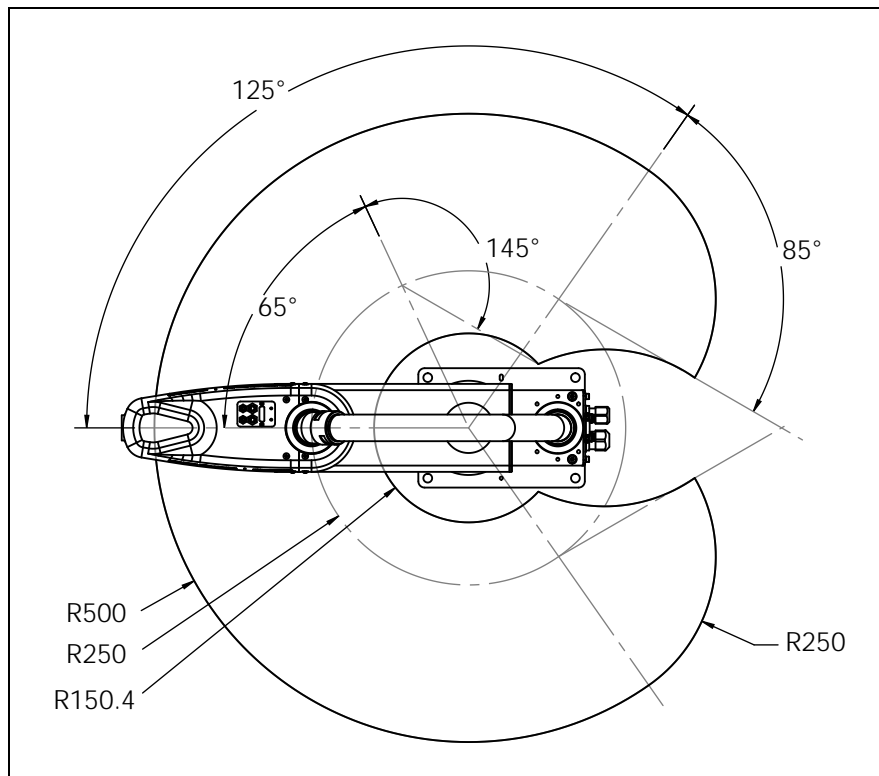

Figure 13-8. Cobra 500 Robot Working Envelope (Units in mm)

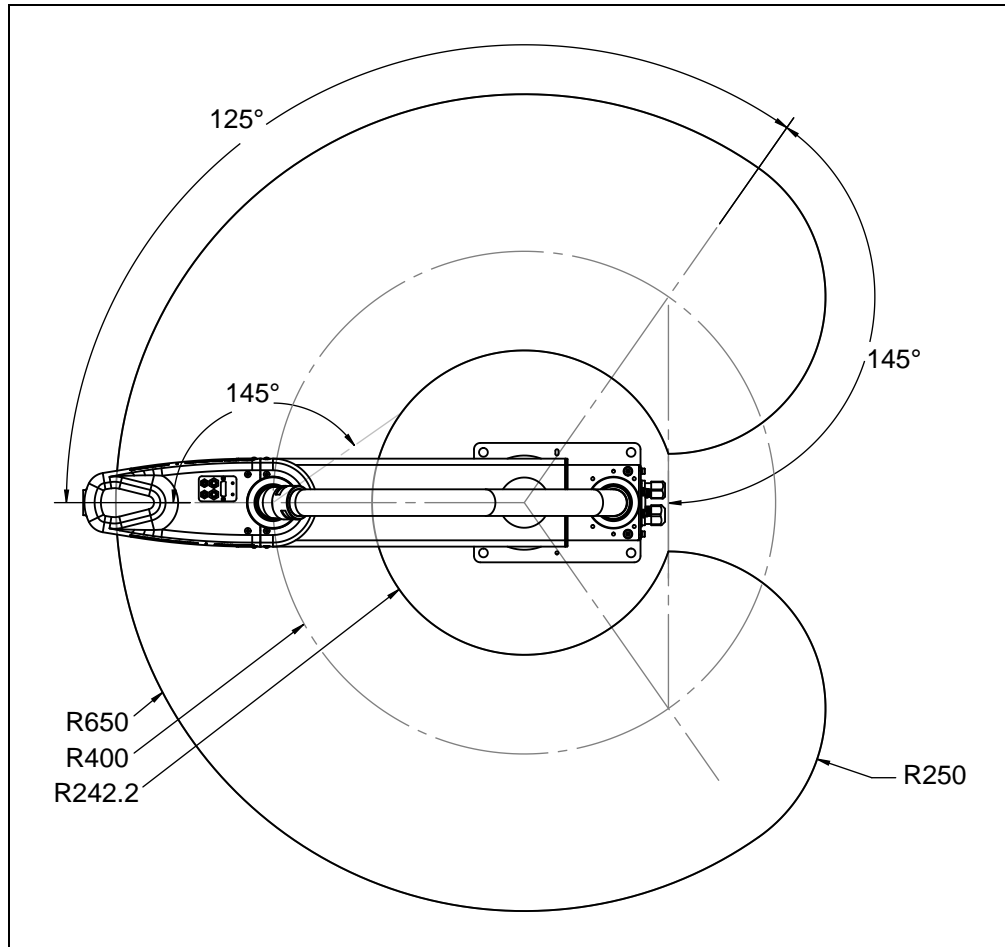

Figure 13-9. Cobra 650 Robot Working Envelope (Units in mm)

13.2 Robot Specifications

Physical

Table 13-1. Cobra 450, 500, and 650 Physical Robot Specifications¹

Description	Cobra 450	Cobra 500	Cobra 650
Reach	450 mm	500 mm	650 mm
Joint 1 Length	200 mm	250 mm	400 mm
Joint 2 Length	250 mm	250 mm	250 mm
Payload - rated/maximum	2.0 kg/5.0 kg		
Joint Range			
Joint 1	±125°		
Joint 2	±145°		
Joint 3	200 mm		
Joint 4	±360°		
Encoder type	Absolute		
Robot Brake	Joint 3: Electric		
Air line pass-through (quantity)	6 mm dia. (x2), 0.4 to 0.5 MPa 4 mm dia. (x2), 0.4 to 0.5 MPa		
Electrical pass-through	15 conductor D-sub AWG 25 (0.2 mm ²)		
Weight (without options)	29 kg	29 kg	31 kg
¹ Specifications subject to change without notice.			
² Rated is the weight used for time and speed measurements. Maximum is the heaviest weight the robot is designed to move.			

Performance

Table 13-2. Cobra 450, 500, and 650 Performance Specifications¹

Description	Cobra 450	Cobra 500	Cobra 650
Moment of Inertia	Joint 4 - 450 kg-cm ²		
Downward Push Force - Burst (no load)	100 N - maximum		
Repeatability, 2 kg			
X, Y	±0.02 mm	±0.02 mm	±0.02 mm
X	±0.01 mm	±0.01 mm	±0.01 mm
Theta	±0.005°	±0.005°	±0.005°
Joint Speed (maximum)			
Joint 1	450°/s	450°/s	450°/s
Joint 2	720°/s	720°/s	720°/s
Joint 3	1100 mm/s	1120 mm/s	1120 mm/s
Joint 4	1940°/s	1940°/s	1940°/s
Adept Cycle Burst/Sustained	0.49 s	0.51 s	0.43 s
	0.64 s	0.60 s	0.60 s
Noise Level	77.7 db	78.0 db	78.1 db
¹ Specifications subject to change without notice.			
² In mm 25/305/25 (seconds, at 20°C ambient)			

Table 13-3. Softstop and Hardstop Specifications

Joint	Softstop			Hardstop – Approx.		
	450	500	650	450	500	650
Joint 1	±125°	±125°	±125°	±128°	±128°	±128°
Joint 2	±145°	±145°	±145°	±147°	±147°	±147°
Joint 3, mm	0 to 200	0 to 200	0 to 200	-5 to 205	-5 to 205	-5 to 205
Joint 4	±360°	±360°	±360°	N/A	N/A	N/A

Stopping Distances and Times

The following graphs present information required by Clause 7.2 n) of ISO 10218-1. This information should be used to calculate the safe distance needed when designing and installing safeguarding devices.

The graphs show the time elapsed and distances traveled between the initiation of a stop signal and the cessation of all robot motion.

For stop category 1, the stopping time and distance values depend on the speed, load, and extension of the robot, stated for 0 kg, 2 kg, and 5 kg payloads. Data provided is for the three joints of greatest displacement (J1, J2 and J3).

NOTE: Where lines overlap (and may not be visible) differences are not significant.

Key to Graphs

Item	Meaning
Blue line	Payload 0 kg
Red line	Payload 2 kg
Green line	Payload 5 kg
A	Stopping Time in s
B	Stopping Distance in mm
C	Speed as %

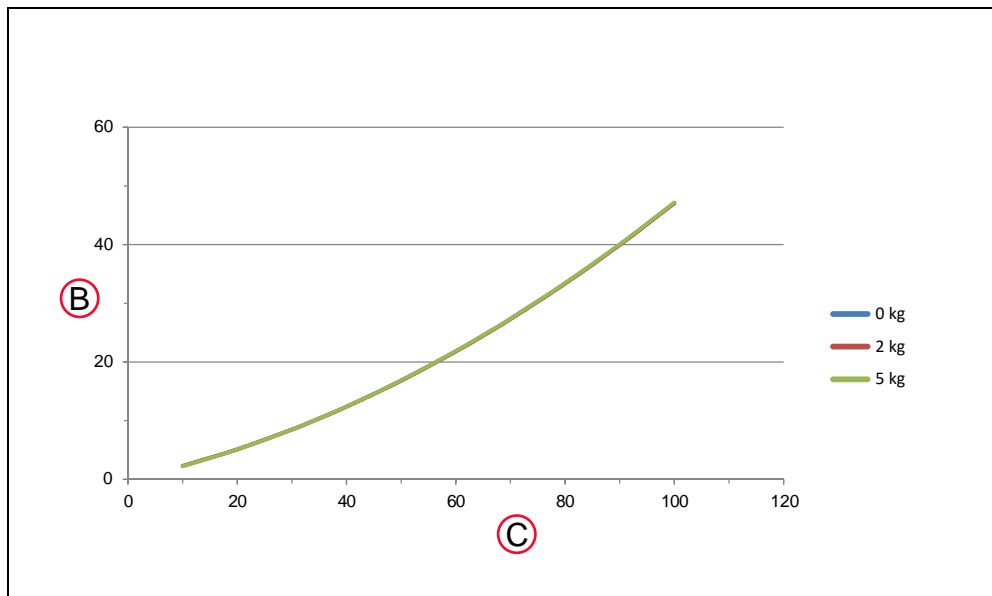

Figure 13-10. Joint 1 Stopping Distance for Cobra 450, in Degrees

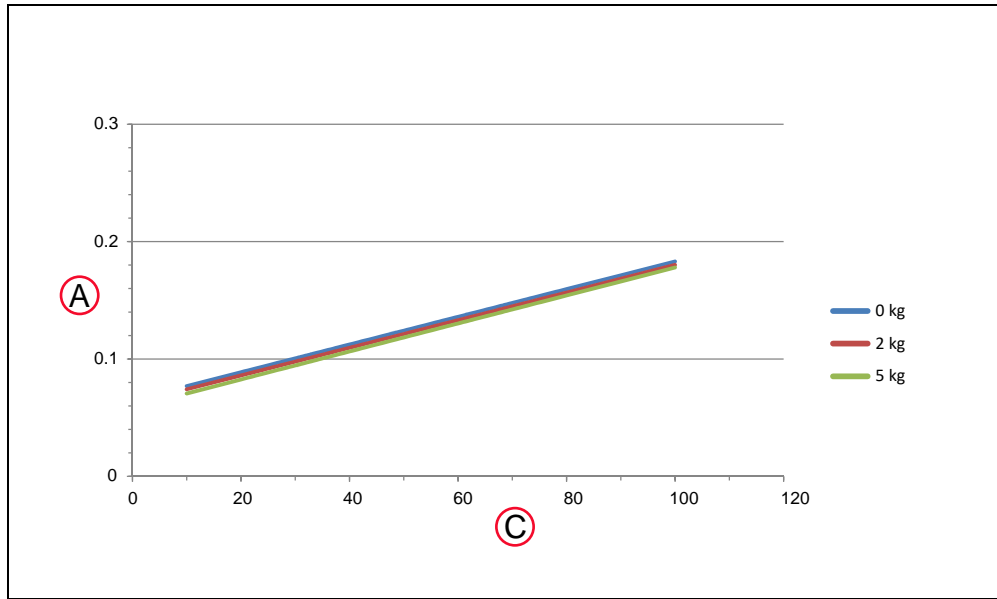

Figure 13-11. Joint 1 Stopping Time for Cobra 450, in Seconds

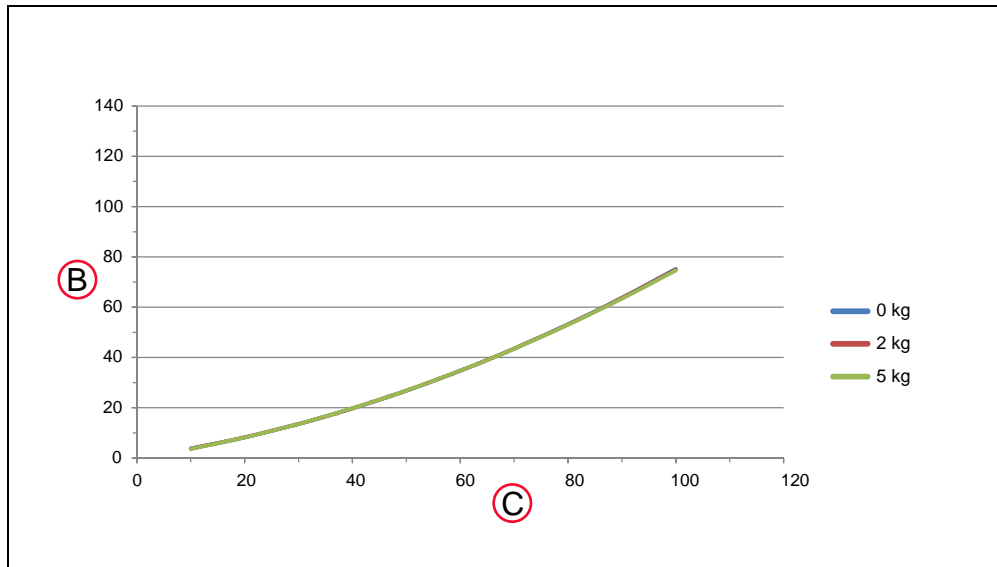

Figure 13-12. Joint 2 Stopping Distance for Cobra 450, in Degrees

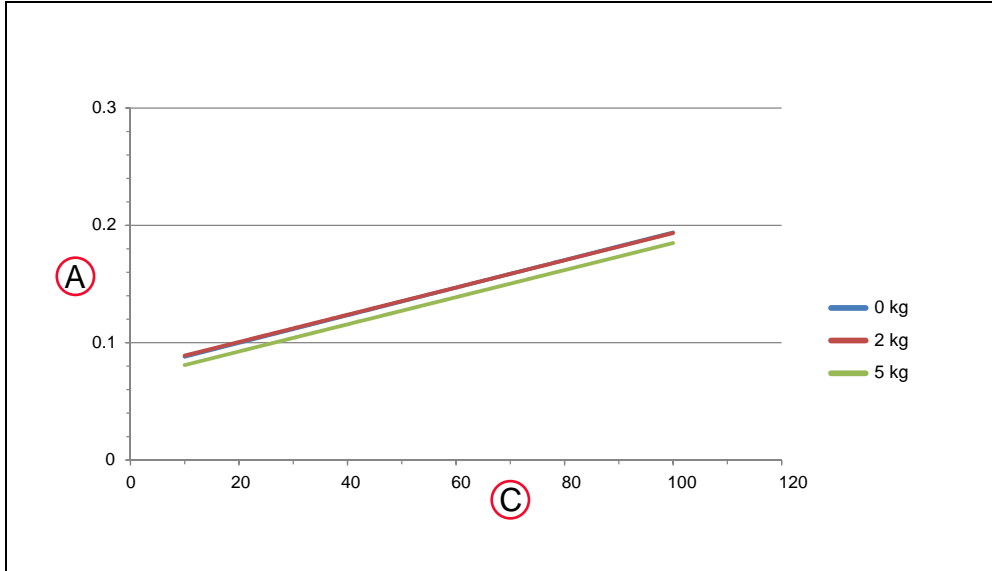

Figure 13-13. Joint 2 Stopping Time for Cobra 450, in Seconds

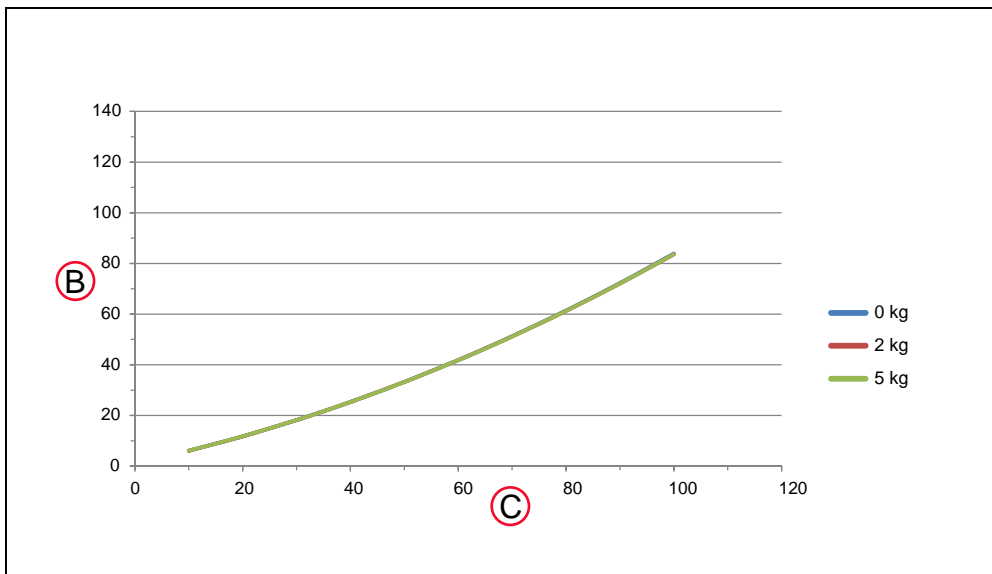

Figure 13-14. Joint 3 Stopping Distance for Cobra 450, in Millimeters

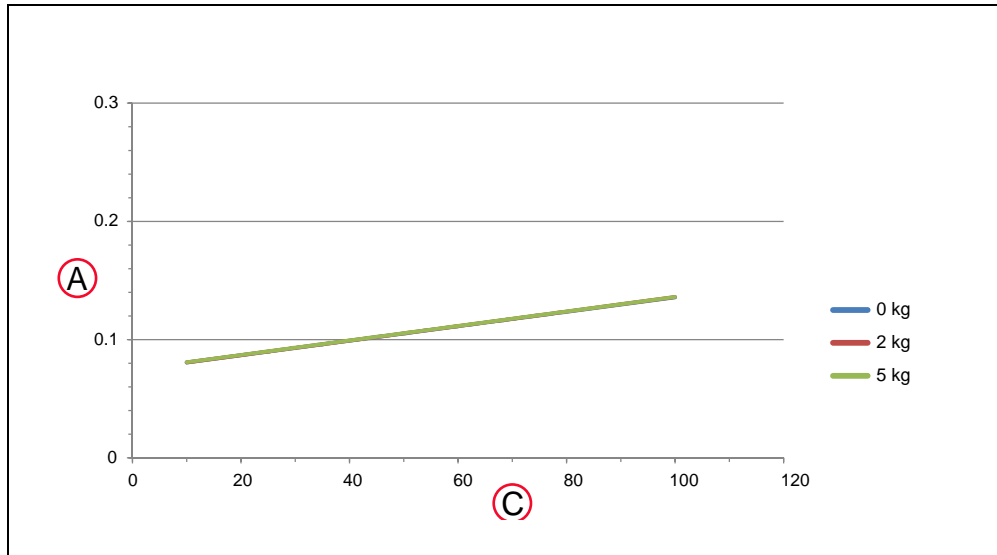

Figure 13-15. Joint 3 Stopping Time for Cobra 450, in Seconds

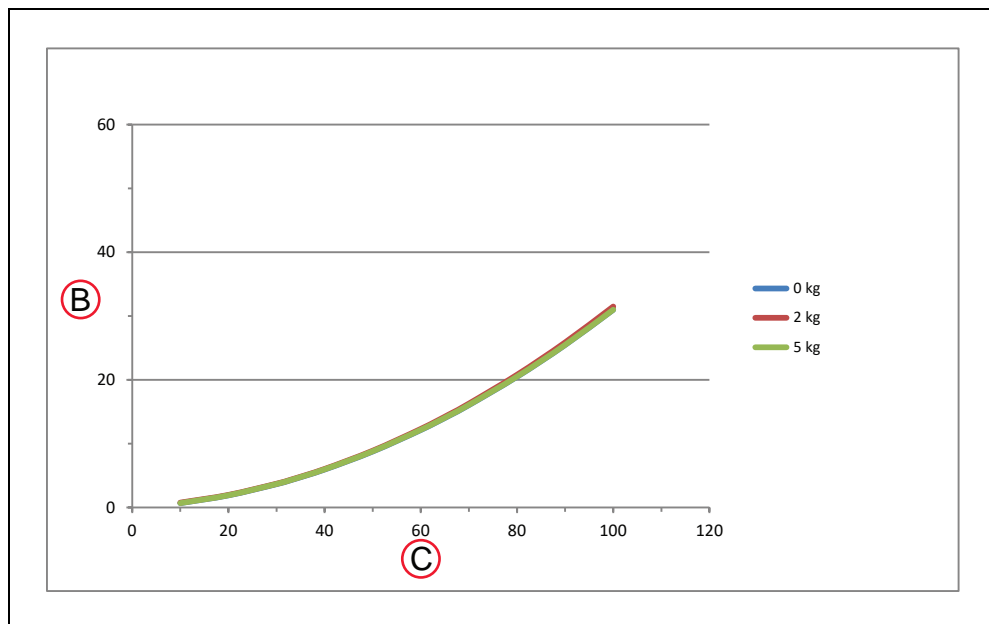

Figure 13-16. Joint 1 Stopping Distance for Cobra 500, in Degrees

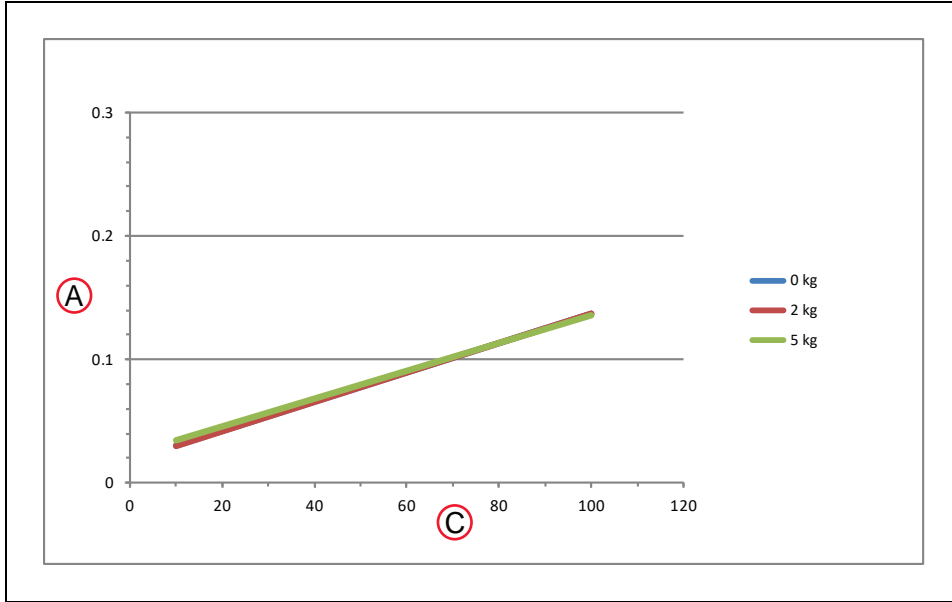

Figure 13-17. Joint 1 Stopping Time for Cobra 500, in Seconds

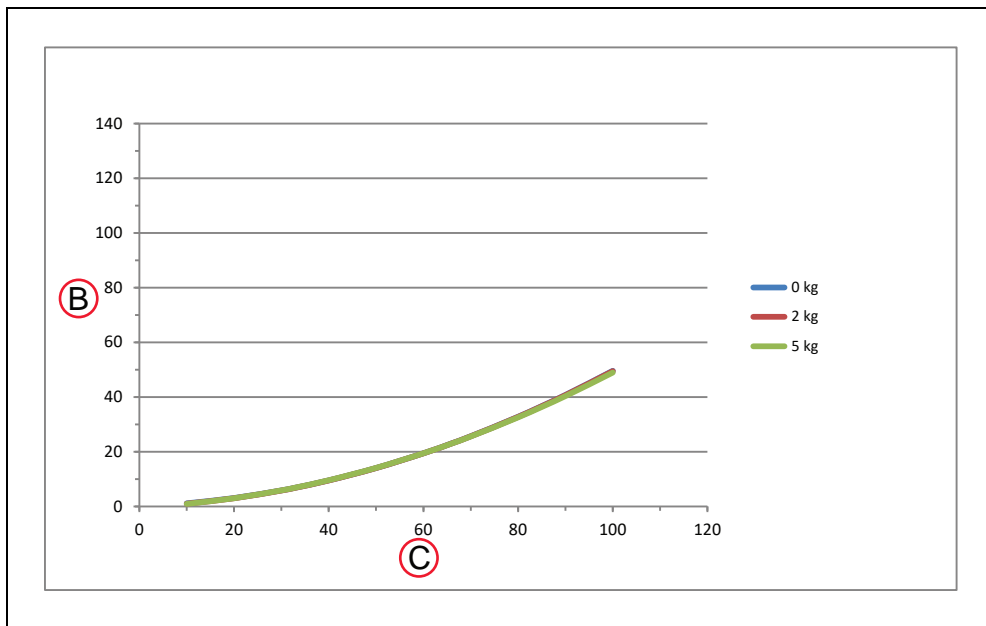

Figure 13-18. Joint 2 Stopping Distance for Cobra 500, in Degrees

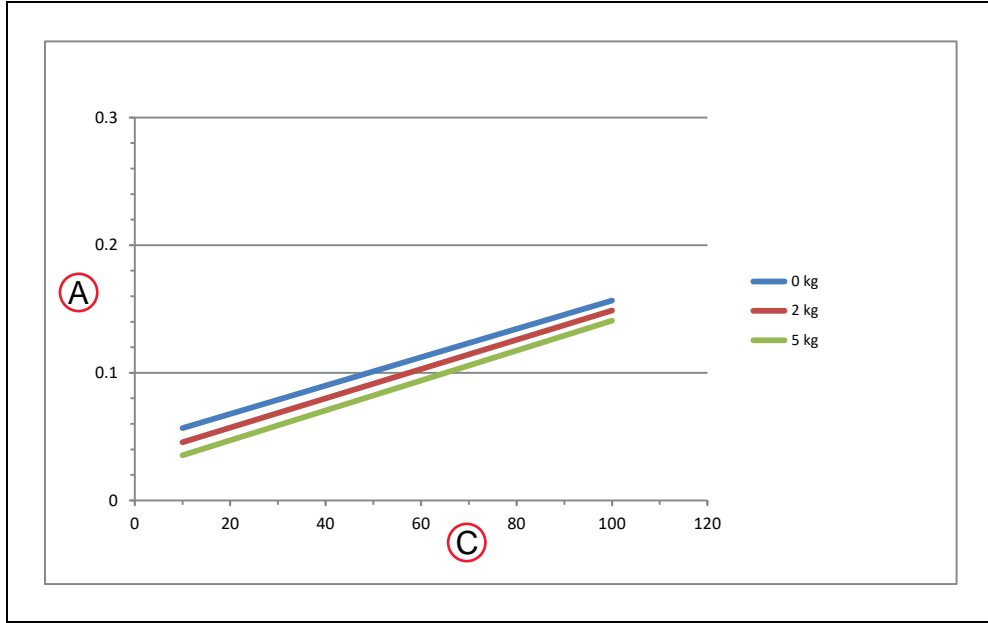

Figure 13-19. Joint 2 Stopping Time for Cobra 500, in Seconds

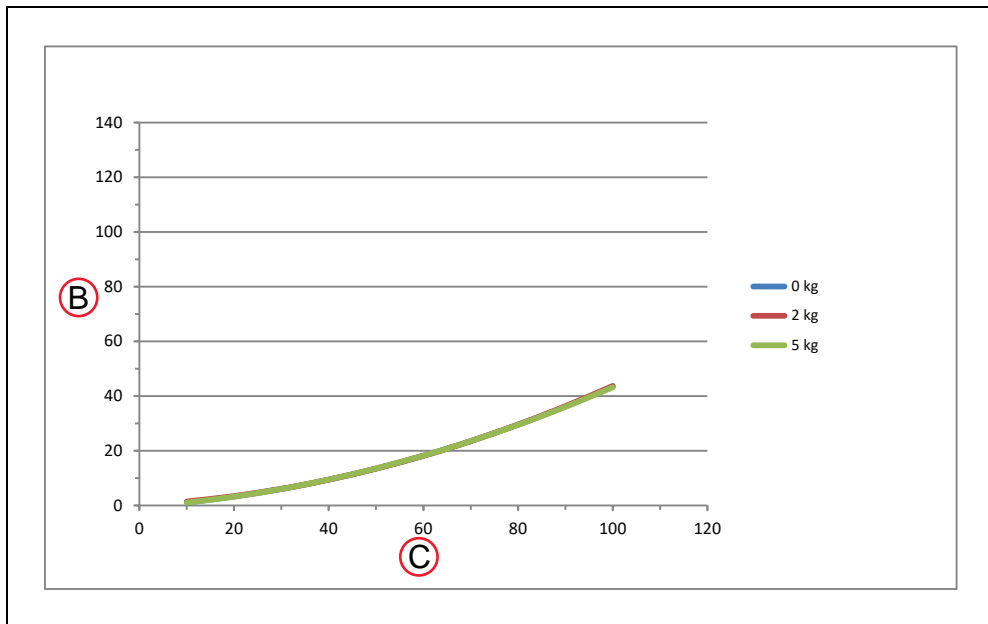

Figure 13-20. Joint 3 Stopping Distance for Cobra 500, in Millimeters

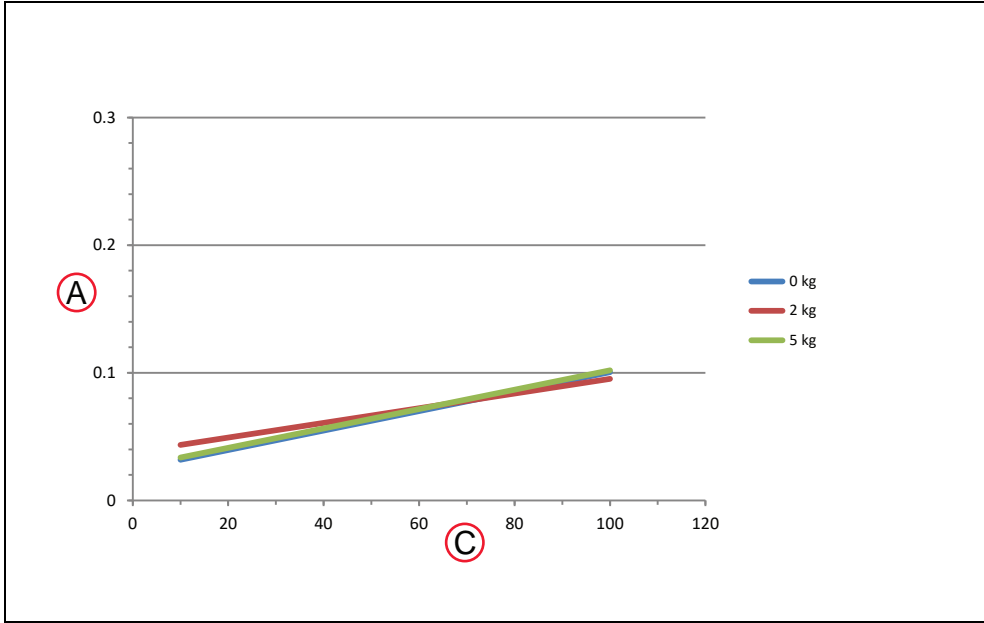

Figure 13-21. Joint 3 Stopping Time for Cobra 500, in Seconds

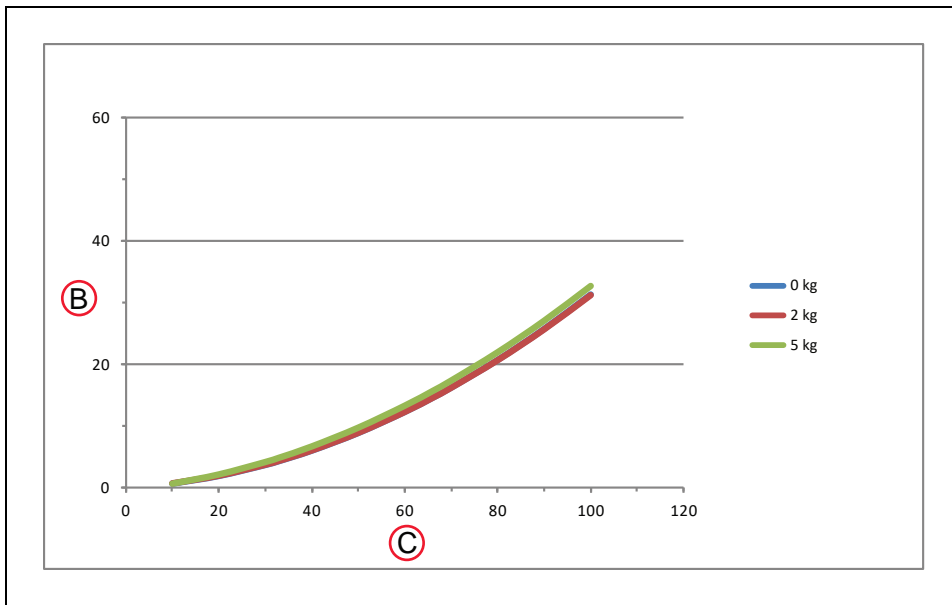

Figure 13-22. Joint 1 Stopping Distance for Cobra 650, in Degrees

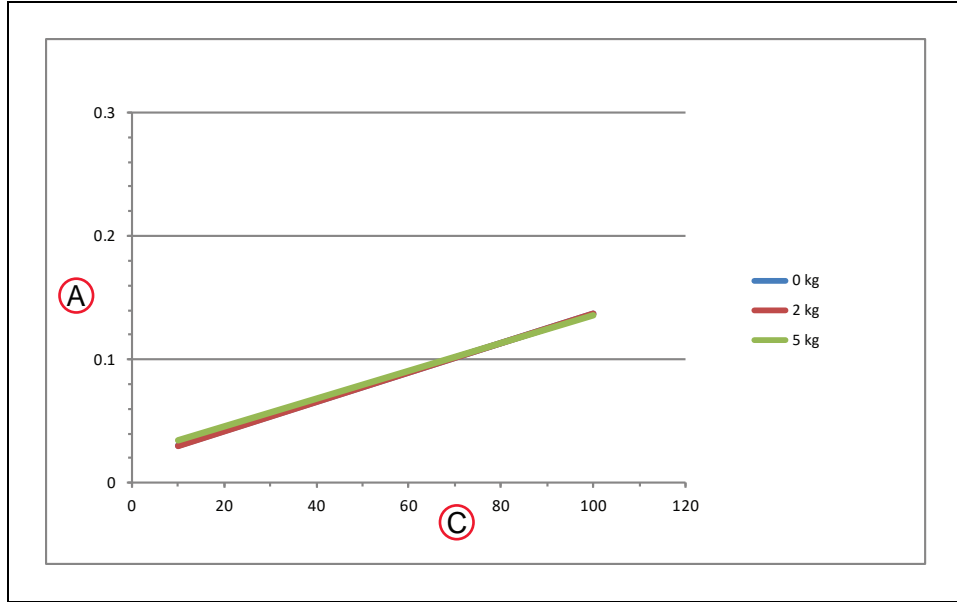

Figure 13-23. Joint 1 Stopping Time for Cobra 650, in Seconds

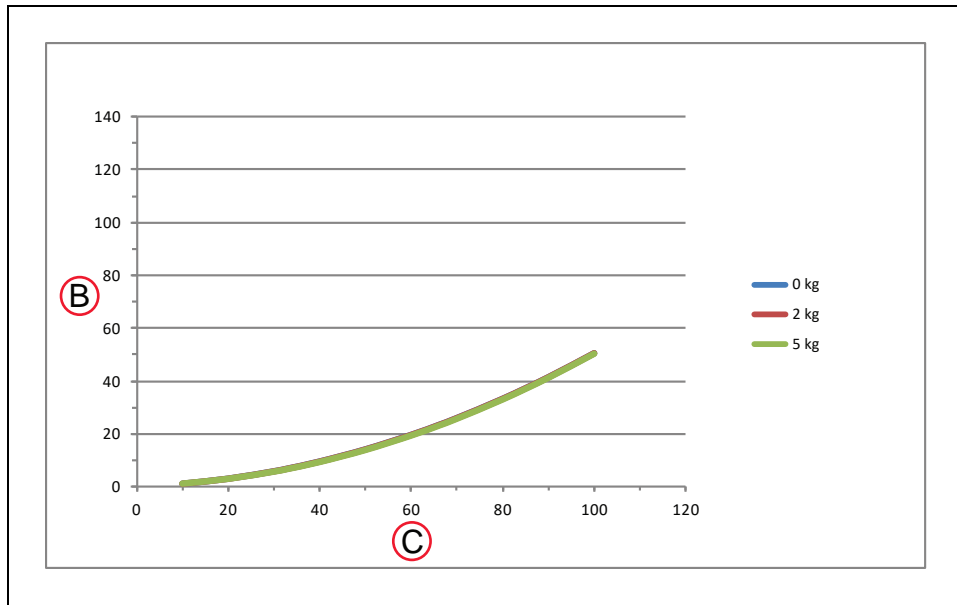

Figure 13-24. Joint 2 Stopping Distance for Cobra 650, in Degrees

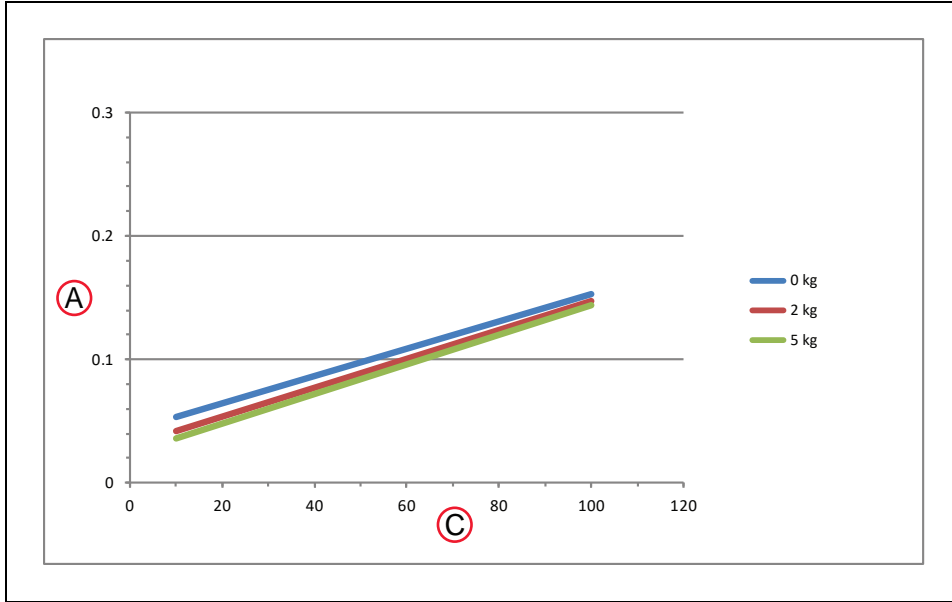

Figure 13-25. Joint 2 Stopping Time for Cobra 650, in Seconds

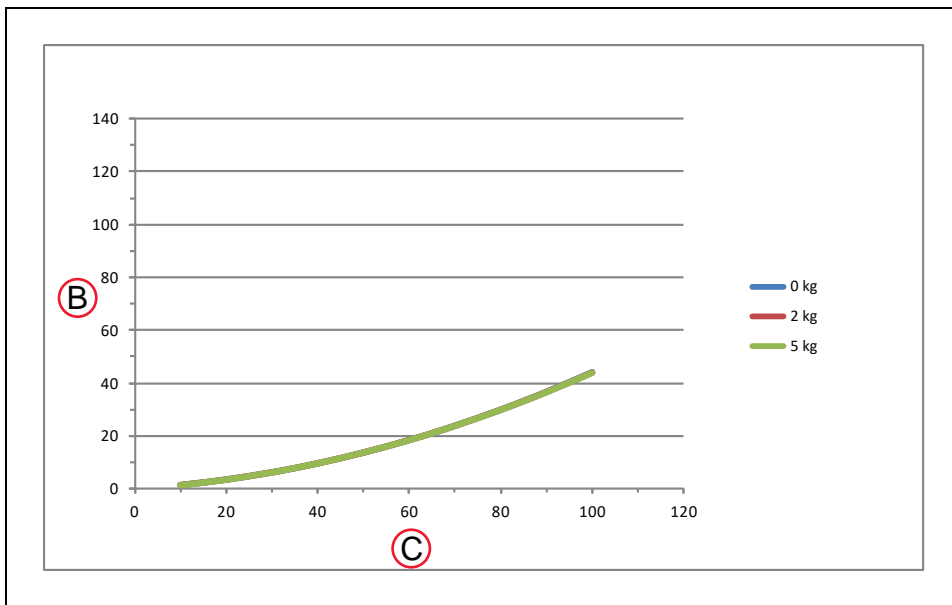

Figure 13-26. Joint 3 Stopping Distance for Cobra 650, in Millimeters

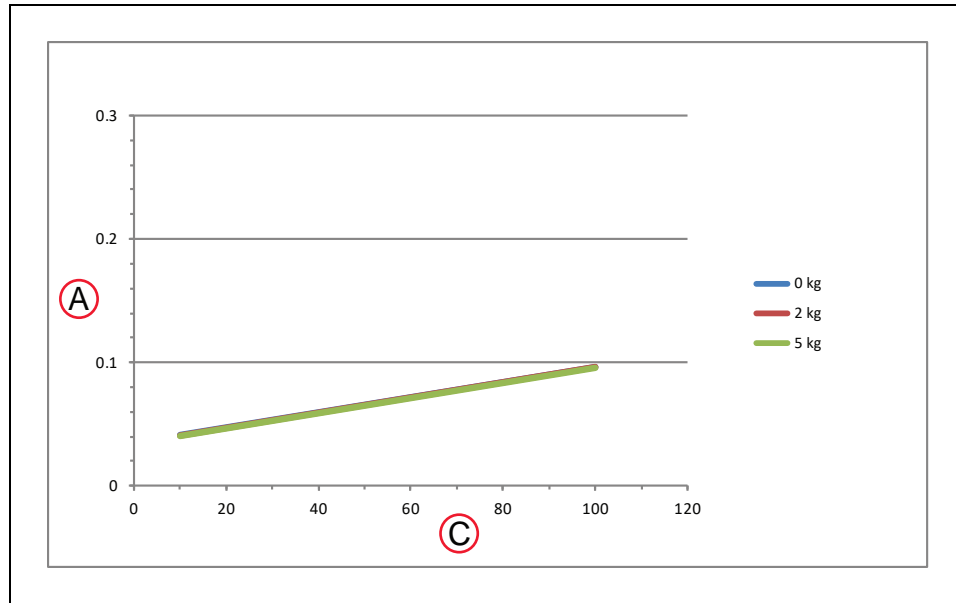

Figure 13-27. Joint 3 Stopping Time for Cobra 650, in Seconds

Stopping distances and times will not degrade as a result of either aging or normal use. Stopping distance will vary only if there is an actuating mechanism failure, which may require replacement of the failed component.

If an integrator wants to perform their own measurement of stopping distances and time in a real cell with a real robot and with real tools and loads, contact your local Omron support.

OMRON Corporation Industrial Automation Company
Kyoto, JAPAN

Contact: www.ia.omron.com

Regional Headquarters

OMRON EUROPE B.V.
Wegalaan 67-69, 2132 JD Hoofddorp
The Netherlands
Tel: (31)2356-81-300/Fax: (31)2356-81-388

OMRON ELECTRONICS LLC
2895 Greenspoint Parkway, Suite 200 Hoffman Estates,
IL 60169 U.S.A.
Tel: (1) 847-843-7900/Fax: (1) 847-843-7787

OMRON ASIA PACIFIC PTE. LTD.
No. 438A Alexandra Road # 05-05/08 (Lobby 2),
Alexandra Technopark,
Singapore 119967
Tel: (65) 6835-3011/Fax: (65) 6835-2711

OMRON ADEPT TECHNOLOGIES, INC.
4550 Norris Canyon Road, Suite 150, San Ramon, CA 94583 U.S.A.
Tel: (1) 925-245-3400/Fax: (1) 925-960-0590

OMRON (CHINA) CO., LTD.
Room 2211, Bank of China Tower, 200 Yin Cheng Zhong Road,
PuDong New Area, Shanghai, 200120, China
Tel: (86) 21-5037-2222/Fax: (86) 21-5037-2200

Authorized Distributor:

© OMRON Corporation 2018-2019 All Rights Reserved. In the interest of product improvement, specifications are subject to change without notice.

Printed in USA

0319 (0118)

Cat. No. I832-E-04

19148-000 G