

## **Palletizing Solution**



## Table of Contents

<b>Introduction</b>	<b>3</b>
I.1 Document identification	4
I.2 Scope and Purpose	4
I.3 Intended use	4
<b>Feature Components</b>	<b>5</b>
II Overview of the product	6
II.1 BCK HOLLAND RD50 Conveyor	6
II.1.1 Control System	7
II.1.2 SENSOPART F 18-2.W K4 - Conveyor sensor	8
II.2 Vacuum gripper - FXP-SVK 442 3R54 SPB2-40P	8
II.2.1 VSi V M8-4 Vacuum/pressure switch	11
III Ovi Palletiser URCap	12
III.1 Software requirements	13
III.2 Installation	13
III.3 Features	13
III.4 Usage	13
IV Ovi Palletiser URP	18
IV.1 Software requirements	18
IV.2 Installation	18
IV.3 Features	18
IV.4 Usage	19
V Ovi Pattern Maker	19
V.1 System requirements	19
V.2 Installation	19
V.3 Features	20
V.4 Usage	20

# I. Introduction

## I.1 Document identification

This appendix to the **OVI** user manual contains information about the **OVI palletizing** solution. It must be read and understood by the integrators/end clients of OVI before the system is powered on for the first time.

It is mandatory to follow all instructions and guidance provided in this appendix.

## I.2 Scope and Purpose

The appendix provides a general product overview and description of the design, functionality, and basic operation and instructions of **Ovi Palletiser**.

This document is aimed at users with the following knowledge and skills:

- Basic knowledge of mechanical engineering;
- Basic knowledge of electrical and electronic systems;
- Knowledge of the Universal Robots programming concepts.

## I.3 Intended use

Use is only permitted after performing a risk assessment for the complete robot system.

The complete system needs to be installed in accordance with the safety requirements specified in the standards and regulations of the country where it is installed.

Interfacing other machines is permitted only after the integrator eliminates any significant hazard that does not respect safety regulations.



### **NOTE:**

Changing the structure of the product, e.g. by drilling holes, etc. can result in damage to the components. This is considered improper use and leads to loss of warranty.

## II. Feature Components

## II Overview of the product

**Ovi Palletiser** is a quick setup palletizing solution that is easily integratable and allows users to define box arrangement patterns for a swift mode of palletizing, reducing commissioning time and human error. The package includes a conveyor, vacuum gripper, Ovi Palletiser URCap, URP, and Ovi Pattern Maker software.

### II.1 Conveyor

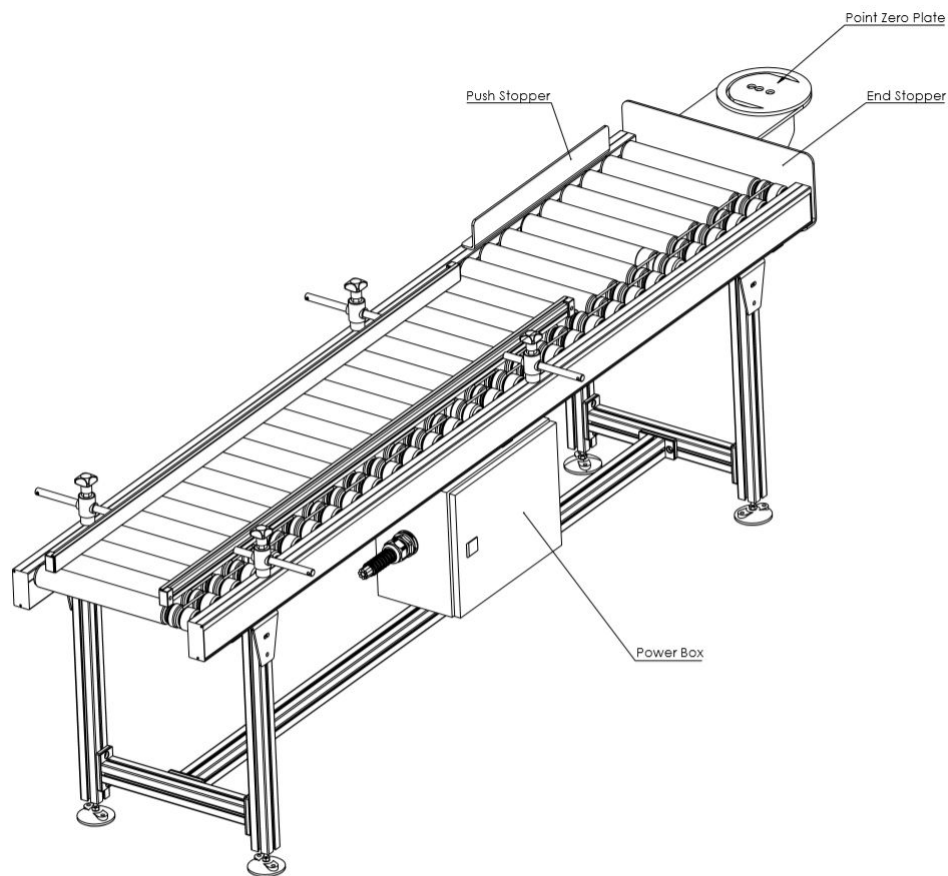

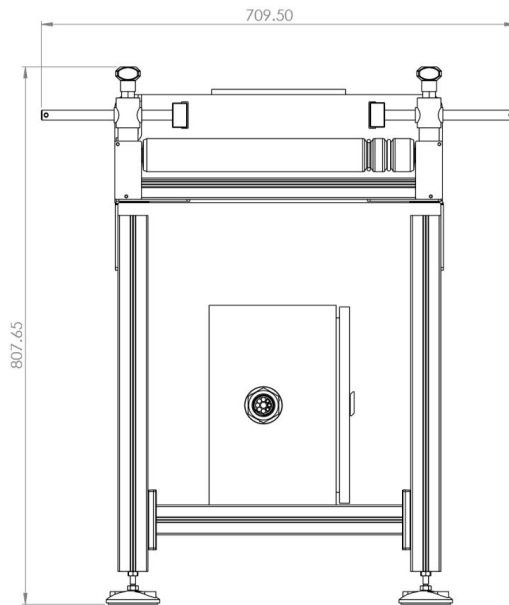
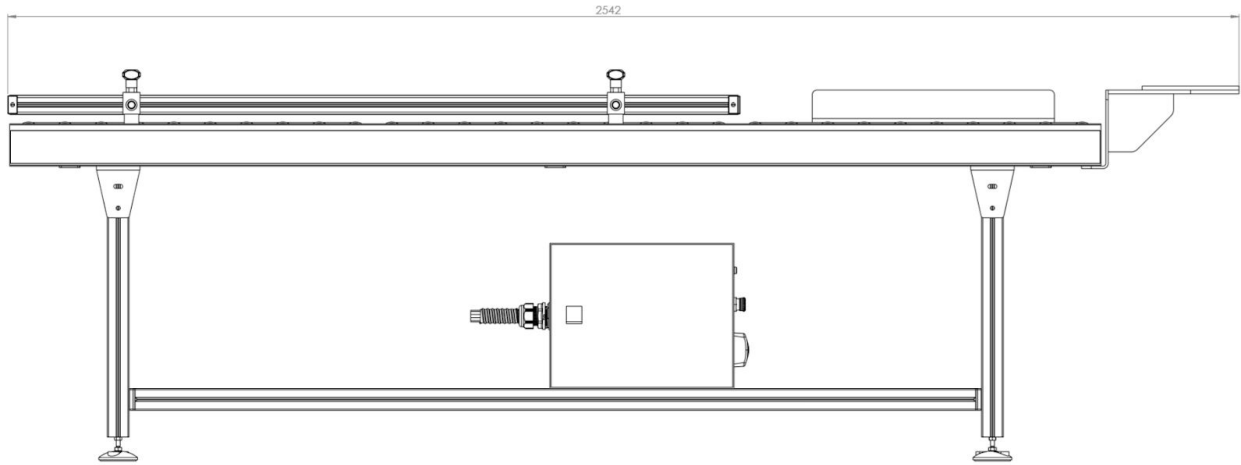



## II.2 Vacuum gripper

Vacuum area gripping system with integrated pneumatic vacuum generator and ball check valves.

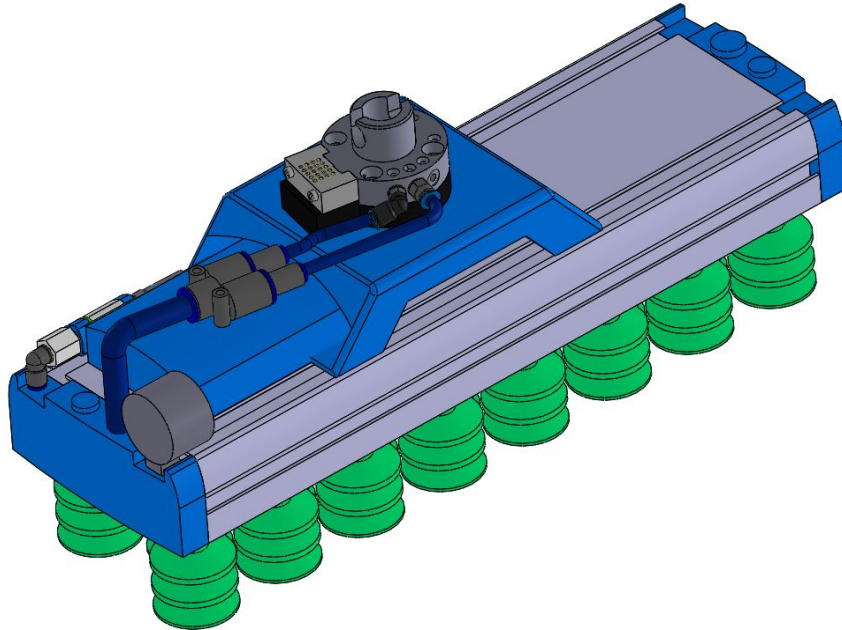

Item	Value	Unit
<b>Overall dimensions</b>		
- Length L	442	[mm]
- Width	130	[mm]
- Height	195	[mm]
<b>Arrangement:</b>	3 rows, 54mm	
<b>Suct. cups</b>	Bellows suction cup SPB2	
- Diameter Ds	40	[mm]
- Shape	Push in with multi-stage ejector SEMP 50	
<b>Air consumption</b>	250	[l/min]
<b>Weight</b>	4.286	[kg]

### Design Data

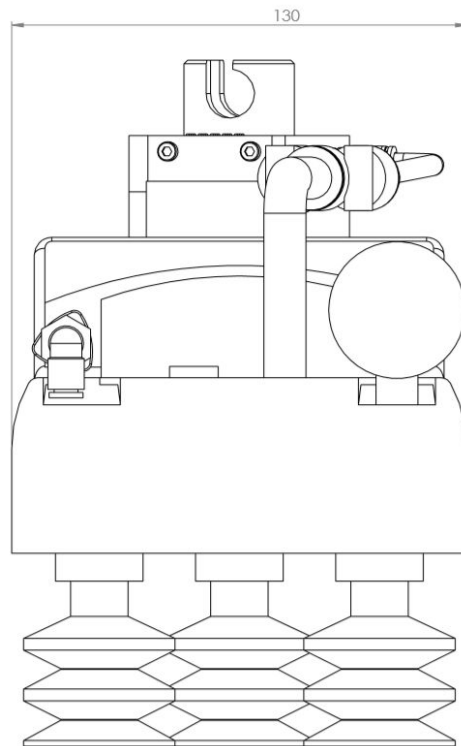
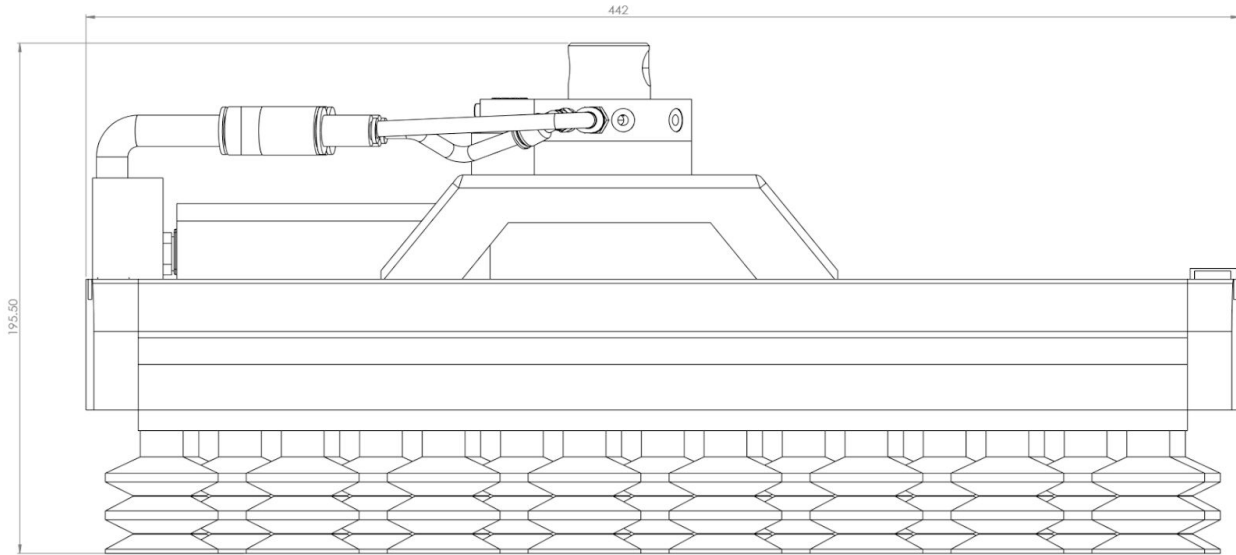

## Technical Data

<b>Arrangement</b>	3R54	
<b>Suction force</b>	250	[N]
<b>Suction rate (max.)</b>	1,050	[l/min]
<b>Air consumption</b>	250.0	
<b>Sealing element</b>	Suction Cups	
<b>Weight</b>	2.8	[ kg ]
<b>Sound level</b>	74	[dB] Max. degree of evacuation 55%

### II.2.1 Vacuum/pressure switch

Vacuum and pressure switch with two digital output signals and IO-Link function.



<b>Measuring range</b>	-1...0 bar
<b>Electrical connection</b>	Male connect M8, 4 pole
<b>Indication</b>	LED
<b>Protection</b>	IP 65

## Design Data

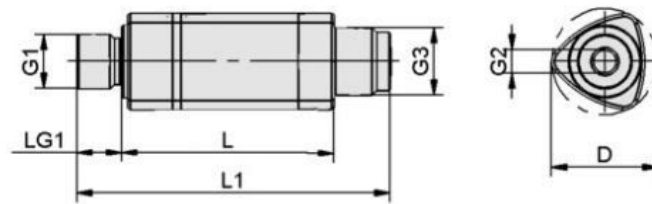

<b>D</b>	19.6	[mm]
<b>G1</b>	G1/8"-M	
<b>G2</b>	M5-F	
<b>G3</b>	M8x1-M	
<b>L</b>	38	[mm]
<b>L1</b>	55	[mm]
<b>LG1</b>	8	[mm]

## Technical Data

Attribute	Value	Unit
<b>Measured</b>	Non-aggressive gases; dry, oil-free air	
<b>Overpressure resistance</b>	8	[bar]
<b>Voltage</b>	10-30	[V] DC
<b>Switching capacity (max)</b>	100	[mA]
<b>Inputs/outputs</b>	LED	
<b>Current consumption</b>	35	[mA]

## III Ovi Palletiser URCap

The URCap contains functionalities that allow the UR10 robot arm to perform the desired palletising procedure. It allows the user to load palletising pattern files, transfer information stored in the pattern file to the program interface, and continually checks that the proper tool is connected before performing any palletising action.

### III.1 Software requirements

Ovi URCap

### III.2 Installation

The Ovi Palletiser URCap can be installed following the same installation procedure as any other URCap.

1. Navigate to the URCap setup screen: Settings -> URCaps;
2. Click the button labeled "+";
3. Navigate to the location of the .urcap file;
4. Select the desired file;
5. Press "Open";
6. Restart the robot to finish the installation.

### III.3 Features

1. Load files containing palletising pattern;
2. Display loaded pattern information;
3. Detection of vacuum gripper tool;
4. Turn the air pump on/off.

## III.4 Usage

### Step 1: Load pattern file

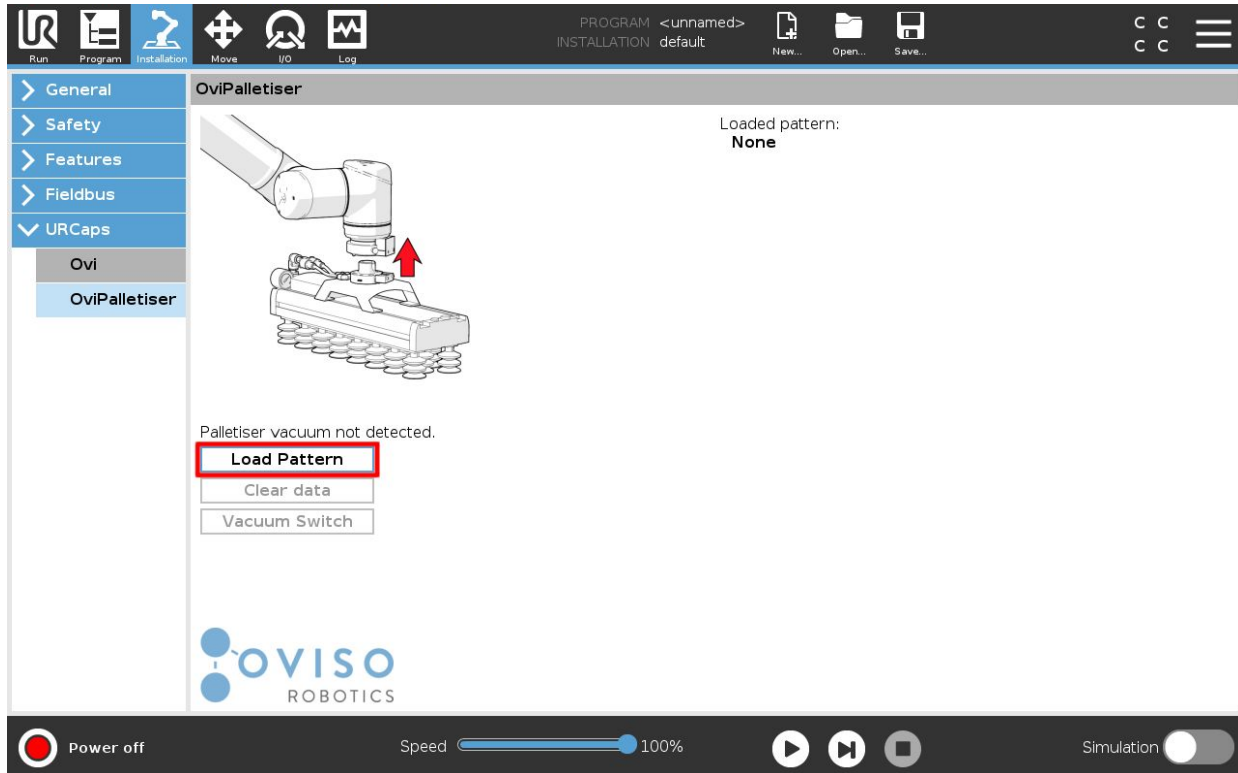

An XML file containing a palletising pattern can be loaded by pressing the “Load Pattern” button on the left hand side of the user interface (UI).

This will launch a window where the user can navigate to the desired pattern file.

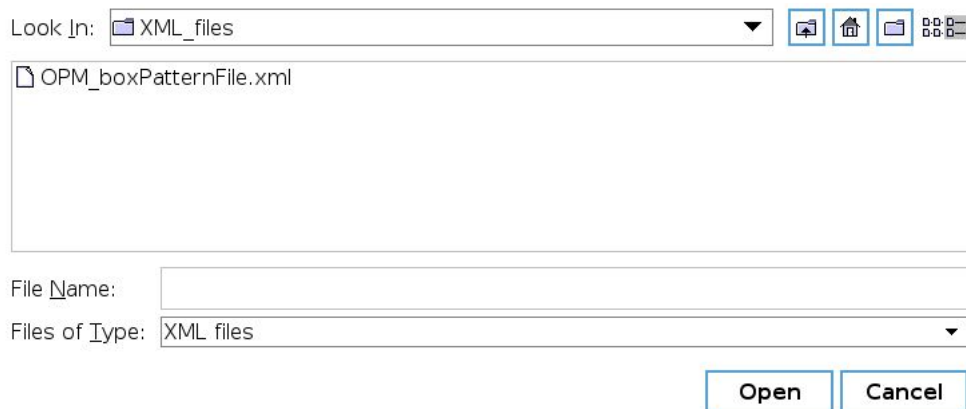

When the file has been selected, click “Open” to load it.

After this has been completed, the name of the selected file is displayed on the right hand side of the UI as well as the values of the parameters contained in the file.

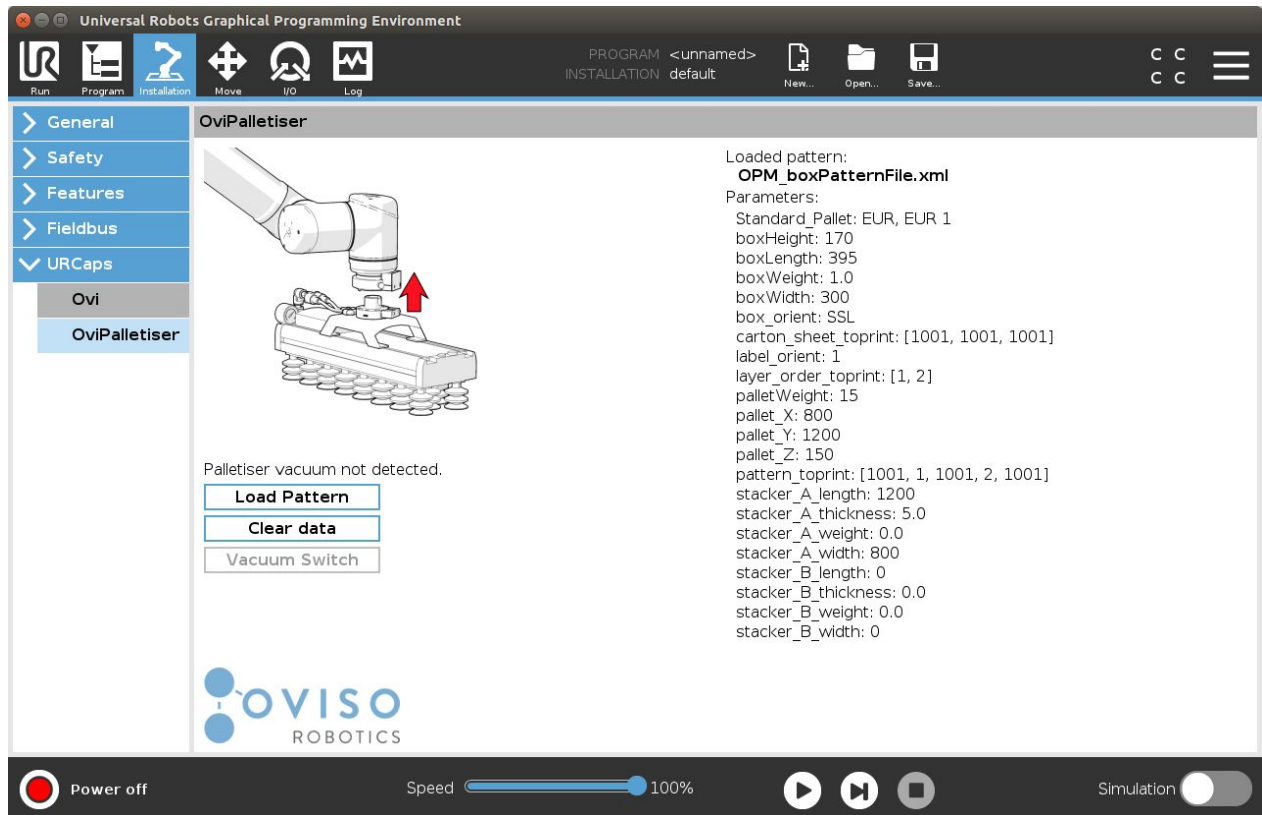

## Step 2: Tool check

The image displayed on the top left of the UI indicates if the vacuum gripper tool is connected or not.

Before the vacuum gripper tool is connected:

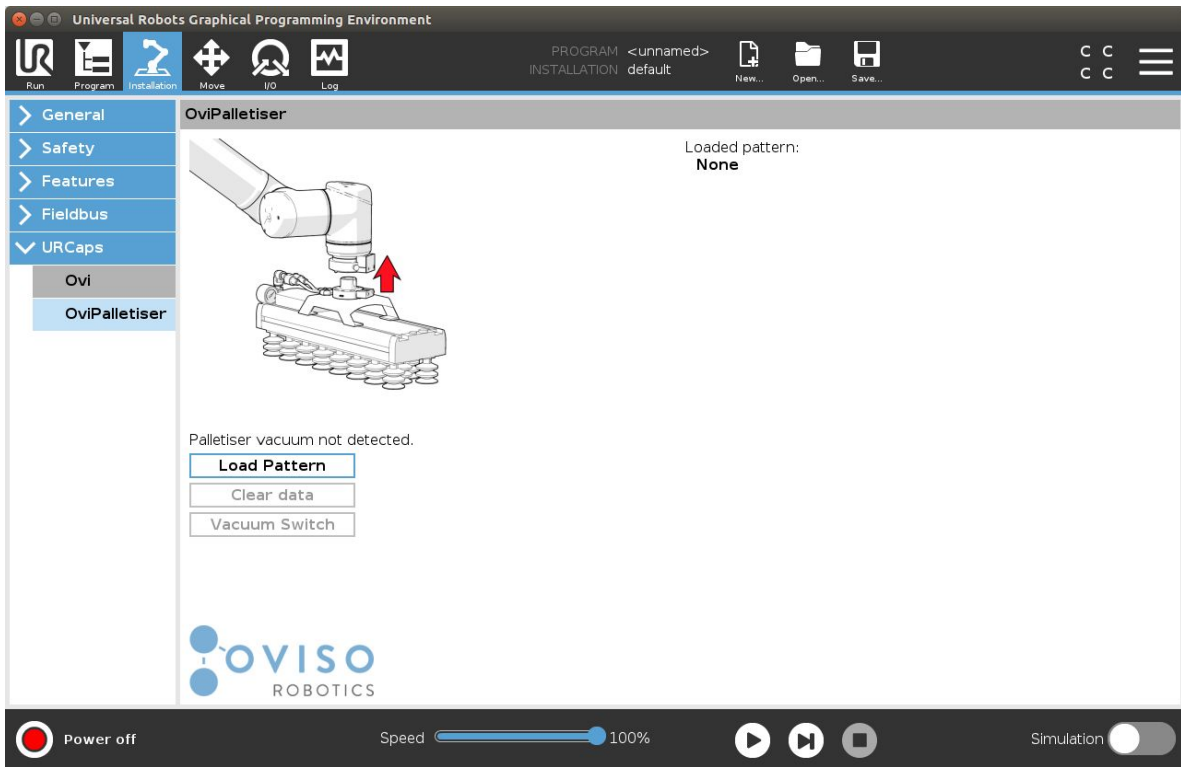

After the vacuum gripper tool is connected:

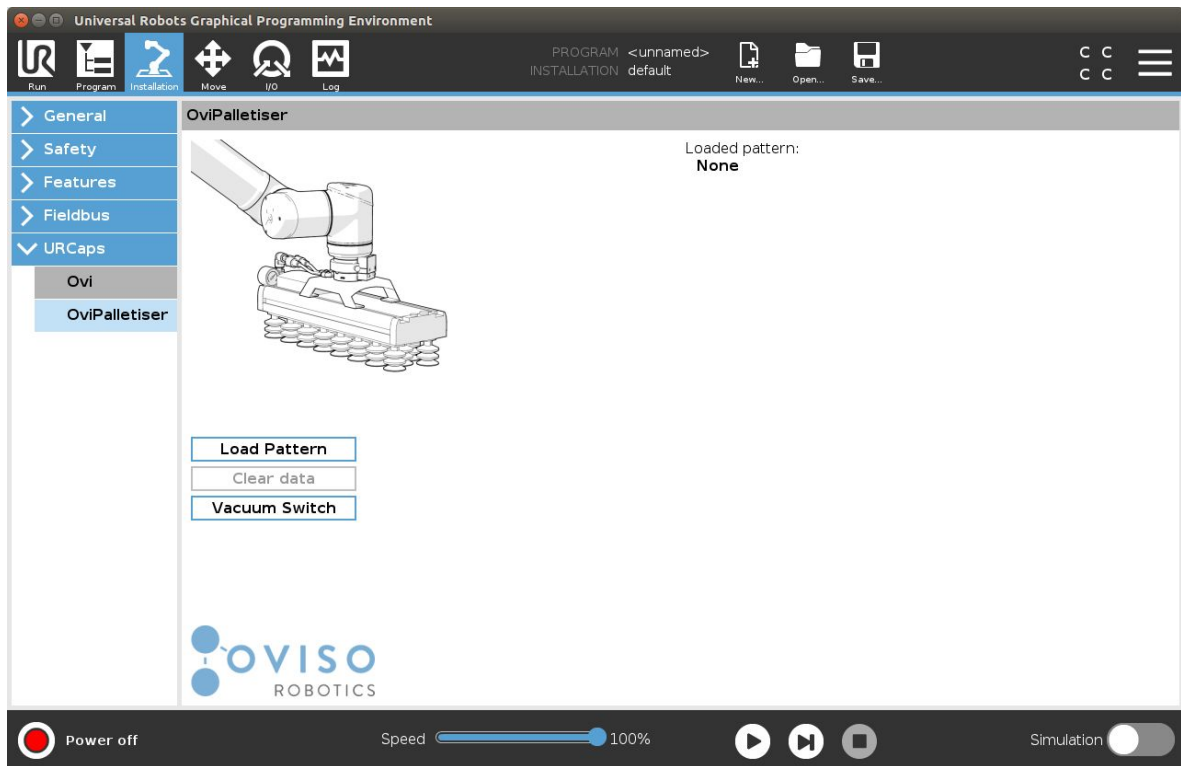



### Step 3: Turn air pump on/of (optional)

While the vacuum gripper tool is connected the URCap detects its presence and enables the “Air pump” button.

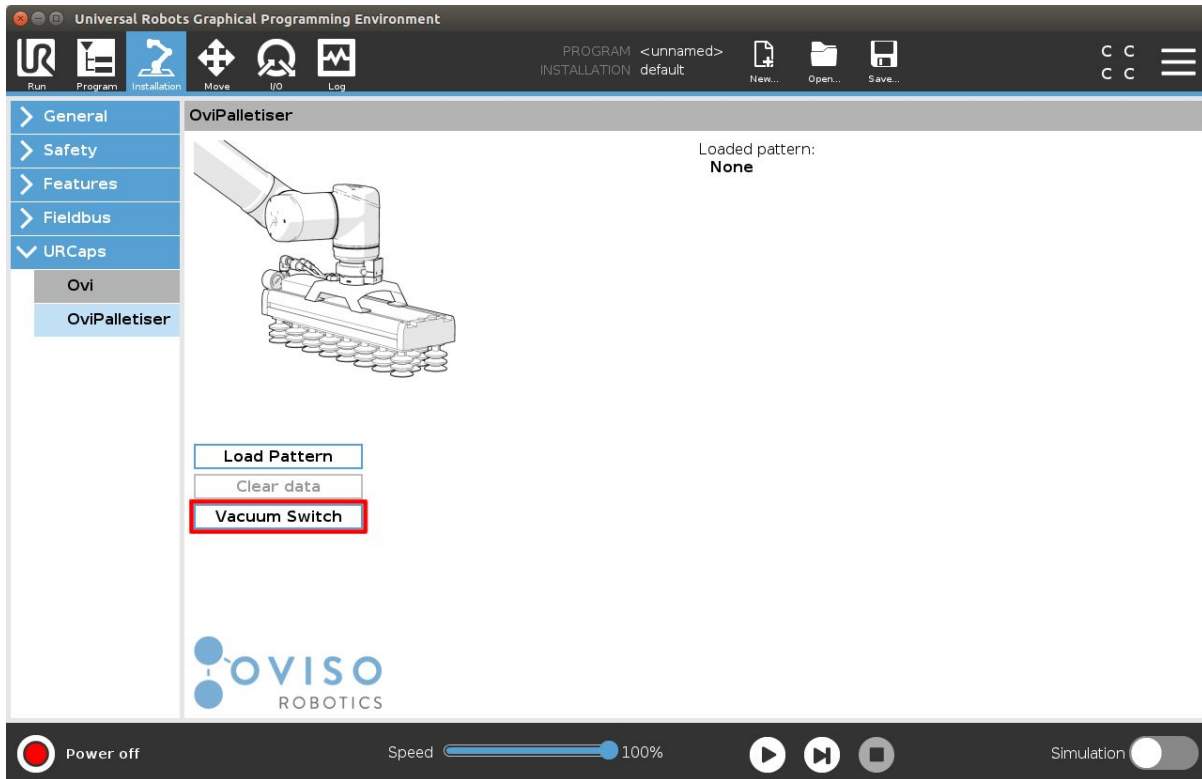

This button may now be clicked in order to activate air flow to the tool, and clicked again in order to deactivate it. The top left image changes according to the status of the air flow.

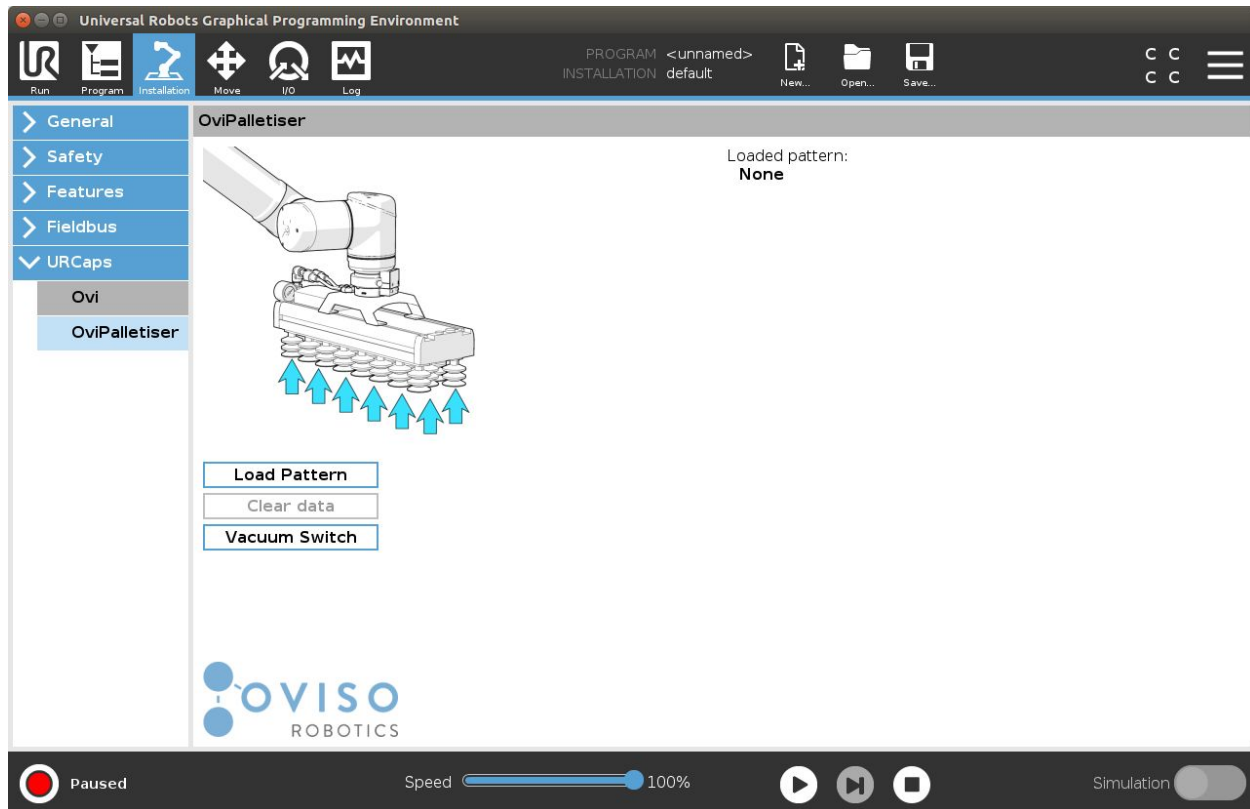

## IV Ovi Palletiser URP

The Ovi Palletiser URP makes use of the functionalities implemented by the URCap and contains the commands that move the robot to the appropriate place in order to complete the palletising pattern generated within the provided OPM XML file. The URP perfectly integrates the functionality of PointZero adjusting the placement of each box with respect to the last recorded PointZero coordinates.

### IV.1 Software requirements

OviPalletiser URCap

### IV.2 Installation

There is no installation required for this step. The user simply has to load the URP provided with the palletising package in the Polyscope interface of the UR robot.

### IV.3 Features

- PointZero: waypoints are adjusted according to PointZero coordinates allowing the robot to self-calibrate after its position has changed;
- Stop/Resume palletising process: if the palletising process was interrupted, the user is able to resume the operation from the point where the interruption occurred;
- Pallet detection: The frame is fitted with presence sensor on each side which inform the operator if a pallet is present or absent;
- Signal light activation: the frame is also fitted with a signal light which signals the completion of the palletising operation to the user.

### IV.4 Usage

**Step 1:** Load the URP by clicking “Open” in the Polyscope interface.

**Step 2:** Make sure that an OPM xml pattern file is loaded in the OviPalletiser URCap view.

**Step 3:** Press the play button in order to start the palletising process.

### V Ovi Pattern Maker

The Ovi Palletiser package contains the Windows/Linux application Ovi Pattern Maker, which helps the integrator/client to configure the palletizing pattern, in less than 5 minutes.

#### V.1 System requirements

Windows (7 or greater, x86 or x64), Linux (32 bit or 64 bit).

#### V.2 Installation

Ovi Pattern Maker requires no installation. To launch the application simply run the executable named “opm” IN Windows, or run navigate to the OPM folder and run “./opm” command from a terminal in Linux.

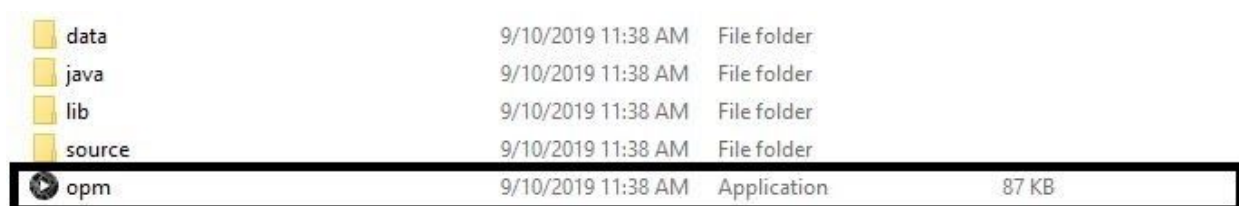

data	9/10/2019 11:38 AM	File folder	
java	9/10/2019 11:38 AM	File folder	
lib	9/10/2019 11:38 AM	File folder	
source	9/10/2019 11:38 AM	File folder	
opm	9/10/2019 11:38 AM	Application	87 KB

### V.3 Features

The Ovi Pattern Maker features are:

1. Possibility to choose a predefined pallet size or to specify a custom pallet;
2. Specify box configuration;
3. Choose label orientation;
4. Configure the layers on a pallet, including possibility of adding sheets;
5. Choose number of boxes on each stroke;
6. Generate an XML file of the pattern;
7. Generate a PDF report file with the pattern.

### V.4 Usage

**Step 1:** When the Ovi Pattern Maker is launched, first of all the pallet type is chosen.

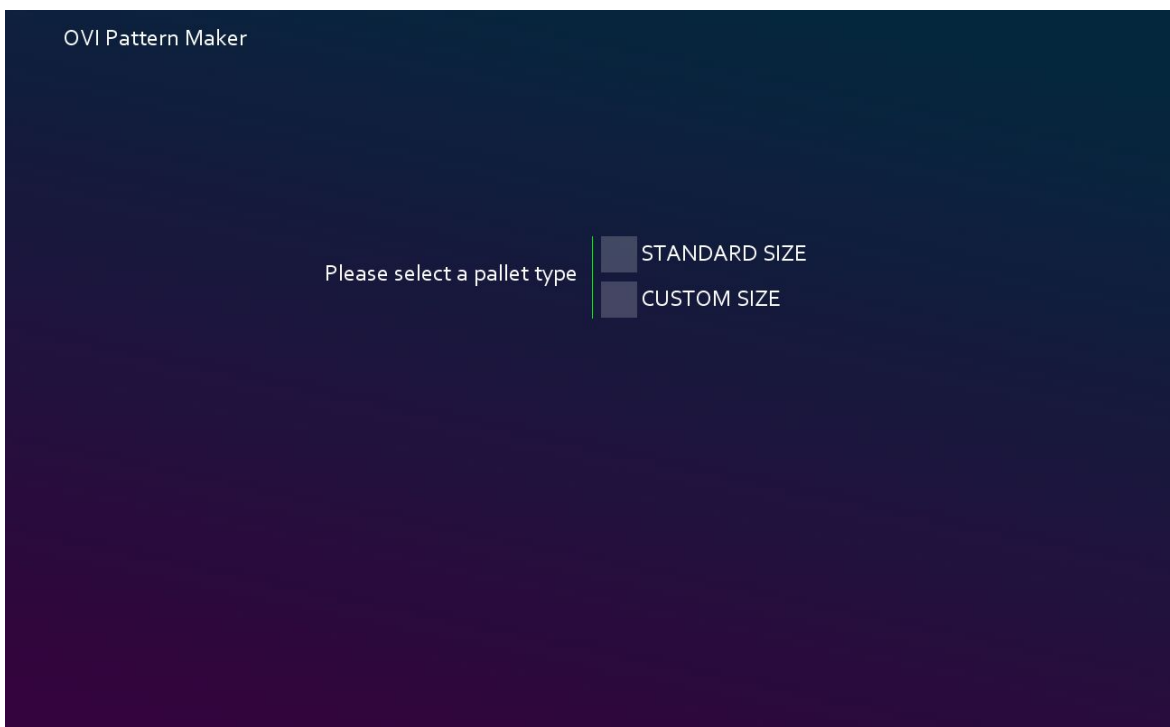

The pallet type can be STANDARD SIZE or CUSTOM SIZE. After selecting, a button labeled "NEXT" appears. Hit the button to move to the next step.

**Step 2:** For STANDARD SIZE a list of 6 pallet types will appear.

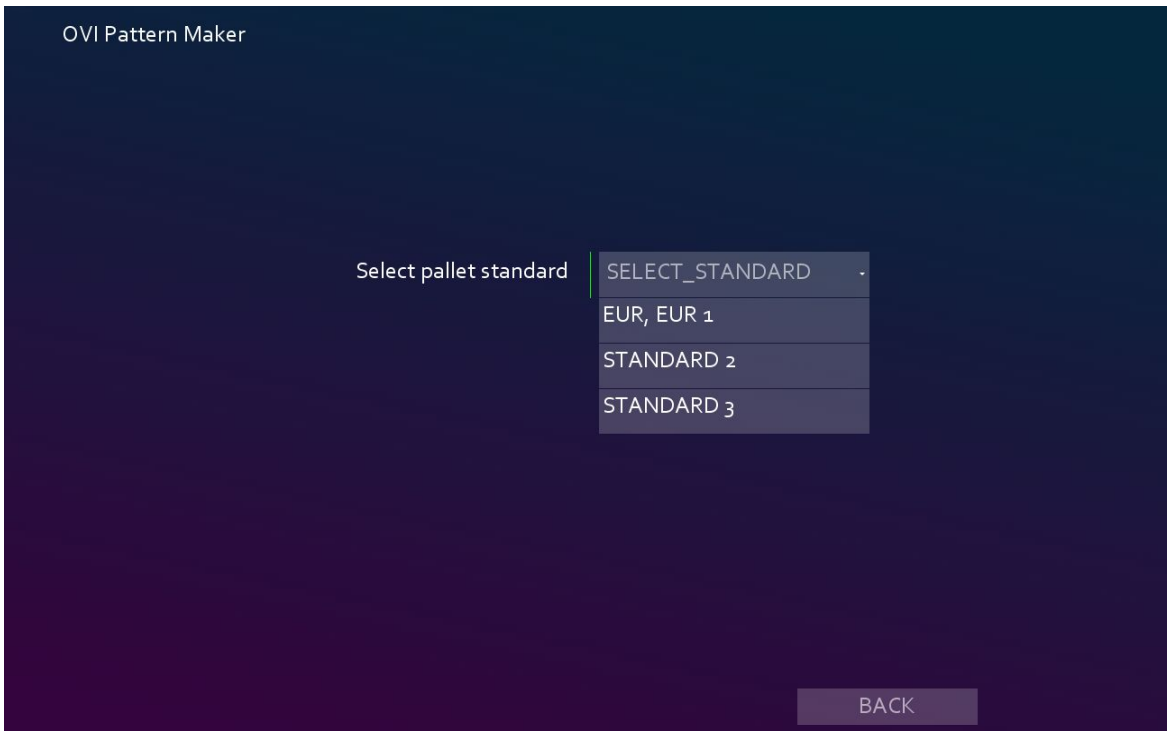

For CUSTOM SIZE the dimensions of the pallet are specified by the user. There are 3 fields which need to be filled out representing the width, length, and height of the pallet.

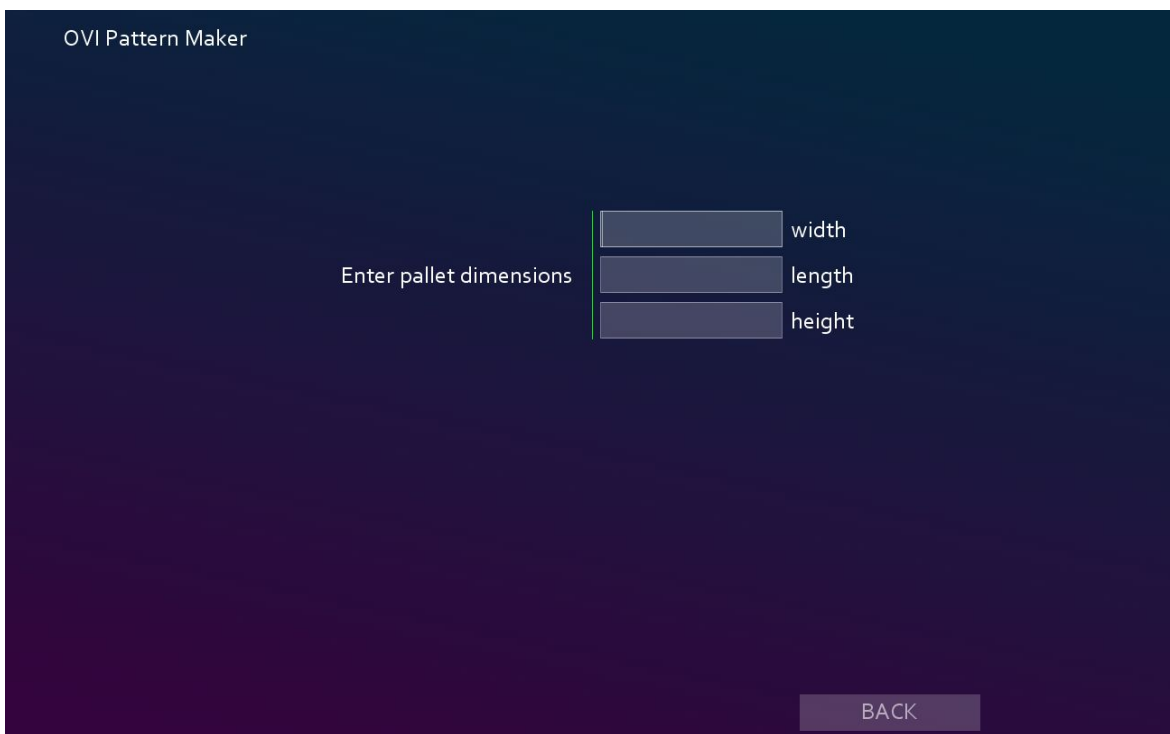

**Step 3:** After choosing the pallet, the next step is to configure the box by entering the length, width, height, and weight.

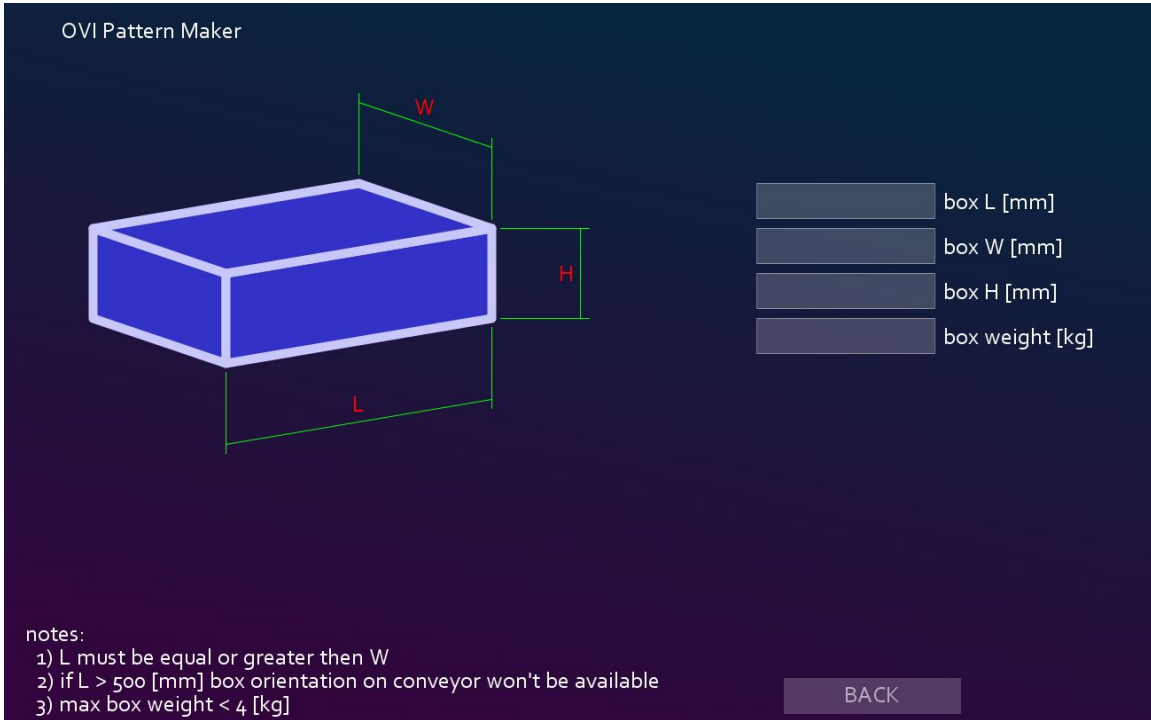

**Step 4:** Choose box orientation and label position.

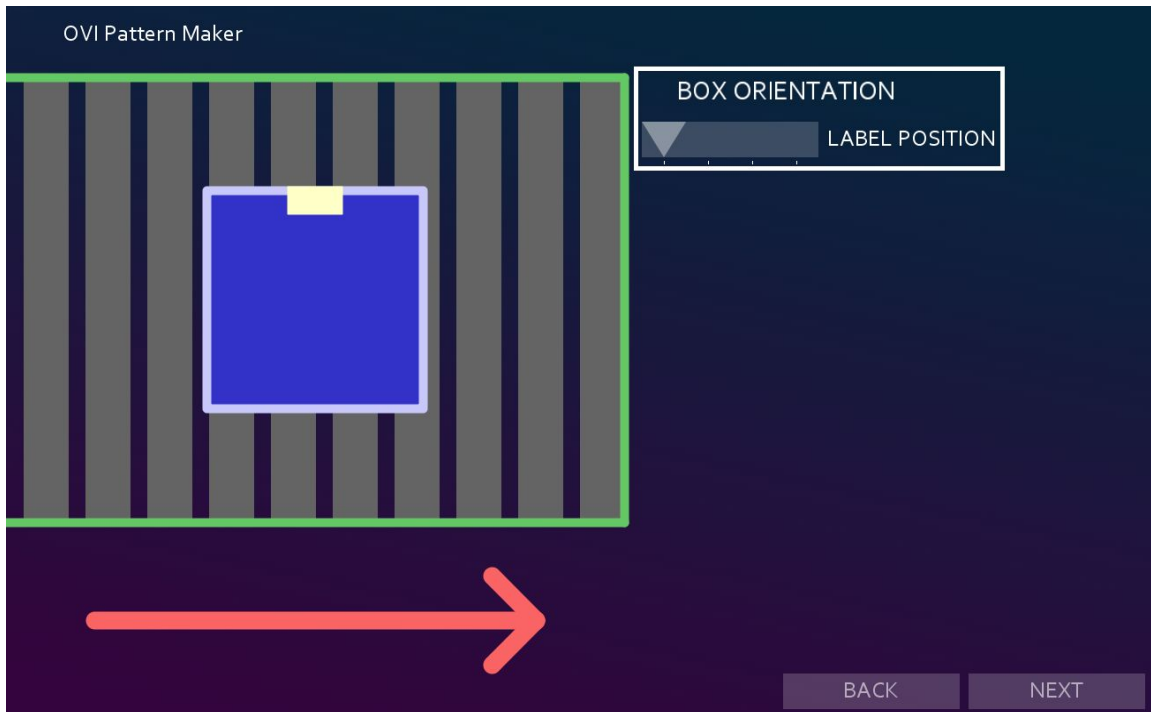

**Step 5:** Configure layers and choose if sheets will be added between layers.

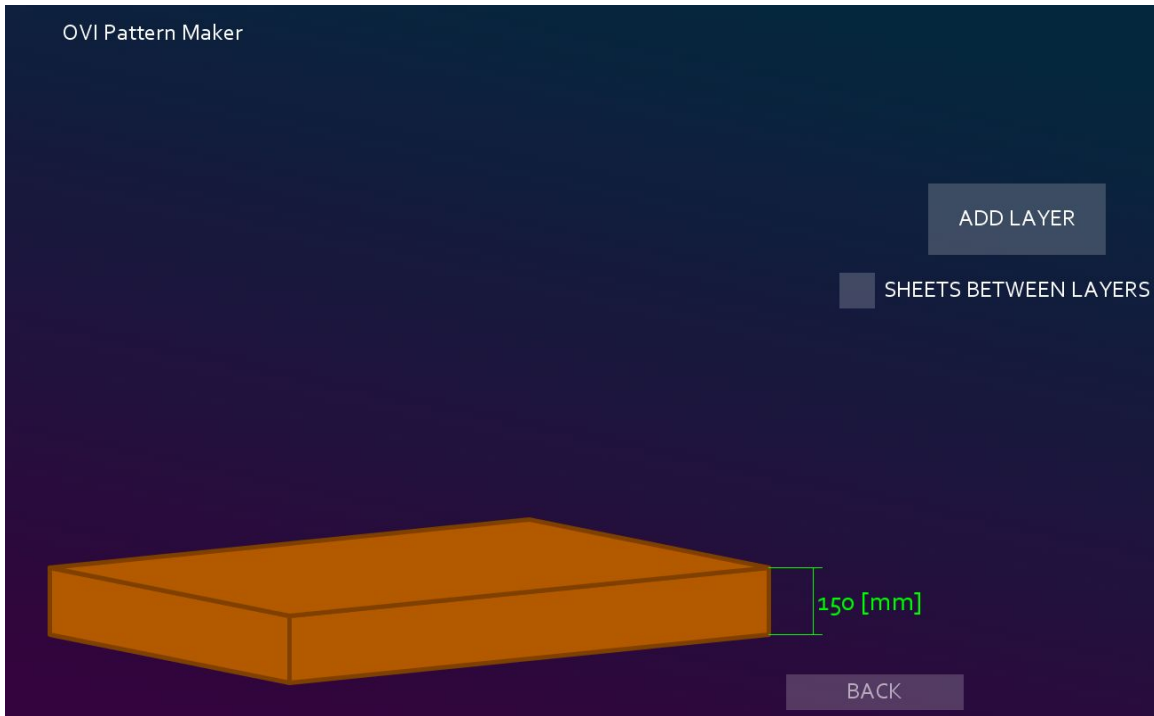

**Step 6:** Add the strokes on the first layer of the pallet.

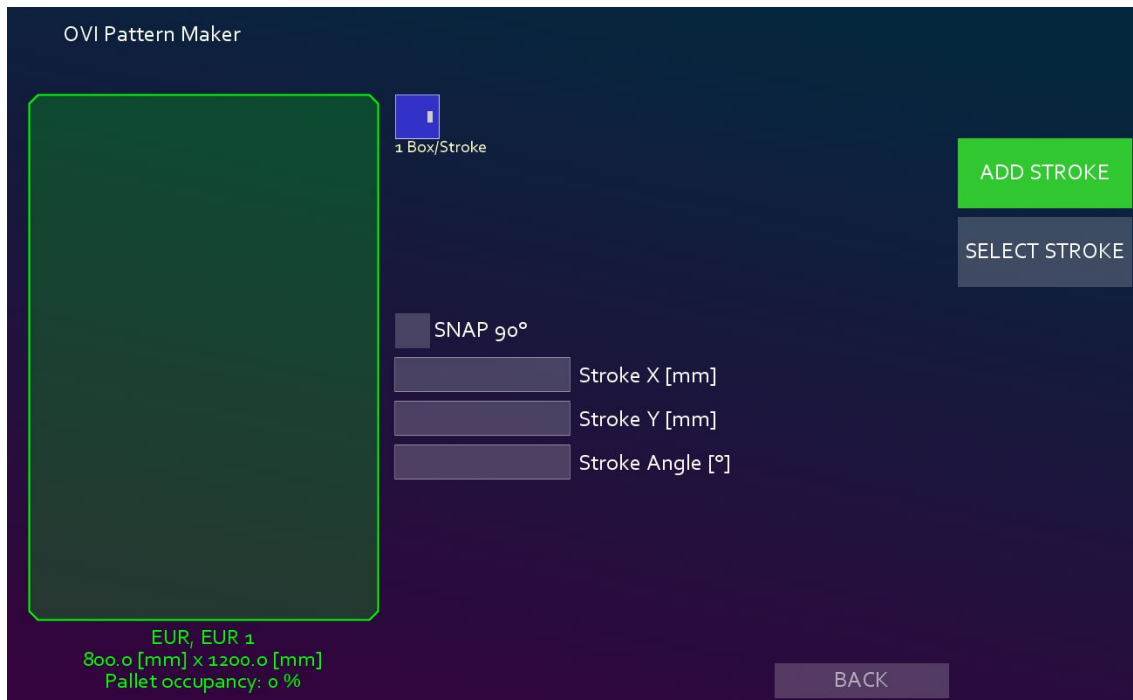

One or two boxes can be selected per stroke. Using the scroll button from the mouse, the boxes can be rotated. The "SNAP 90°" button allows the boxes to be rotated by exactly 90°.

Bellow is an example of a pattern:



**Step 7:** The pattern can be edited by pressing the "SELECT STROKE" button and then clicking on an existing stroke (box or group of boxes) from the pattern on the left side.



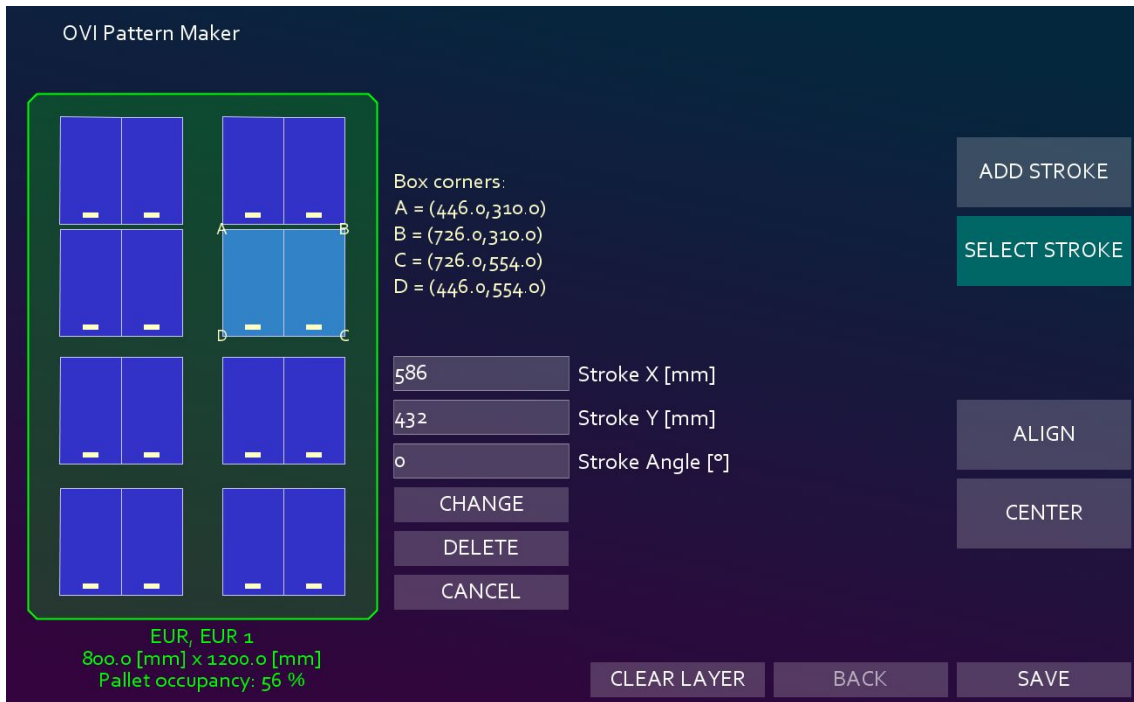

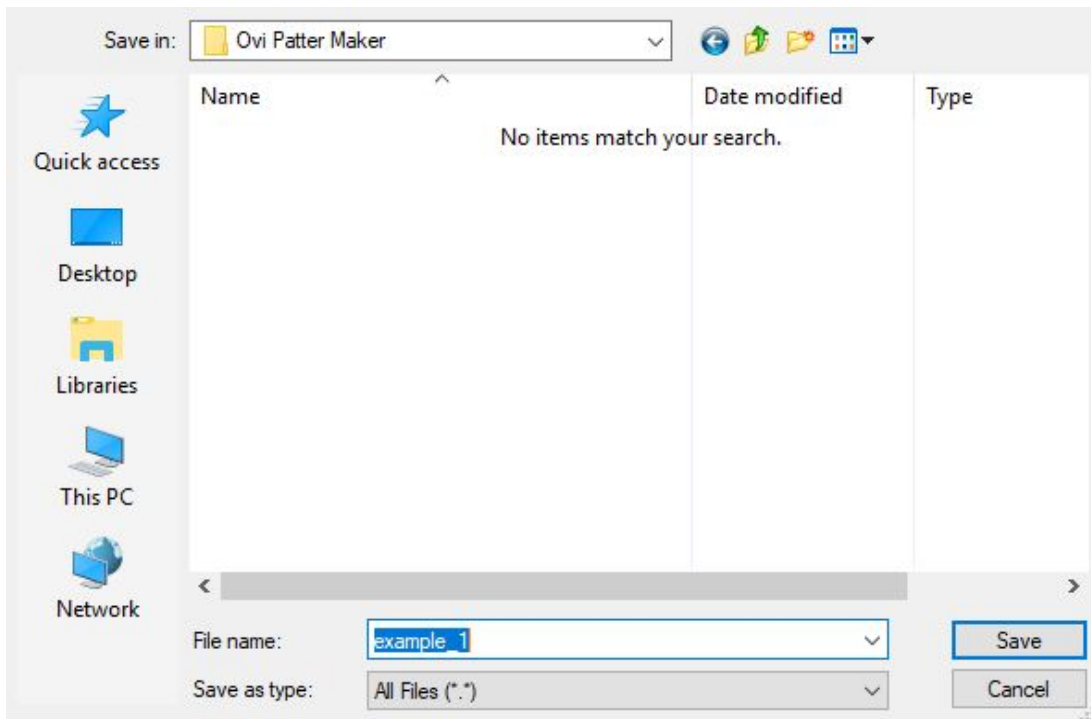

**Step 8:** When everything is ready, just press “SAVE”. A window will appear prompting for a name and a location where the generated files will be saved.



**Step 9:** Click “Save” and the Ovi Pattern Maker will generate 2 files:

- a. A PDF file containing information about the pattern;
- b. An XML file with relevant pattern data which should be transferred to the robot and uploaded to the Ovi Palletiser URCap.

Name	Date modified	Type
 example_1	10/10/2019 11:00 ...	Adobe Acrobat D...
 example_1	10/10/2019 11:00 ...	XML Document